



## **Bid Documents for**

**DESIGN AND CONSTRUCTION OF TRAIN PROTECTION & WARNING SYSTEM (TPWS)  
FOR REWARI – JNPT SECTION (Combined for Phase 1 and Phase 2) INCLUDING  
TESTING AND COMMISSIONING ON DESIGN-BUILD LUMP SUM PRICE BASIS OF  
WESTERN DEDICATED FREIGHT CORRIDOR**

**TRAIN PROTECTION AND WARNING SYSTEM WORKS CONTRACT  
Rewari – Makarpura of Phase 1 and Makarpura - JNPT of Phase 2**

**CONTRACT PACKAGE ST P-5A**

**VOLUME-III  
EMPLOYER'S REQUIREMENTS  
Particular Specifications**

Employer:

**DEDICATED FREIGHT CORRIDOR CORPORATION OF INDIA LIMITED  
(A GOVERNMENT OF INDIA ENTERPRISE)**

**MINISTRY OF RAILWAYS  
INDIA**

## TABLE OF CONTENTS

### Chapter Page

1.	SCOPE OF WORKS .....	1
1.1	General .....	1
1.2	Relevant Documents .....	1
1.3	Employer’s Requirements .....	1
1.4	System Overview .....	3
1.5	Infringement of patent Rights.....	4
2.	DEFINITIONS AND ABBREVIATIONS.....	5
2.1	Definitions .....	5
2.2	Abbreviations.....	5
3.	DESIGN CRITERIA AND STANDARD .....	9
3.1	Basic Design Philosophy and Requirements .....	9
3.2	Design Criteria.....	10
3.3	Design Standard.....	10
3.4	System Assurance .....	11
3.5	RAMS DEMONSTRATION.....	12
4.	ENGINEERING CONDITIONS .....	14
4.1	Engineering Philosophy.....	14
4.2	Safety Requirements.....	14
4.3	Reliability Requirements.....	14
4.4	Maintenance Requirements.....	15
4.5	Electromagnetic Compatibility (EMC) Requirements .....	15
4.6	Painting Requirements .....	15
5.	FUNCTIONAL REQUIREMENTS .....	16
5.1	General .....	16
5.2	Equipment Response Time .....	16
5.3	Train Protection &Warning System (TPWS) .....	16
5.4	Train Detection system.....	20
5.5	Electronic Interlocking System (To be provided by P5 & P17 Contractors) .....	20
5.6	Stations .....	21
5.7	Block sections .....	21
5.8	Level Crossing gates.....	22
5.8.1	All level crossing gates shall be interlocked with signals by P5 & P17 Contractors keeping the following in view: .....	22
5.9	Train Monitoring and Diagnostic System (TMS).....	22

5.10	Power Supply System (PSS) (To be provided by P5/P17 Contractors).....	22
5.11	Bonding Design.....	24
5.12	Signage.....	24
6.	SYSTEM REQUIREMENTS.....	25
7.	TECHNICAL REQUIREMENTS.....	26
7.1	Fail Safe Technology.....	26
7.2	Foolproof Technology.....	26
7.3	Processing Time.....	26
7.4	Ergonomic Technology.....	26
7.5	Redundancy Technology.....	26
8.	<b>CONTRACTOR’S COORDINATION WITH OTHERS (INTERFACE MANAGEMENT)</b> .....	28
8.1.	General.....	28
8.2.	Contractor’s Responsibility.....	28
8.3.	Physical Interface with Other Contractors, Interfacing Parties, relevant authorities and agencies.....	28
8.4.	General Definitions and Scope.....	28
8.5.	Contractors’ Responsibilities.....	29
8.6.	Physical interface issues – General.....	30
8.7.	ELECTRICAL & PHYSICAL INTERFACE.....	31
8.8.	Earthing & Bonding.....	31
8.9.	ANTI THEFT CHARGING OF OHE.....	32
8.10.	Systems Integration Requirements.....	33
9.	TESTING, COMMISSIONING AND VERIFICATION.....	35
9.1	General.....	35
9.2	Test Plan and Procedures.....	35
9.3	Costs of Tests.....	36
9.4	Records of Tests.....	36
9.5	Sources of equipment supply.....	37
9.6	Type Tests.....	37
9.7	Types of tests.....	38
10.	INSTALLATION.....	42
10.1	General.....	42
10.2	Installation Programme.....	42
10.3	Installation Works.....	43
10.4	Cabling.....	46
10.5	Marshalling and Termination.....	48
10.6	Labelling.....	49

10.7	Earthing.....	49
10.8	Lightning and surge protection .....	52
10.9	Housing, Enclosure and Cabinet .....	53
11.	PACKAGING, SHIPPING, STORAGE AND DELIVERY .....	55
11.1	Packaging .....	55
11.2	Storage.....	55
11.3	Delivery .....	56
12.	DOCUMENTATION.....	57
12.1	General .....	57
12.2	List of Drawings.....	57
12.3	Submission requirements .....	58
12.4	Levels of submission .....	59
12.5	As-built documentation .....	60
13.	OPERATION AND MAINTENANCE SUPPORT .....	61
13.1	General .....	61
13.2	Operation and Maintenance Document .....	61
13.3	Operation and Maintenance Plan .....	61
13.4	Software Support.....	62
13.5	Support during Defects Liability Period.....	62
13.6	Spares, Special Tools, Diagnostic equipment and Test Equipment .....	64
14.	TRAINING .....	67
14.1	General .....	67
14.2	Scope of Training .....	67
14.3	General Requirements .....	67
14.4	Training Plan .....	68
14.5	Training Courses.....	69
14.6	Operating Staff Courses .....	69
14.7	Maintenance Staff Courses .....	70
14.8	Training Materials.....	72
14.9	Training Records.....	72
14.10	Course Evaluation.....	72
<b>Annexure 1: Train Monitoring &amp; Diagnostic System – Functional Requirement Specification1</b>		
1.	SCOPE.....	1
2.	TMS SYSTEM ARCHITECTURE .....	1
3.	SYSTEM RESPONSE TIME .....	1
4.	AGGREGATION OF INFORMATION .....	1
5.	LIVE INDICATIONS.....	2

6.	TRAIN DESCRIBER SYSTEM .....	5
7.	MANAGEMENT INFORMATION SYSTEM .....	7
8.	TRAIN GRAPH REQUIREMENTS FOR TIME TABLE SYSTEM .....	10
9.	LOG AND ALARM SYSTEM .....	11
10.	SOFTWARE DETAILS .....	12
11.	INTEGRATION WITH TRAIN RADIO COMMUNICATION SYSTEM .....	13
	Annexure 2: Train Monitoring & Diagnostic System – Technical Specification .....	1
1.	INTRODUCTION.....	1
2.	FUNCTIONAL REQUIREMENT SPECIFICATION (FRS).....	1
3.	GENERAL DESCRIPTION .....	1
4.	SYSTEM DESIGN SPECIFICATION .....	2
5.	SYSTEM (TECHNICAL) REQUIREMENT SPECIFICATION .....	8
6.	CONTROL OFFICE EQUIPMENT .....	8
7.	DUAL LAN SYSTEM .....	19
8.	VIDEO WALL DISPLAY SYSTEM .....	21
9.	POWER SUPPLY ARRANGEMENT .....	28
10.	WAYSIDE STATION EQUIPMENT .....	28
11.	SOFTWARE .....	33
12.	INTEGRATION WITH GSM(R) BASED MOBILE TRAIN RADIO SYSTEM .....	41
13.	SPARES.....	41
14.	DOCUMENTATION.....	42
15.	TRAINING & TRAINING DOCUMENTS/GADGETS .....	42
	Annexure 3: List of Junction and Crossing Stations .....	1
	Annexure 4: Typical Signalling Plan of Depot.....	1
	<b>(Note: Attached separately)</b> .....	1
	ANNEXURE 5: CHAPTER XIV OF IRSEM - SAFETY DEVICES TO BE PROVIDED AT L.C. GATES.....	1
	ANNEXURE 6: POLICY OF TRAIN OPERATION PLANNING ON WDFC .....	1
	ANNEXURE 7-1: PHYSICAL INTERFACE BETWEEN EM P-4 / EM P-16 & ST P-5A – SPECIFIC ISSUES .....	1
	ANNEXURE 7-2: PHYSICAL INTERFACE BETWEEN RS P-7 & ST P-5A: SPECIFIC ISSUES1	
	ANNEXURE 7-3: PHYSICAL INTERFACE ISSUES BETWEEN ST P-5A & Civil works contractors .....	1
	ANNEXURE 7-4: NOT USED .....	1
	ANNEXURE 7-5: NOT USED .....	1
	ANNEXURE 7-6: INTERFACE ISSUES BETWEEN ST P-5, ST P-17 AND ST P-5A .....	1
	ANNEXURE 8: SPECIFICATIONS OF PRE-FABRICATED AUTO LOCATION HUTS.....	1
	ANNEXURE 9: GUIDELINES ON SIGNALLING CABLE LAYING .....	1
	ANNEXURE 10: SAFETY, HEALTH AND ENVIRONMENTAL (SHE) REQUIREMENTS .....	1

Annexure 11: DFCCIL’s procedure for Cross Acceptance .....1  
Annexure 12: Cross acceptance responsibility matrix .....1

## 1. SCOPE OF WORKS

### 1.1 General

- 1.1.1 The main purpose of Signalling is to secure the safety of train operation in all the lines and to realize the efficient traffic in order to provide an undisturbed transportation service to the public.
- 1.1.2 The Contract shall comprise design, supply, factory testing, installation, integration with other contracts, site testing, commissioning, training and defects liability of the Train Protection and Warning system.
- 1.1.3 All Main Signals at stations, Block sections, and Level Crossing gates shall be equipped with TPWS system. Signalling system in Depot shall be provided by P-7 contractor. However, TPWS on Test Track as well as on entry and exit signals in depot shall be provided by ST P-5A Contractor.
- 1.1.4 The Contractor shall ensure interoperability between TPWS system of DFCCIL with that of IR.

### 1.2 Relevant Documents

- 1.2.1 This Particular Specification (PS) shall be read in conjunction with the General Conditions of Contract (GCC), the General Specification (GS), and any other document forming part of the Contract.
- 1.2.2 In the event of a conflict between the GS and the PS, the requirements of the PS shall prevail.
- 1.2.3 In the event of a conflict between this Particular Specification and any other standards or specification quoted herein, the requirements of this Specification shall prevail. The order of precedence, with item a) having the highest priority, is:
  - a) Employer's Requirements - Particular Specification
  - b) Employer's Requirements - General Specification
  - c) Indian Standards
  - d) International Standards referenced herein.
  - e) Other International Standards
  - f) Other National Standards.
- 1.2.4 Notwithstanding the precedence specified, the Contractor shall always immediately seek advice from the Engineer in the event of any conflict between above items.
- 1.2.5 The contents on these standards shall be considered along with its latest amendments as on base date.
- 1.2.6 Notwithstanding the contents of Sections 1.2.1 and 1.2.2 above, the Contractor shall always immediately seek advice from the Engineer in the event of any conflict between specifications

### 1.3 Employer's Requirements

- 1.3.1** The TPWS system shall be constructed to conform to the Employer's Requirements and other internationally recognized standards and shall be designed for secured system.
- 1.3.2** The Contractor shall coordinate with civil infrastructure Contractors (Package 1, 2, 3, 3A, 7, 11, 12, 13, 15A & 15B) for detailed interface requirements on the railway route alignment and main line track layout in accordance with Employer's Requirements and other design criteria. He shall also coordinate with other Contractors (Package 4, 5, 16 & 17) as required.
- 1.3.3** The Contractor shall design the TPWS based on the system operation and maintenance plan, IEC and / or equivalent international standards specification. These will be as described in General Specification of Package 5A.
- 1.3.4** The redundant data transmission system with ring configuration working on Optical Fiber Network shall be utilized for communication between stations including Auto Location Huts and OCC.
- 1.3.5** All the functions on the data transmission shall be protected against unauthorized operation by the Area Of Responsibility (AOR) mechanism.
- 1.3.6** NOT USED
- 1.3.7** The Service Life for the TPWS shall be more than twenty (20) years with the need for refurbishment running not less than ten (10) years into this period.

**1.3.8**

Connections to IR & Sidings:

- (a) The tracks connecting DFCCIL Junction stations with IR stations shall be provided with Absolute Block Signalling with block/ slot working. Where such track lengths are less than 4 Kms., any of block/ slot working may be adopted. For longer track lengths, Absolute Block working using Block Proving by Axle Counter using UFSBI as per RDSO specification No. IRS: S 105 shall be provided.
- (b) Wherever sidings connected to IR stations shall get the connection transferred to DFCCIL stations, existing system of Block/ Slot working shall be transferred from IR station to DFCCIL station.
- (c) Details of Connections to IR & Sidings are given in Vol. V of Bid Documents.

- 1.3.9** Manufacturer and provenness details of all locally procured major TPWS equipment (if not appearing in RDSO's approved list of vendors) shall be submitted as part of Bid offer.

**1.3.10** Cross Acceptance of major imported TPWS Equipment:

- (a) Manufacturer & provenness details and Cross Acceptance approval (by RDSO/DFCCIL) status of all major imported TPWS equipment shall be submitted in Form I-B-9, Volume I Part ½ of Bid documents.
- (b) If any such equipment is not yet having Cross Acceptance approval, the Contractor shall get the same done as per RDSO/ DFCCIL's Cross Acceptance Procedure. DFCCIL's Cross Acceptance Procedure is kept as Annexure 11 in Vol. III of Bid Documents.



(c) The Contractor shall be responsible for timely action on all items related to Cross Acceptance so that approval is available well in time to achieve Contract Milestone MS-1. Some of these, but not limited to, are as under:

(i) Submission of Safety Case & other documents to ISA with copy to the Employer & the Engineer.

(ii) Submission of type test plan.

(iii) Conduct of type tests.

(iv) Submission of type test report.

(v) All items related to field trial including Submission of report.”

(d) Responsibility Matrix for Cross Acceptance Procedure kept as Annexure 12 in Vol. III of Bid Documents shall be followed.

**1.3.11** The Contractor shall prepare a plan that shall identify in detail the sequence of testing that shall include as a minimum the evaluation of prototypes at the Contractor's factory and testing of prototype equipment in the normal sequence of factory and on-site testing for production of equipment.

**1.3.12** The Contractor shall prepare a plan in accordance with the Employer's Requirements that shall be presented for the Engineer's review and shall as a minimum describe the content, duration, timing and location of all training activities proposed by the Contractor.

**1.3.13** The Contractor shall prepare and supply all necessary training documentation and operating and maintenance manuals for the review of the Engineer.

**1.3.14** The Contractor shall be responsible for integration of TPWS with other Signalling System (being provided by other Contractors), through suitable interface and coordination.

## **1.4 System Overview**

**1.4.1** The TPWS system shall consist of necessary sub-systems or equipment as required. In accordance with the requirement, the Contractor shall propose appropriate system configuration with sub-system or equipment for review by the Engineer.

### **1.4.2 NOT USED**

### **1.4.3 OCC:**

1.4.3.1 The trains on main and running lines and Depot access line shall be all supervised in OCC. All routes setting shall be carried out at local stations. All necessary data shall be collected in OCC. Refer Annexure 1 and Annexure 2 for FRS and Technical specs of TMS respectively. TMS shall be provided by P-5 & P-17 Contractors.

### **1.4.4 Depot:**

a) Signalling inside the Depot shall be provided by P-7 contractor. However, ST P-5A contractor shall provide TPWS on Test Track as well as on entry and exit signals in the Depot. In addition, P-5 contractor shall provide

Signalling Monitor console in TPWS maintenance room in the Depot linking it to console of Signal Fault Controller in OCC.

- b) Typical Signalling Plan of Depot may be referred at Annexure 4. It may be noted that Trap and Point taking off from main line and Crossover between UP and DN lines of DFCCIL at Dadri end of Depot shall be controlled from DFCCIL's Rewari Interlocking.

#### **1.4.5 Crew Lobbies & Signal Maintenance Base:**

1.4.5.1 Maintenance Base will be in designated IMDs. Similarly there will be designated Crew Lobbies for booking of drivers.

1.4.5.2 Necessary equipment shall be provided in Signal Maintenance Bases.

### **1.5 Infringement of patent Rights**

The Employer shall not be responsible for infringement of patent rights arising due to similarity in design, manufacturing process, use of similar components in the design and development of the TPWS and any other factor not mentioned herein which may cause such a dispute. The entire responsibility to settle any such disputes/matters shall lie with the Contractor.

\* \* \* End of Chapter 1 \* \* \*

## 2. DEFINITIONS AND ABBREVIATIONS

### 2.1 Definitions

In this Particular Specification, the following defined terms shall have the meanings described below:

Definitions	Descriptions
Probability	The probability that an item will be in a state to perform a required function under given conditions, at a given instant in time or over a time interval, assuming that the given external resources are provided.
Design Life	The design life of the TPWS System is the period of time during which the item is expected to work within its specified parameters; in other words, the life expectancy of the system.
Main Line	The DFCCIL line between JNPT and Rewari station.
Access line	The line between Main Line and Depot entrance.
Depot	All the area for Electric Loco Maintenance including stabling tracks, shunting tracks, work station, test track, inspection track, Loco washing track, wheel re-profiling track and maintenance berths from Depot entrance to these tracks.
TPWS System	Each system comprising Train Protection and Warning System.
Train Number	Alphanumeric number uniquely identifying a running train.
MMI	MMI device with video display, keyboard and mouse for Traffic Controller and Assistant station Master.
Control panel or Video wall	A graphical representation of the railway and its global operating status.

### 2.2 Abbreviations

Abbreviations used in this Particular Specification are as listed below:

ACTM	Alternating Current Traction Manual
ARO	Area Of Authority
ARS	Automatic Route Setting
ASCII	American Standard Code for Information Interchange
ASM	Assistant Station Master
ATS	Automatic Transfer Switch
BCC	Backup Control Centre
CD	Compact Disc
CENELEC	European Committee for Electrotechnical Standards (Comite Europeen de Normalisation Electrotechnique)

CHC	Chief Controller
CITT	International Telegraph and Telephone Consultative Committee
CKD	Completely Knocked down
CMS	Crew Management System
CTC	Centralised Traffic Control
CTR	Cable Termination Rack
CV	Curriculum Vitae
DAC	Digital Axle Counter
DAT	Digital Audio Tape
DBMS	Data Base Management System
DCC	Depot Control Centre
DLP	Defect Liability Period
DLP	Digital Light Processing
DMI	Driver Machine Interface
DSS	Decision Support System
DTS	Data Transmission System
DyCHC	Deputy Chief controller
EI	Electronic Interlocking
ELMD	Electric Loco Maintenance Depot
EMC	Electro Magnetic Compatibility
EMI	Electro Magnetic Interference
EPROM	Erasable Programmable Memory
ETCS	European Train Control System
FAT	Factory Acceptance Tests
FIU	Field Interface Unit
FRACAS	Failure Reporting and Corrective Action System
FRS	Functional Requirement Specification
G & SR	General and Subsidiary Rules
GCC	General Conditions of Contract
GPS	Global Positioning System
GS	General Specification
GSM(R)	Global System for Mobile communication (Railway)
HDD	Hard Disk Drive
HDPE	High Density Poly Ethylene
I/O	Input Output
IC	Integrated Circuit
ID	Identification
IEC	International Electro-technical Commission
IEEE	Institute of Electrical and Electronic Engineering
IGBT	Insulated Gate Bipolar Transistor
IMD	Integrated Maintenance Depot
IPMI	Intelligent Platform Management Interface
IR	Indian Railways
IRJ	Insulated Rail Joint
IRPWM	Indian Railways Permanent Way Manual
IRSEM	Indian Railways Signal Engineering Manual
ISA	Independent Safety Assessor
ISO	International Standards Organization
ITU	International Telecommunications Union
JE	Junior Engineer
JIS	Japanese Industrial Standard

JNPT	JawaharLal Nehru Port Trust
LAN	Local Area Network
LBS	Local Bus Synchronisation
LC	Level Crossing
LCD	Liquid Cristal Display
LED	Light Emitting Diode
LEU	Lineside Electronic Unit
MIS	Management Information System
MLIT	Ministry of Land, Infrastructure, Transport and Tourism
MMI	Man Machine Interface
MSDAC	Multi Section Digital Axle Counter
MTBF	Mean Time Between Failure
MTBMA	Mean Time Between Maintenance Action
MTRC	Mobile Train Radio Communication
NDA	Non Described Alarm
NMS	Network Management System
O&M	Operation and Maintenance
OBC	On Board Computer
OCC	Operation Control Centre
OEM	Original Equipment Manufacturer
OFC	Optical Fibre Cable
OHE	Over Head Equipment
ORP	Overrun Protection
PC	Personal Computer
PLC	Programmable Logic Controller
PS	Particular Specification
PSS	Power Supply System
PTR	Proven Track Record
PVC	Poly Vinyl Chloride
RAID	Redundant Array of Independent Discs
RAM	Random Access Memory
RAMS	Reliability, Availability, Maintainability and Safety
RDSO	Research, Design & Standards Organisation
RE	Railway Electrification
SATA	Serial Advanced Technology Attachment
SCADA	Supervisory Control And Data Acquisition
SCOR	Section Controller
SCR	Silicon Controlled Rectifier
SCSI	Small Computer System Interface
SE	Sectional Engineer
SER	Signal Equipment Room
SKD	Semi Knocked Down
SNMP	Simple Network Management Protocol
SOD	Schedule of Dimensions
SQL	Structured Query Language
TBD	To Be Decided
TC	Traffic Controller
TCP/IP	Transfer Control Protocol / Internet Protocol
TD	Train Detection
TDS	Train Describer System
TMS	Train Monitoring and Diagnostic System
TPC	Traction Power Controller

TOT	Transfer Of Technology
TPWS	Train Protection & warning System
TSR	Temporary Speed Restriction
TVSS	Transient Voltage Surge Suppressor
UART	Universal Asynchronous Receiver/Transmitter
UIC	International Union of Railways
UXGA	Ultra eXtended Graphic Array
VDU	Visual Display Unit

\* \* \* End of Chapter 2\* \* \*

### 3. DESIGN CRITERIA AND STANDARD

#### 3.1 Basic Design Philosophy and Requirements

##### 3.1.1 Proven Design

- (a) The Contractor shall develop the design based on this Technical Specification. The design details shall be submitted with technical data and calculations to the Engineer for approval.
- (b) Train Protection and Warning System including all sub-systems and equipment shall be of proven design. The system/sub-system, equipment, hardware and software proposed by the Contractor shall have been in use and have established their satisfactory performance over a period of at least two years on the worldwide railway/metro/monorail systems during last five years.
- (c) Where similar equipment or sub-systems of a different rating are already proven in service, then the design shall be based on such equipment.
- (d) In case stipulations (a) and (b) are not fulfilled, the Contractor shall furnish sufficient information to prove the basic soundness and reliability of the offered Sub-system to the satisfaction of the Engineer.

##### 3.1.2 The design philosophy shall meet the following criteria:

- (i) Application of state-of-the-art Technology;
- (ii) Service proven design;
- (iii) NOT USED;
- (iv) Minimum life cycle cost;
- (v) Ease of maintainability;
- (vi) Use of interchangeable, modular components;
- (vii) Extensive and prominent labelling of parts, cables and wires;
- (viii) Use of unique serial numbers for traceability of components;
- (ix) High reliability;
- (x) Energy efficiency;
- (xi) System safety;
- (xii) Adequate redundancy and factor of safety;
- (xiii) Use of fire retardant materials for On board equipment wiring;
- (xiv) Environment friendly;
- (xv) Adherence to functional, operational and performance requirements;
- (xvi) Open Architecture for integration with other Systems and
- (xvii) Ease of expansion and integration.

3.1.3 Adequate margin shall be built into the design particularly to take care of the environmental considerations prevailing in Delhi, Haryana, Rajasthan, Gujarat and Maharashtra.

3.1.4 The CV's of the key design personnel shall be provided to the Engineer for prior approval.

### 3.2 Design Criteria

3.2.1 TPWS system shall be on board intelligence system and the communication between train and ground for this purpose shall be through Balise. 200 Locos shall be required to be provided with ON-Board TPWS.

3.2.2 LEUs shall preferably be provided indoor i.e. in Signal equipment Rooms at stations and in Auto Location Huts in Block sections. However, LEUs may be provided track side if required by design subject to consent by the Engineer at Detailed Design Stage.

3.2.3 The TPWS system shall satisfy the requirement of train operation described in Annexure 6 containing Policy of Train Operation Planning.

3.2.4 Please refer Data Book Vol. IV of Bid Documents for list of interlocked Level Crossing gates.

3.2.5 Automatic Signalling shall be provided by other Contractor with nominal signal spacing of 2 Kms.

### 3.3 Design Standard

3.3.1 For the TPWS, the generic standards or other equivalent standards and standards which are specified in following shall be applied.

- a) RDSO, Research, Design and Standards Organization, Ministry of Railways, India.
- b) IEC: International Electro-technical Commission
- c) ISO: International Standards Organization
- d) JIS: Japanese Industrial Standard
- e) JEITA: Japan Electronics and Information Technology Industry Association

3.3.2 For the TPWS system, standards as given below, but not limited to, shall be followed.

S.No.	Standard	Description
1	EEIG: 97s066	ERTMS/ETCS Environmental requirements
2	IEC 60364	Electrical Installations for Buildings
3	IEC 60571	Electronic Equipment Used on Rail Vehicles
4	IEC 61373	Railway Applications – Rolling stock equipment – Shock and vibration tests
5	IEC 61992	Railway applications – Surge arresters and low-voltage limiters for specific use in d.c. systems
6	IEC 62236	Railway Applications – Electromagnetic compatibility (EMC)



7	IEC 62278	Railway Applications- Specifications and demonstration of Reliability, Availability, Maintainability & Safety.
8	IEC 62279	Railway Applications-Communications, Signalling and processing systems-Software for Railway Control and Protection Systems.
9	IEC 62280-1	Railway Applications-Communications, Signalling and processing systems - Safety related communication in closed transmission systems.
10	IEC 62280-2	Railway Applications-Communications, Signalling and processing systems - Safety related communication in open transmission systems.
11	IEC 62305	Protection against Lightning
12	IEC 62425	Railway Applications-Communications, Signalling and processing systems- Safety Related Electronics Systems for Signalling.
13	IEC 62427	Railway Applications- Compatibility between Rolling Stock and Train Detection Systems
14	IEC 62505	Railway applications – Fixed installations – Particular requirements for a.c. switchgear
15	IRS: S 21	Electric Key Transmitter
16	IRS: S 23	Electrical and Electronic based Signalling and Interlocking Equipment
17	IRS: S 34	Testing Railway Signaling Relays (General)
18	IRS: S 63	PVC insulated underground unscreened Signalling Cables for Railway Signalling
19	IRS: S 76	PVC insulated indoor Cables for Railway Signalling
20	IRS: S 93(A)	Secondary Cell – Maintenance Free
21	IRS: S 99	Data Logger
22	IRS: TC30	Underground Railway Jelly Filled Quad Cables for Signaling and Telecom Installations
23	RDSO/SPN/144	Safety and reliability requirement of electronic signalling equipment.
24	RDSO/SPN/183	Train Protection & warning System
25	RDSO/SPN/189	Terminal Blocks, Fuse Terminal Blocks and Miniature Fuse Links of International Standard
26	RDSO/SPN/197	Code of practice for earthing and bonding system for Signalling equipment
27	RDSO/SPN/256	Earth Leakage detector

3.3.3 Following manuals shall be referred as required:

- a) Indian Railways Signal Engineering Manual (IRSEM)
- b) General and Subsidiary Rules (G&SR) of DFCCIL
- c) AC Traction Manual (ACTM) of IR
- d) Indian Railways Permanent Way Manual (IRPWM)
- e) Schedule of Dimensions (SOD) of DFCCIL

### 3.4 System Assurance

- 3.4.1 The Contractor shall carry out system assurance to ensure that the requirements for safety, reliability, availability and maintainability for the TPWS are met.
- 3.4.2 System assurance activities shall include RAMS activities and the preparation of all supporting documentation. System assurance activities shall comply with the requirement in accordance with IEC 62278 Railway applications – Specification and demonstration of reliability, availability, maintainability and safety (RAMS).
- 3.4.3 System RAMS plan and its associated RAMS analysis work shall be undertaken at system level to demonstrate that the reliability, availability, maintainability and safety requirements are met.
- 3.4.4 The Contractor shall submit a RAMS report including result of internal audit by Contractor's organization or certification by third party verifier.
- 3.4.5 The Employer shall employ third party Independent Safety Assessor(s) (ISA) for Safety Assessment of certain imported signalling/ TPWS equipment as per Cross Acceptance Procedure of DFCCIL and also certification of complete signalling system including TPWS as per SIL requirements. The Contractor shall provide necessary documents and assistance to facilitate ISA's work.
- 3.4.6 The Contractor shall submit the report that the safety of TPWS meets SIL4 in IEC 62279 or equivalent safety level.

### **3.5 RAMS DEMONSTRATION**

- 3.5.1 The P5 Contractor shall establish a Failure Reporting and Corrective Action System (FRACAS) to demonstrate compliance with specified system and equipment reliability. It shall be a database system containing fields similar (but not limited to) "Signal failure Register" and facility to generate Management Reports as per requirement of Engineer/Employer. The P5A Contractor shall provide TPWS inputs to this system and supplement the same with hardware/ software, if required, and use it for similar purpose in coordination with P5 Contractor.
- 3.5.2 The Contractor shall collect and maintain data on every Service Affecting Failure along with the data indicating the probable failure. The Contractor shall submit monthly RAM Demonstration Reports based on service failure data.
- 3.5.3 The failure of TPWS is defined as the failure of which cause is related to design, manufacture and/or installation of the Contractor except Operation and Maintenance.
- 3.5.4 The Contractor shall submit reliability calculations to confirm that the TPWS meets reliability requirements.
- 3.5.5 In case the Contractor is not able to achieve the specified/provided RAMS targets, the Contractor shall take necessary corrective measures either by way of change of design of the relevant equipment/component, software modification or change in maintenance regime at no additional cost to the Employer.
- 3.5.6 The Contractor shall analyse each and every failure/defect of components of various equipment to determine the cause of failure and to propose corrective measures. All these details shall be summarized in the investigation reports for Engineer's review and approval. The approved failure reports shall be retained as traceable record and maintained by using the computer based FRACAS.

3.5.7 The Contractor will be evaluated for RAMS demonstration during Defect Liability Period except initial 3 months beginning from revenue operation.

\* \* \* End of Chapter 3 \* \* \*

## 4. ENGINEERING CONDITIONS

### 4.1 Engineering Philosophy

The safety, the reliability and the maintainability required in TPWS shall consider the contents in IEC 62278 (RAMS) and IEC 62425 but need not to be constrained (it means including report of Independent Safety Assessor independent of contractor's design section as stated in chapter 3).

### 4.2 Safety Requirements

- 4.2.1 Concerning the safety of TPWS system, IEC 62425 shall be referred but need not be constrained by it.
- 4.2.2 The safety level of TPWS shall satisfy the SIL4 or equivalent safety level.
- 4.2.3 The documents of safety principles related with TPWS shall be submitted to the Engineer.
- 4.2.4 Even when long power failure results in total drainage of PSS / LEU batteries, the line side equipment of TPWS shall be ready after Power-ON and initialization for use within two minutes of power restoration.
- 4.2.5 The Contractor shall show expected calculated failure rate related to TPWS and show safe failures and hazard failures separately.
- 4.2.6 Accompanied to the documents, internal audit by Contractor's organization or audit by third party specialist shall be required.

### 4.3 Reliability Requirements

- 4.3.1 If failure of any sub-system is likely to adversely affect the train operation, the reliability shall be enhanced by providing redundancy in the equipment.
- 4.3.2 Duplicated system shall change uninterrupted when one system fails. If duplicated system has changing time, contractor shall show that its system shall not obstruct the train operation.
- 4.3.3 The Contractor shall submit calculation sheets in respect of all the sub-systems in the TPWS.
- 4.3.4 The TPWS line side equipment shall be engineered for a minimum Service Life of 20 years, based on the equipment being continuously in operation, and shall achieve an MTBSAF (Mean Time Between Service Affecting Failures) of no less than 1000 hours between any failures affecting the revenue train service.
- 4.3.5 The indoor Electronic Equipment in Stations and Block sections shall be engineered for a minimum Service Life of 20 years, based on the equipment being continuously in operation, and shall achieve an MTBF of not less than 7 days for entire Rewari – JNPT section.
- 4.3.6 NOT USED

- 4.3.7 Trackside equipment, Location boxes, etc. shall be designed and fixed with anti-theft measures.

#### **4.4 Maintenance Requirements**

- 4.4.1 Fundamentally, the system shall be designed based on the maintenance free concept.
- 4.4.2 The Contractor shall provide built-in diagnostics and remote monitoring functions for each equipment and module of the systems such that the performance can be demonstrated.
- 4.4.3 Monitoring system shall be so provided in order to support maintenance staff by suitable alarm generation message for predictive failure and if failure occurs, then they can locate the failure point with the data, transmitting/receiving signal levels recorded, operation record etc.
- 4.4.4 Each Location Box and other such standalone track side box shall be provided with its independent light to attend to failures during night time.

#### **4.5 Electromagnetic Compatibility (EMC) Requirements**

- 4.5.1 The Contractor shall investigate the electromagnetic compatibility together with Rolling stock contractor regarding TPWS after the installation of this system. Proximity to IR's 25KV RE and its effect on DFC equipment shall also be taken into account.
- 4.5.2 Above referred electromagnetic compatibility investigation shall be carried out referring IEC62236 but need not to be constrained by it.
- 4.5.3 The Contractor shall measure the signal level and noise level in the site especially near the substation. Both P-5A and P-7 contractors shall confirm the electromagnetic compatibility based on the measured data.
- 4.5.4 The Contractors shall submit the confirmation with data to the Engineer for review after the site testing.

#### **4.6 Painting Requirements**

- 4.6.1 All TPWS gears shall be painted and numbered as per provisions given in Signal Engineering Manual.
- 4.6.2 Clearances of individual track side gears from nearest rail shall be painted on the gear itself. Sample for the same shall be got agreed by the Engineer.

\* \* \* End of Chapter 4 \* \* \*

## 5. FUNCTIONAL REQUIREMENTS

### 5.1 General

- 1) The TPWS equipment shall immediately report certain functions, typically, but not limited to the following:
  - a) TPWS System failures (Input to be provided by ST P-5A Contractor to ST P-5/ ST P-17 Contractors);
  - b) Power supply failures including Power supply equipment defects and earth faults;
- 2) All alarms shall clearly indicate the nature and the location of the cause. Loco Pilots, ASMs and OCC staff shall have manual facilities to acknowledge (and thus cancel) each alarm individually.

### 5.2 Equipment Response Time

- 1) Equipment response times for all On board and line side equipment shall be inclusive of all processing time and display time.
- 2) Response time in this context is time taken for the equipment to process the commands (or input) and generate a signal at the output (MMI).
- 3) All commands initiated by Loco Pilots shall generate an immediate change in the display to indicate that the command has been received and this change shall be such that pending commands are distinguishable from completed commands so as not to induce any ambiguous recognition on the part of the Loco Pilots and potential unsafe operation.

### 5.3 Train Protection & Warning System (TPWS)

#### 5.3.1 General

- 1) TPWS shall be provided as per RDSO specification.
- 2) General information about TPWS requirements are as under:

a)	Type of locomotives and their brake system on which the TPWS is to be installed.	To be decided in interface.
b)	Brake interface in terms of clause 5.13.1.	To be decided in Interface.
c)	Type of signals where TPWS is to be installed.	All main signals in station areas, block sections, Test Track and exit/entry signals of ELMD.
d)	Available braking distance in the section.	To be advised at design stage.

e)	The voltage of input power supply available for On board and track side system.	On-board: To be decided in Interface. Track side: P5A contractor may propose.
f)	The duration of battery backup required for LEU, if required for more than half an hour.	Only half an hour (Required only for LEUs provided on Track side).
g)	Relevant G & SR rules applicable alongwith speed restriction limits.	To be advised at design stage.
h)	Class of balise in terms of clause 6.21.	Class "A"
i)	Period of Warranty, if required for more than one year.	Three years after expiry of Defect Liability Period.
j)- (i)	The number of inputs & number of output channels for which different LEUs to be equipped in terms of Cl. 6.20.	P5A Contractor to advise for decision at design stage.
j)- (ii)	The length & number of pairs of the balise controlling interface cable as per requirement & site conditions in terms of Cl. 6.20.	(a) P5A Contractor shall advise maximum workable length of cable. (b) This cable shall have only one pair without any spare core.
k)	Purchaser shall specify the details of section, signalling details, type of locomotive and brake system to be used in the section in terms of clause 4.5 to 4.10.	Primarily to work on DFC.
l)	Details mentioning the UIC/UNISIG SRS/FRS version of existing TPWS system with which the TPWS as per this specification is required to be interoperable.	Ver. 2.3.0.d
m)	Requirement of Juridical Recording Unit (JRU) in terms of Clause 4.1 (ii) (b).	Not required.
n)	After award of contract, following information shall also be provided by the purchaser:	-
n)- (i)	Availability of potential free contact of lamp proving relays.	P5A Contractor to interface with P-5 & P-17 Contractors for its availability.
n)- (ii)	Details of the section like gradients, permanent speed restrictions, maximum sectional speed and route details of the section etc. where TPWS is to be installed.	To interface with package 1,2,3, 11, 12 & 13 Contractors.
n)- (iii)	Location of Signals.	P5/P17 Contractor to design.
n)- (iv)	Location for installation of LEU.	P5A Contractor to design.
n)- (v)	Arrangement of release speed in terms of clause 5.6.3.	To be advised at design stage.

n)- (vi)	Potential free contact of Cab active, forward direction and reverse direction of locomotive.	To be decided in Interface.
n)- (vii)	Details regarding type of locomotive such as Train control circuit with details of traction cut-off, battery terminal brake system details of existing wheel slip protection device etc.	To be decided in Interface.
n)- (viii)	The train parameters like length of the train, weight, deceleration factor, reaction time etc. in connection with programming of braking characteristics in the OBC.	To be advised at design stage.
o)	Any other relevant information.	Both On-board and Ground systems shall be interoperable with IR's TPWS system.

- 3) With reference to Clause 6.26 of TPWS specification Ver. 2.3 issued by RDSO on 01.08.2012, P-5A contractor shall coordinate with P5 & P17 Contractors to tap output of PSS and/ or power supply available at Location Boxes being provided by them and balance arrangement shall be provided by the Contractor.
- 4) With reference to Clause 5.10.2 of TPWS specification Ver. 2.3 issued by RDSO on 01.08.2012, facility of passing Calling-ON signal without EOA override shall be provided.
- 5) When TPWS is in Normal Mode, the train will be driven by the train driver obeying permitted speed as displayed in his DMI.
- 6) TPWS Mode shall be the normal mode of operation for the Depot access line.
- 7) Shunting operations inside the Depot shall be done in Shunting mode.
- 8) On board TPWS system shall provide mode change signal to the Driver at entry/exit of Depot.
- 9) On board TPWS system shall provide functions as per RDSO's TPWS Specification. Some of these , but not limited to, are given below:
  - (i) to get gradient, curve, signal aspect and other necessary information from track side Balise;
  - (ii) to calculate speed profile based on the information received from Balise and data base;
  - (iii) to compare continuously the current speed and target speed;
  - (iv) to apply service brake automatically when the current speed exceeds the target speed;
  - (v) to apply emergency brake automatically when the train enters into the emergency stop section or exceeds target speed beyond specified value;
  - (vi) to apply emergency brake automatically when the train enters into the overrun protection section and



- (vii) when the train cannot receive the signal from Balise, following action shall be taken:
    - (a) Home signal balise: to apply emergency brake automatically;
    - (b) Other Balise: to apply Service brake automatically.
  - (viii) to give an audio visual alarm for switching to “shunting” mode when Loco is on approach Axle Counter Track section from DFC Line to Depot Reception Signal;
  - (ix) to give an audio visual alarm for switching to “TPWS” mode when Loco is on approach Axle Counter Track section for reception on main line from depot and
  - (x) to enable download of vital data and alarms of On board TPWS for its use in OCC for display on terminals of TPWS maintainer in ELMD, Signal Fault Controller, Traffic Controller etc. These shall contain date and time stamp and train number.
- 10) Ground TPWS system shall provide functions as per RDSO's TPWS Specification. Some of these , but not limited to, are given below:
- (i) to transmit the route condition in the stations;
  - (ii) to transmit the location data from transponder provided for location adjustment to each train;
  - (iii) to transmit the location data of neutral section of OHE;
  - (iv) to interface with interlocking system and communicate the route condition and other necessary conditions The TPWS track-side system shall interface with the signalling system without affecting normal working & safety of signalling system. It shall take input regarding signal aspect through potential free contacts of the Lamp Checking relays (ECRs);
  - (v) to transmit the overrun protection data in the section where the buffer stop is provided to the train running to terminal stations and
  - (vi) to transmit the mode change signal in the section where the operation mode must change between TPWS mode (Main line) and shunting mode (in depot).
- 11) Infill Balise shall be provided for all signals provided with switchable Balise unless specifically approved otherwise for any particular signal.
- 12) Test track in Depot shall be equipped with TPWS to main line standard.
- 13) The Contractor shall submit drawings showing the DMI layout complying with Clause 6.18 and mode change switch design enable modes defined in RDSO Spec to the Engineer for review.
- 14) The structure of the mode change switch shall prevent unintentional change.

Data base storage capacity of On board TPWS shall be so designed so as to keep in view Clause 5.16 of RDSO's Spec of TPWS and the operational plan of using the Locomotive for about 3 months on main line before bringing it back to ELMD.

- 15) It shall be possible to download required On Board data when the Loco is under revenue operation. Necessary software shall be supplied to analyse

downloaded data by competent signalling staff on line as well as transmit it to ELMD for analysis by TPWS maintenance center staff.

- 16) All train borne TPWS equipment cables used by the Contractor shall be flame retardant, halogen free and low smoke emission type.
- 17) DMI shall provide indications as per RDSO's TPWS Specification. Some of these , but not limited to, are given below:
  - (i) Mode selected
  - (ii) Target speed indicator according to brake profile
  - (iii) Change mode signal
  - (iv) Emergency brake application indication
  - (v) Service brake application indication
- 18) Duplicated Doppler Radar speed sensor shall be provided wherever need is felt to ensure compliance of Clause 5.3 of RDSO specification.

#### 5.3.2 Overrun Protection system (ORP)

- 1) Objective of Overrun Protection system is to stop the train certainly before the buffer stop at terminal station.
- 2) ORP is desirable to be in-built in on-board system controlled by the location data from ground.
- 3) ORP shall be vital system.

#### 5.3.3 Temporary Speed Restriction System (TSR):

- 1) Objective of TSR is to restrict train speed in any section temporarily.
- 2) TSR shall impose the restricted speed through TPWS system.
- 3) In order to impose TSR through TPWS system, 2 temporary Balise shall be installed on both sides of TSR section. One is for TSR beginning location and other is for TSR end location.
- 4) Temporary Balise shall transmit the data of TSR and the location to on-board TPWS when train passes over it.

5.3.4 Five sets of portable automatic test tool for On Board equipment shall be provided.

### 5.4 Train Detection system

#### 5.4.1

Train Detection system being provided by P5 & P17 Contractors shall consist of Multi Section Digital Axle Counters which shall be as per RDSO specification.

### 5.5 Electronic Interlocking System (To be provided by P5 & P17 Contractors)

5.5.1 Electronic Interlocking (EI) system shall be computerized and fail safe.

5.5.2 Every station shall be provided with independent centralized EI system.

5.5.3 EI system shall be designed based on IRSEM, DFCCIL G&SR and RDSO Specifications.

5.5.4 EI system shall be independent from TD and TPWS Systems and shall continue to work even when TD or TPWS have failed.

5.5.5 The typical signalling plans for Station and Block Section are in Volume V – Reference Drawings. The P-5/ P-17 Contractor shall develop final signalling plans for all stations and Block sections detailing all routes for the Engineer's approval.

5.5.6 Only LED type signals shall be used.

5.5.7 All signals shall normally be fixed on left hand side of the track to which the signal pertains unless recommended otherwise by Signal Sighting Committee and approved by Competent Authority.

5.5.8 Where appropriate to the operating philosophy, signals at stations shall be provided with suitable route indicators.

5.5.9 Location boxes meant for UP and DN lines shall generally be located separately outside respective DFCCIL tracks. , In exceptional cases, when it is not possible to ensure the same, the Contractor shall suggest alternative method with detailed reasoning for consent by the Engineer and approval by the Employer.

## **5.6 Stations**

5.6.1 Cables from Home to Home signals in station areas will be laid in prefabricated RCC ducts (ducts to be provided by P5 & P17 Contractors) having removable covers.

## **5.7 Block sections**

General information on Signalling to be provided by P5 & P17 Contractors in Block Sections is as under:

5.7.1 Automatic Signalling will be provided with signals placed approximately every 2 kms.

5.7.2 Interlocking of Auto signals shall be done using Electronic Interlocking.

5.7.3 TD equipment, Auto signal control, Interface equipment for TMS etc. for every 5-6 Kms shall be kept in a pre-fabricated Auto Location Hut. Requirements of RDSO's TPWS specifications shall be taken into consideration while deciding location of Auto Location Huts. Specifications of Auto Location Huts are kept at Annexure 8.

5.7.4 Auto Location Huts shall be located at level crossing gates wherever feasible.

5.7.5 Auto Location Huts shall be located adjacent to Telecom Huts wherever feasible so that communication needs of Signalling can be easily met.

- 5.7.6 The Electronic Equipment Rooms in porta huts shall be provided with Panel air-conditioning and Battery/Power Supply Rooms of porta huts shall be provided with ventilation etc. as per modified Clause 10.1 of Annexure 8.
- 5.7.7 Status of Track Vacancy Detection System, signals, Level Crossing gates etc. shall be displayed in every Auto Location Hut for its controlled area and additional at least 4 Kms on either side.
- 5.7.8 Cables in Block Sections shall normally be buried direct at a depth of 1 meter on a soft bed free from pebbles and any sharp materials and covered with bricks. Detailed guidelines in Chapter 10 and Annexure 9 shall be followed for cable laying.

## **5.8 Level Crossing gates**

### **5.8.1 All level crossing gates shall be interlocked with signals by P5 & P17 Contractors keeping the following in view:**

(a) All these level crossing gates shall be replaced by ROB/ RUB in future. As such, the system design shall be such that it shall require minimum changes to initial design for the same and it shall be possible to implement the same in a cost effective and time efficient manner.

(b) Briefly, these LC Gates are as under:

- (i) 2 Nos. on link lines in Rewari – Vadodara section.
- (ii) 41 Nos. in Rewari – Vadodara main line section.
- (iii) 64 Nos. in Vadodara – JNPT main line section.

Details of all the above LC Gates are provided in Vol. IV of Bid documents.

5.8.2 The gates shall be manually operated by gateman.

## **5.9 Train Monitoring and Diagnostic System (TMS)**

5.9.1 Train Monitoring and Diagnostic System (TMS) shall be provided by P5/P17 Contractors for all Lines (excluding ELMD) as per Functional Requirement Specification (FRS) and Technical Specification kept at Annexure 1 and Annexure 2 respectively.

5.9.2 TMS system shall collect the necessary information for train operation from the signalling system (including TPWS) located on the line with Backbone Transmission system.

## **5.10 Power Supply System (PSS) (To be provided by P5/P17 Contractors)**

5.10.1 PSS shall cater to combined S&T equipment loads at stations.

5.10.2 PSS capacity at Crossing stations shall include future load with addition/ extension of loops to 1500m length as indicated in tentative Track Layout plans given in Vol. V of Bid documents.

5.10.3 In Block sections, independent PSS shall be provided for Signal and Telecom equipment huts.

- 5.10.4 PSS shall have inbuilt redundancy.
- 5.10.5 Power Supply System shall keep supplying power at full connected load at least for 4 hours during feeding power failure with at least 20% spare capacity.
- 5.10.6 Batteries provided with PSS shall consist of sealed maintenance free Valve Regulated Lead Acid (VRLA) 2 Volt cells as per RDSO specification No. IRS S:93. These shall generally consist of 2 Volt cells. However, Monoblock batteries in sizes of 6 or 12 Volts may be used in PSS of low capacity (e.g. in Block Sections) with the consent of the Engineer.
- 5.10.7 The S&T Contractors shall be responsible for provision of all power supply requirements for the Signalling System downstream of the power feed including PSS.
- 5.10.8 All power supply equipment e.g. transformers, DC-DC converters, Chargers etc. shall have one standby equipment with changeover facility.
- 5.10.9 Modules used shall be hot swappable.
- 5.10.10 The design shall take into consideration the voltage drop between the power supply source and the Signal & Telecommunication systems load (as the case may be), individually at each location (porta cabin, station etc.).
- 5.10.11 Provision of suitable earth leakage detection and alarms shall be made individually at each location (porta cabin, station etc.).
- 5.10.12 The PSS shall be designed such that failure of or restoration of the 230V AC 1 phase / 415 V AC 3 phase input supply sources shall not have any change or effect and the PSS Inverters will continue to supply to the loads without interruption. Galvanic Isolations both at the Input as well as at the inverter Outputs shall ensure that at no point of time any part of the input supply is electrically connected to the PSS Output bus. Upon restoration of the Input Supply, the PSSs and Stabilizer shall be transferred to it only after a delay and verification that there are no spikes and that the voltage has stabilized.
- 5.10.13 PSS ratings shall be subject to approval by the Engineer based on Load sizing calculations submitted by the P5/P17 Contractor during Detailed Design. P5A Contractor shall coordinate to get his requirements included in the same.
- 5.10.14 Battery sets shall be supplied only when the site is ready for commissioning of Signalling & PSS hardware is installed.
- 5.10.15 Spare Cell Charger for charging 1 to 6 Nos. of 2V cells or Monoblock batteries of 6 or 12 Volts at 10% of Battery AH Capacity shall be supplied as Spare at each station.
- 5.10.16 The P5A Contractor shall:
- i) electrically protect all individual electrical items of equipment by means of MCB. These shall be arranged to ensure that a short circuit fault on one item of equipment shall not affect the operation of other items of equipment fed from PSS;

- ii) ensure that all items of his electrical equipment are properly earthed and details shall be provided by him to demonstrate that protection is provided in the earthing concept;
- iii) ensure that any failure of TPWS power supply equipment shall be recorded and indicated at the local control maintenance panel, local ASM, Signal Fault Controller and traffic control workstations and
- iv) ensure that the design, installation and testing of the power distribution and earthing system are carried out in accordance with the requirements of IEC60364.

## 5.11 Bonding Design

5.11.1 The Contractor shall ensure that the design of Traction bonding by P-4 contractor shall not have any adverse effect on functioning of line side equipment.

## 5.12 Signage

5.12.1 The Contractor shall provide and install all railway operational signs which complement the TPWS system. These shall generally be located on trackside and shall be auto-reflective.

5.12.2 All signs shall be provided with appropriate symbols and in both Hindi and English text.

5.12.3 For example, the following signage shall be provided but not limited to:

- a) Changing sign marker at TPWS operation mode changing site e.g. at Depot entrance/exit.

5.12.4 The Contractor shall coordinate with the Engineer for the TPWS signage to be provided to meet with the overall signage requirements.

\* \* \* End of Chapter 5 \* \* \*

## 6. SYSTEM REQUIREMENTS

Item	Requirement
<b>1. TPWS system</b>	
1) Communication method between on-board and ground	It shall use Balise.
2) Speed control method on-board	On-board equipment shall calculate brake profile in accordance with received information and control brakes so as not to exceed brake profile for train protection.
3) Main Information between on-board and ground	The information shall consist of data as defined in RDSO specification of TPWS.
4) Temporary Speed Restriction method	It shall be done by Temporary Balise at start position and release position.
5) Safety level	Safety level shall comply with SIL 4 as defined in para 4.2.
6) Overrun Protection system	<b>Method:</b> It shall be ORP profile on-board based on location from ground. <b>Transponder:</b> It shall be Balise.

Item	Requirement
<b>2. Signals (by P5/P17)</b>	
1) Aspect	Four colour light aspects red, yellow, double yellow and green are required. These indicate as under: <b>Red:</b> Stop. <b>Yellow:</b> “Caution” i.e. Proceed and be prepared to stop at the next stop signal. <b>Double Yellow:</b> “Attention” i.e. Proceed and be prepared to pass next signal at such restricted speed as may be prescribed by special instructions. <b>Green:</b> Proceed Calling-ON signal shall be provided below Home signals. Position light type Shunt signals shall be provided below all Starter and Intermediate Starter signals. Independent position light type shunt signals shall be provided for exit from sidings and shunt back from Advanced Starter signals and any other location considered necessary.
2) Visual distance	Main signal: minimum 600m. Shunt signal: minimum 200m.
3) Light type	These shall be LED.

\* \* \* End of Chapter 6 \* \* \*

## 7. TECHNICAL REQUIREMENTS

### 7.1 Fail Safe Technology

- 7.1.1 The Contractor shall submit the fail safe principles adopted and supporting details about all the fail safe sub-systems.
- 7.1.2 Following sub-systems shall comply with the SIL 4 requirements as defined in para 4.2.
- TPWS system
  - Overrun Protection system

### 7.2 Foolproof Technology

- 1) Following operations, but not limited to, shall be possible with foolproof mechanism like two stage critical command, latched key, simultaneous operation with more than two (02) switches or buttons, or cooperated operation by two persons:
  - TPWS isolation mode switch on board.
- 2) The Contractor shall prepare and submit the list of such operations along with proposed method of foolproof mechanism for Engineer's review.

### 7.3 Processing Time

- 1) The Contractor shall demonstrate performance of TPWS system in terms of time elapsed between initiation of a command and completion of its execution confirmed on the DMI.
- 2) The Contractor shall attach the time chart with processing time of each sub-system in the most critical operation case at Rewari Junction Station on design stage.

### 7.4 Ergonomic Technology

- 1) Systems with man-machine interface like DMI shall be designed conducting human engineering. Especially colour for indication, switches and buttons layout for operation shall be designed with ergonomic technology.
- 2) Contractor shall state how ergonomic technology is conducted in the system.

### 7.5 Redundancy Technology

- 1) On board equipment shall normally consist of one set with two out of two hardware architecture. Any deviation shall be brought out in Technical Bid.
- 2) The Contractor is required to clarify the situation or the case precisely when the TPWS system will not cover the safety of the train operation.



\* \* \* End of Chapter 7 \* \* \*

## **8. CONTRACTOR’S COORDINATION WITH OTHERS (INTERFACE MANAGEMENT)**

### **8.1. General**

The Contractor (ST P-5A Contractor) shall interface with Other Contractors (Contractors of CT P-1, CT P-2, CT P-3, CT P-3A, EM P-4, ST P-5, PE P-6,RS P-7, CT P-11, CT P-12, CT P-13, CT P-15A, CT P-15B, EM P-16 and ST P-17, packages), Interfacing parties, relevant authorities and agencies to ensure the effective and compatible coordination of all aspects of design, installation, testing and commissioning of Works. The interface described in this document is for reference of the Contractor. This list does not in any way relieve the Contractor and the interfacing contractors of their obligations to resolve the interface issues which may be called for.

### **8.2. Contractor’s Responsibility**

8.2.1.The Contractor shall ensure that all the interface items as listed in this Specification, shall be included in the Interface Management Plan.

8.2.2. Other items not mentioned in the interface items but being relevant to the design, installation, testing and commissioning of the Permanent Works shall also be included in the Interface Management Plan.

### **8.3. Physical Interface with Other Contractors, Interfacing Parties, relevant authorities and agencies**

A number of interfaces identified during Outline Designs that shall require particular attention by the Other Contractors / Interfacing Parties, relevant authorities and agencies are given in appendices listed below:

(i)	Appendix	7-1	EM P-4, EM P-16/ST P-5A (Specific Issues)
(ii)	Appendix	7-2	ST P-5A /RS P-7 (Specific Issues)
(iii)	Appendix	7-3	ST P-5A /CT P-1, CT P-2, CT P-3, CT P-3A, CT P-11, CT P-12, CT P-13, CT P-15A and CT P-15B (Specific Issues)
(iv)	Appendix	7-4	ST P-5A /Indian Railways (Specific Issues)
(v)	Appendix	7-5	NOT USED
(vi)	Appendix	7-6	ST P-5, ST P-17/ST P-5A (Specific Issues)

### **8.4. General Definitions and Scope**

8.4.1.This covers the interface requirements between Contractor and Other Contractors/ Interfacing Parties, relevant authorities and agencies.

8.4.2. This is common to all the interfacing contracts.

8.4.3. This document shall be read in conjunction with the relevant paragraphs of the General Specification. The Contractors (the Contractor and Other Contractors) shall ensure that all requirements of the General Specification and Particular Specification pertaining to interfaces are fully resolved and implemented.

8.4.4. In the event of a conflict between the Particular Specification and the Appendices as listed above, the Contractor shall always immediately seek advice from the Engineer.

8.4.5. "Project Wide" for the purpose of the Appendices is defined as the complete Scope of Work to be executed under Contracts CT P-1, CT P-2, CT P-3, CT P-3A, EM P-4, ST P-5, PE P-6, RS P-7, CT P-11, CT P-12, CT P-13, CT P-15A, CT P-15B, EM P-16 and ST P-17 including other obligations of the Employer for successful commissioning of DFC Western Corridor Phase 1 .

8.4.6. The "Project Wide" scope for the Contractor and Other Contractors shall include both internal and external interfaces including but not limited to Indian Railways and other Utility Agencies.

8.4.7. The term "Third Parties" for the purposes of this document means all affected infrastructure owners, whose equipment is directly or indirectly affected by the Project Wide Scope of Works. This shall include Indian Railways, telecom operators, water and gas pipe line owners, emergency services, hospitals etc.

## **8.5. Contractors' Responsibilities**

8.5.1 This para outlines the Contractor's interface requirements which are based on the Technical Studies carried out during the early stages of the Project (DFC Western Corridor Phase 1 and Phase 2). However, the requirements herein specified are by no means exhaustive and it remains the Contractor's responsibility to develop, update an "Interface Management Plan" and it shall be the responsibility of the respective Other Contractors to execute the same jointly during currency of their respective Contracts, to ensure that:

- 1) All interface issues between the Contracts are satisfactorily resolved;
- 2) Supply, installation testing & commissioning, operation and maintenance of Plant & equipment are fully co-ordinated;

3) All Plant & equipment and facilities supplied under the contracts are fully compatible with each other, whilst meeting the requirements of the respective specifications.

8.5.2 The Contractors (Contractor and Other Contractors) shall jointly prepare an Interface Management Plan for exchange of information to achieve the interface requirements at an early stage in the Project, a copy of which shall be submitted to the Engineer for his consent and approval by the Employer.

## 8.6. Physical interface issues – General

### 8.6.1 Contractors' Responsibilities

8.6.1.1 EM P-4 & EM P-16 Contractors shall be responsible for the preparation of the Project Wide Management Plans for electromagnetic compatibility, earthing & bonding and systems integration for Phase 1 and Phase 2 (Makarpura - JNPT) respectively. All the Contractors shall be responsible for implementing the requirements of the Project Wide Management Plans.

8.6.1.2 The EM P-4 & EM P-16 Contractors shall act as system integrator for a number of critical interfaces between the design, construction, testing and commissioning of the Western Dedicated Freight Corridor covering the project wide scope of work.

8.6.1.3 This is required to ensure that Western Dedicated Freight Corridor is fully integrated for operation and safety.

8.6.1.4 The EM P-4 & EM P-16 Contractors shall provide Project Wide coordination for the following critical interfaces:-

- 1) Electromagnetic Compatibility (EMC) & Electromagnetic Interference (EMI);
- 2) Earthing & Bonding (E&B);
- 3) Systems Integration;
- 4) Integration Testing and Commissioning.

8.6.1.5 Each of the Contractors shall appoint a Dedicated Coordination Team led by an Interface Coordinator reporting to the respective Project Wide Contractor's Representative to perform the roles to undertake coordination of the Scope of Work within their respective contracts in regard to:-

- 1) Earthing & Bonding;
- 2) Electromagnetic Compatibility & Electromagnetic Interference;
- 3) Systems Integration.

8.6.1.6 Interface Coordinator of each of the Contractors shall be responsible for coordination of Electromagnetic Compatibility & Electromagnetic

Interference, earthing & bonding and systems integration across the whole Project.

- 8.6.1.7 All the Contractors shall fully cooperate with such Interface Coordinators identified above. Should there be any disagreement between contractors and the relevant Interface Coordinators, then the matter shall be referred to the Engineer for resolution of the issue. In case of any dispute between the Contractors with regard to Interface requirements, the matter shall be referred to the Employer for arbitration. The Employer's decision shall be final and binding on all the Contractors.

## **8.7. ELECTRICAL & PHYSICAL INTERFACE**

### **8.7.1 Electromagnetic Compatibility (EMC) & Electromagnetic Interference (EMI)**

- 8.7.1.1 The Project Wide EMC/EMI Management Plan shall fully detail the approach and processes to manage EMC across all the Works required for Design, Construction, Testing, Commissioning, Operation and Maintenance of the Project. It shall cover internal EMC interfaces within the Contractor's Scope of Work, EMC between other contracts and EMC interfaces between the Project and third parties. Preparation of the Project Wide EMC Management Plan shall be coordinated by EM P-4 & EM P-16 Contractors in association with the Other Contractors and shall be submitted to the Engineer for his consent and approval of the Employer including its each revision (if any).
- 8.7.1.2 All the Contractors shall work to and comply with the requirements of finalized Project Wide EMC/EMI Management Plan as consented by the Engineer and approved by the Employer.
- 8.7.1.3 All the Contractors shall prepare EMC control plans that contain all the information that is required by the approved Project Wide EMC Management Plan for the Project. EMC control plans shall be submitted to Engineer for his consent.
- 8.7.1.4 All the Contractors shall undertake EMC compatibility studies as required by the Project Wide EMC Management Plan. These studies shall identify all EMC risks and hazards with the respective contractor's Scope of Work and any impacts on adjacent IR route including any other third party. Where joint studies are required with IR & third parties, these shall be facilitated by the Employer. Any changes to the Project Wide EMC Management Plan, if required to as a result of EMC compatibility studies and as approved by the Engineer / Employer, shall be coordinated by EM P-4 & EM P-16 Contractors.

## **8.8. Earthing & Bonding**

- 8.8.1 EM P-4 & EM P-16 Contractors shall prepare Project Wide Earthing & Bonding Management Plans in consultation with the Other Contractors, which shall fully detail the approach and processes to manage earthing & bonding across all works required to design, construct, commission, test, operate and maintain the Western Dedicated Freight Corridor. This document shall be submitted to the Engineer for his consent and approval by the Employer including its each revision.

- 8.8.2 All the Contractors shall work to and comply with the latest revision of the Project Wide Earthing & Bonding Management Plan.
- 8.8.3 All the Contractors shall prepare Earthing & Bonding Strategies and designs based on the requirements of the Project Wide Earthing & Bonding Management Plan. These shall be submitted to the Engineer for his consent. The finalized Earthing & Bonding Strategies and designs shall be submitted to Interface Co-ordinators of EM P-4 & EM P-16 Contracts as per the agreed programme.
- 8.8.4 The Interface Coordinators of EM P-4 & EM P-16 Contracts shall chair Earthing & Bonding integration meetings for Phase 1 & 2 respectively to resolve earthing & bonding issues between the Contractor and Other Contractors and third parties. All contractors shall then revise their Earthing & Bonding strategies and designs accordingly, if required. Any issues that are not resolved shall be notified to the Engineer for resolution. In case of any dispute, the matter shall be referred to the Employer for arbitration. The Employer's decision shall then be final and binding on all the Contractors.
- 8.8.5 The Interface Coordinators of EM P-4 & EM P-16 Contracts shall integrate all of the Contractors Earthing & Bonding strategies into single Project Wide Earthing and Bonding Strategy for Phase 1 & 2 respectively that shall be mandated across the whole Project and which all the Contractors shall fully comply.
- 8.8.6 Agreed Earthing and Bonding drawings shall be signed jointly by EM P-4/EM P-16 and ST P-5A contractors.

#### **8.9. ANTI THEFT CHARGING OF OHE**

- 8.9.1 As an anti-theft measure, the OHE after erection may be charged at 2.2 kV by EM P-4/EM P-16 Contractors. However, before such anti-theft charging, which shall require certain precautions and safety measures to be taken by personnel of all the Contractors and of employees of adjacent railway system, the following precautions need to be followed. The precautions shall include but not limited to:-
- Issue of public notice in local newspapers for information to public.
  - Notice to adjacent Indian railway administration.
  - Procedure providing for issue and cancellation or permit to work on or in vicinity (within two meters of the live conductors & 25 KV equipment) to all concerned through and to authorized personnel as a requirement before the lines can be charged as an antitheft measure.
  - 24 hour monitoring of the section and its patrolling.
  - Permission of E.I.G.
  - DOT (Department Of Telecom) clearance
- 8.9.2 EM P-4 & EM P-16 Contractors shall give notice to the Other Contractors in this regard. The Other Contractors shall take necessary precautions while carrying out the Works keeping in view the anti-theft charging of OHE.

8.9.3 This antitheft charging shall not be done until no objection is received from the Engineer and Employer and confirmation received from him that Engineer's & Employer's staff have been warned of the hazards of adjacent line of DFC being charged and have been trained on the precautions required to be taken by them.

8.9.4 Detailed procedures and rules shall be prepared by the Contractor and submitted to the Engineer for his consent & issue to all the concerned.

## **8.10. Systems Integration Requirements**

8.10.1 The EM P-4 & EM P-16 Contractors shall prepare Project Wide Systems Integration Management Plans. The Project Wide Systems Integration Management Plan shall fully detail the approach and processes to manage systems integration across all the Works required to design, construct, commission, test, operate and maintain the Project.

8.10.2 The Systems Integration Management Plan shall cover internal systems integration within the Contractor's Scope of Work, systems integration between the other contracts and systems integration interfaces between the Project and third parties including Indian Railways. This document shall be submitted to the Engineer for his consent and Employer for approval including its each revision, if any. All the Contractors shall work to and comply with the latest revision of this plan and shall prepare a system integration strategy which shall be submitted to the Engineer for his consent. The system integration strategy, as consented by the Engineer, shall be forwarded to the Interface Coordinator of EM P-4 & EM P-16 Contracts.

8.10.3 The EM P-4 & EM P-16 Contractors shall integrate all the Contractor's system integration strategies into respective single documents with all interfaces agreed.

8.10.4 Prior to commissioning of any system, the ST P-5A Contractor shall prepare an Integrated Test Plan, detailing of tests to be undertaken to verify the functionality of the systems he is responsible for and to ensure that there are no adverse effects on Other Contractors or third party Works. Integrated Test Plan shall be submitted to the Engineer for his consent and approval by the Employer

8.10.5 All the Contractors shall prepare Systems Integrated Testing Plan and submit the same to Engineer for his consent and approval of the Employer. The Interface Coordinator of EM P-4 & EM P-16 Contractors shall combine all contractor's and third party Systems Integration Testing Plans into respective single test plans, The plan shall cover as a minimum:-

- a) Systems and sub systems to be tested;
- b) Tests to be performed;
- c) Requirements from Other Contractors (e.g. Locomotives or systems to be provided with instruments to obtain data from other contractor's systems);
- d) Test equipment to be used;
- e) Programme of earthing and bonding;
- f) Safety requirements for the test (e.g. suspension of service on Indian Railways or no staff other than test engineers on site);
- g) Test pass/ fail criteria.

- 8.10.6 All the Contractors shall provide, generate or supply reasonable test data to each other; as identified in the Project Wide Systems integrated Test Plan.
- 8.10.7 The ST P-5A Contractor shall prepare a joint Test Report duly signed by him and Other Contractors within 2 weeks of the test being performed and submit it to the Engineer.
- The Contractors shall immediately notify the Engineer and Interface Coordination Managers of EM P-4 & EM P-16 Contracts of test failures, if any.
- 8.10.8 Any modification to the Contractor's or any of the Other Contractor's equipment, if required, to rectify the integration issues shall be undertaken by the respective contractor(s). Any modification requirements to third party infrastructure shall be notified to the Engineer for completion of work by the third party which shall be coordinated by the Employer.
- 8.10.9 The final integrated test reports shall be used to substantiate the case for safe operation of the Project.
- 8.10.10 The test report, test measurement data and test plans shall form part of the As Built / As Erected records.

\* \* \* End of Chapter 8 \* \* \*



## 9. TESTING, COMMISSIONING AND VERIFICATION

### 9.1 General

- (1) The Contractor shall provide and perform all types of tests applicable to the Works.
- (2) All materials, goods, equipment and manufacturing processes for the Works shall be subjected to inspection and the witnessing of tests by the Engineer unless otherwise agreed in writing by the Engineer.
- (3) The Engineer and/or any of their staff shall have the facility to monitor all tests and have access to all test records. Sufficient time shall be allowed within the testing programmes for necessary alternations to equipment, systems and designs to be undertaken, together with re-testing prior to final commissioning.
- (4) Tests to be conducted by the Contractor shall be carried out in accordance with the requirements of the Contract.
- (5) The inspections and tests shall be divided into following basic stages;
  - (i) Type test;
  - (ii) Routine tests carried out before offering for FAT;
  - (iii) Factory Acceptance Tests (FAT) carried out before delivery of equipment;
  - (iv) Site acceptance and integrated test;
  - (v) Trial runs.
- (6) The inspection and passing of work or equipment by the Engineer shall not relieve the Contractor from his obligations, responsibilities and liabilities to complete the Works in accordance with the Contract nor relieve him of any of his obligations, responsibilities and liabilities under the Contract.

### 9.2 Test Plan and Procedures

- (1) All test plans and procedures shall be submitted for the review of the Engineer at least 30 days prior to conduction of any test together with the exact time and date of such test. Test procedures shall show the following unambiguously but not limited to:
  - a) date on which the Contractor proposes to conduct each of these listed tests;
  - b) nature and purpose of test;
  - c) extent of testing covered by each submission;
  - d) method of testing and test requirements with the relevant standards;
  - e) relevant drawing and document (or modification) status;
  - f) location of testing;
  - g) test parameters to be measured with the relevant standards;
  - h) constraints to be applied during the test with the relevant standards;

- i) defined pass/fail criteria with relevant standards;
  - j) format of the raw data for processing by the Contractor;
  - k) test instrumentation and test circuitry to be used during the test with the relevant standards.
- (2) Test procedures may be amended during the duration of the Contract to reflect changes in design or the identification of additional testing requirements.

### 9.3 Costs of Tests

- (1) (a) All costs associated with provision of test facilities including test materials, test equipment, meters, instruments, raw materials etc. to enable carrying out of testing shall be borne by the Contractor.
- (b) Testing charges payable to RDSO or any other agency engaged by the Employer for this purpose shall be borne by the Employer.
- (c) Expenses of Travel, Hotel and Daily Allowance of the Employer/Engineer for inspection or witness (except cases mentioned in item (2) below) shall be borne by the Employer.
- (2) If an agreed test is not acceptable as proposed due to absence of approved Test plan and procedures and/or Reports, failure to fulfil the pass/fail criteria, lack of preparation, negligence or material and/or equipment being presented in a state which is clearly not acceptable, all costs incurred by the Employer and/or Engineer for repeated inspection and/or witness shall be borne by the Contractor.

### 9.4 Records of Tests

- (1) Within fourteen (14) days after completion of any test, all necessary information regarding the test shall be submitted in a report for the Engineer's review. If required by the Engineer, a manuscript copy of the test record shall be made at the time of the test and given to the Engineer or at the earliest opportunity if the test has not been witnessed. On completion of each test or group of tests, the Contractor shall provide a signed and stamped test report containing following details:
- a) number and types of tests which are required by the Specification and the results to be achieved;
  - b) tests actually carried out and the results actually achieved;
  - c) confirmation of pass/failure accompanied with, if necessary, a schedule of further tests or actions to be carried out by the Contractor to achieve compliance with the Specification and the approved design.
- (2) In addition to any other requirements, the report and its supporting documentation for the tests done by the Contractor for the Engineer's inspection and audit, shall contain the following details:
- a) equipment, system, facilities or part of the Works tested;

- b) location and size of the batch from which the samples were taken or the location of the part of the Works;
- c) reference to test procedures and test schedule;
- d) place of testing;
- e) date and time of tests;
- f) weather conditions in the case of in-situ tests;
- g) Names & designations of the technical personnel supervising or carrying out the tests;
- h) size and description of samples;
- i) method of sampling;
- j) properties tested;
- k) readings and measurements taken during the tests;
- l) test results, including any calculations and graphs;
- m) specified acceptance criteria;
- n) List of measuring instruments used along with its Serial No., Make, name of authorised lab where last calibration was carried out and date up to which its calibration is valid;
- o) other details required by the Contract.

### **9.5 Sources of equipment supply**

- (1) Equipment procured locally shall be from RDSO's "Approved list of firms for manufacture and supply" and as per relevant specifications.
- (2) If any equipment proposed to be imported has RDSO specifications (IRS or SPN) and is not yet having Cross Acceptance approval (by RDSO/ DFCCIL), the concerned firm shall be got approved for the said equipment as per "Cross Acceptance" procedure of RDSO/ DFCCIL before commencement of Integrated Testing on Rewari – Iqbalgarh section.
- (3) If any equipment other than covered in item (1) and (2) above is proposed to be supplied, then the same must be proven being in regular use for at least last 2 years . Details of the same shall be submitted well in advance for review without objection by the Engineer.

### **9.6 Type Tests**

- (1) If the Contractor proposes to supply any equipment not approved as per para 9.5 above, the Contractor shall undertake the type testing of pre-production units to the satisfaction of the Engineer. The Contractor shall identify in its design submissions any equipment in this category.

- (2) Type tests shall be carried out on specific items to ensure that they perform their intended functions when subjected to all permutations and combinations of external environment and other factors. These may be omitted where the Contractor is able to produce documentation from previous test that meets the requirements of the Engineer.
- (3) In addition to the above, Type tests may also be performed for subsystems, components and items of equipment installed in the overall system in substantial numbers. In this case, the Test Program shall foresee a combined schedule of Type Tests and corresponding Routine Tests of individual units.
- (4) Type tests on equipment for which RDSO specifications exist, shall be as per relevant RDSO specification.
- (5) Type test Reports and Certificates shall explicitly state the mandatory contents of the routine test program and the individual inspection and measurement procedures that need to be performed on each individual item of identical series production devices or components.

## 9.7 Types of tests

### 9.7.1 General

- (1) All equipment, materials and software shall be tested during manufacture and before delivery.
- (2) Following types of tests are required to be conducted but not limited to:
  - a) Routine tests;
  - b) Environmental (EMC/EMI) tests;
  - c) Interface protocol tests;
  - d) Software tests;
  - e) Factory Acceptance Tests (FAT);
  - f) Site acceptance and integrated tests;
  - g) Trial runs.

### 9.7.2 Routine tests

- (1) Routine tests shall be conducted on all equipment during the process of manufacture. The routine tests shall include:
  - a) Visual inspection

Visual inspections shall be carried out to ensure that the equipment is of sound construction and meets the requirements.
  - b) Diagnostic tests

Hardware diagnostic tests shall be carried out on each element of the system including all workstations, computers, computer peripherals, devices.

c) Performance tests

Performance tests shall consist of a comprehensive series of measurements on the characteristics of the individual equipment to check if its performance is complying with the performance and functional requirements of the particular equipment concerned.

d) Soak tests

Equipment shall be set up in a manner to simulate normal operating conditions, switched on and allowed continuous operation for a minimum period of 100 hours. This period may be broken down into shorter period if compatible with the function of the equipment.

- (2) Routine test reports shall be submitted to the Engineer before inviting him for FAT.

### 9.7.3 Environmental (EMC/EMI) tests

- (1) All equipment supplied shall be tested in accordance to the EMC requirements defined in IEC 62236 Series : Railway applications – Electromagnetic Compatibility or relevant standard.
- (2) All supplied equipment shall be tested for full operational ability under the conceivable environmental conditions.
- (3) Environmental tests may not be required if previous independent witnessed tests have been successfully carried out and reported by document.
- (4) If any failure occurs during the environmental tests or the equipment design is changed, it shall be reported to the Engineer who may at his discretion require repetition of the tests.
- (5) Proximity of IR's 25KV RE lines shall be taken into account while determining prevalent environment for such tests.

### 9.7.4 Interface Protocol Tests

- (1) Interface Protocol tests are required for the following, but not limited to, software interfaces:
  - a) Interface between Onboard TPWS and loco braking.
- (2) Actual equipment shall be used for these interface protocol tests. Protocol simulators are not allowed.

### 9.7.5 Software Tests

The Contractor shall carry out the software proofing tests based on the Employer's requirement, but not limited to the following:

- a) Data base mapping/ Man-Machine Interface (MMI) validation tests for TPWS, each station and Block section;
- b) point-to-point tests;
- c) functional tests;

- d) performance tests and

#### 9.7.6 Factory Acceptance Tests

- (1) Factory Acceptance Tests of materials and equipment procured locally and having RDSO specifications (IRS or SPN) or appearing in RDSO's list of Approved Vendors shall be got done by RDSO.
- (2) All equipment, components, sub-assemblies, unit assemblies (including software, cables and wiring) shall be subjected to factory acceptance test. Notification of these tests shall be submitted to the Engineer 30 days in advance of carrying out any test together with information on any previous testing which relates to the items being tested. The Engineer will then determine to witness such test or which, if any, items may be accepted based on previous supply or experience.
- (3) Factory Acceptance Tests shall include but not limited to:
  - a) physical inspection;
  - b) dimension check;
  - c) electrical check;
  - d) calibration;
  - e) output check;
  - f) operational performance including full functional software testing;
  - g) Insulation test;
  - h) soak test.

#### 9.7.7 Site Acceptance Tests and Integrated Tests

- (1) The site acceptance and Integrated tests shall be carried out on site after installation, which shall demonstrate that system and software meets the Employer's requirements in terms of functionality and performance.
- (2) Site acceptance and Integrated tests shall include but not be limited to the following categories of tests:
  - a) Site acceptance tests:

The tests shall ensure that all the equipment supplied under this Contract satisfy the functional and performance requirements of the Employer's requirements when operated in a standalone manner without any interface to equipment/system supplied by other Contractors.
  - b) Integrated tests with other contractors:

The tests shall ensure that all the interfaces with other Contractors satisfy the functional and performance requirements of the interface requirements.
  - c) Total system integration tests:

Having completed the integrated tests with respective contractors individually, total system integration test shall be performed to

demonstrate that all system modules can co-ordinate their works with each other in harmony and that all functional and performance requirements are satisfied. No crash or abnormality shall result from having various combinations of possible operations being carried out simultaneously.

- (3) The scope of the site acceptance and integrated tests shall cover but not be limited to the following:
- a) Visual inspection to ensure the equipment is installed properly in accordance with the installation submissions;
  - b) Electrical tests to ensure that the electrical connections of the cables, power modules, electronic modules, etc. are correct;
  - c) Operational performance including full functional software testing;
  - d) Communication tests between data transmission equipment;
  - e) Functional tests on all the control requirements;
  - f) Point-to-Point tests to ensure correct mapping between the database and the physical equipment I/O points. Failed I/O points to be listed to show that routing is still functioning;
  - g) End-to-End tests to ensure that all the connected plant can be controlled and/or monitored.

#### 9.7.8 **Compatibility test of TPWS**

Compatibility between On board TPWS of DFCCIL with Line side TPWS of IR and vice versa shall be tested. For this, initial section of about 60Kms. of DFCCIL track shall be made ready. Section of IR where On board TPWS of DFCCIL shall be tested shall be got decided by the Engineer.

#### 9.7.9 **Trial Runs**

Trial Runs may be referred to in General Specification.

\* \* \* End of Chapter 9 \* \* \*

## 10. INSTALLATION

### 10.1 General

- 10.1.1 The Contractor shall supervise all installation of the Works and shall ensure that all technical, safety and quality matters adhere to the Design as reviewed by the Engineer.
- 10.1.2 The Contractor shall take every precaution to protect existing equipment and facilities on Site from damage, and shall make good any damage caused. Care shall also be taken not to interfere with the operation of existing equipment.
- 10.1.3 The Contractor shall provide all necessary and sufficient resources such as tools, test instruments, spares, equipment, manpower and communication facilities to complete all the installation activities.
- 10.1.4 The Contractor shall ensure that his staff are competent and possess all the necessary skills to carry out the installation in a proper and safe manner.
- 10.1.5 The Contractor shall carry out site surveys to ensure sufficient knowledge of the Site before submitting the relevant installation drawings and installation related submissions to the Engineer for review.
- 10.1.6 The Contractor shall submit installation method statements for each type of installation activities at least three months before the commencement of the activity to the Engineer for review.
- 10.1.7 The installation method statement shall include the details on the methods and procedures of installation, site arrangement, manpower resources, equipment and tools required. Drawings shall be included to illustrate the proposed installation details.
- 10.1.8 All installation activities shall commence only after the method statement and related submissions have been reviewed without objection by the Engineer.
- 10.1.9 The Contractor shall assign competent site supervisors for each work site to be responsible for all site related matters.
- 10.1.10 The Contractor shall carry out regular site audit on both technical and safety matters and maintain records of the site audits. The Contractor shall make these records available to the Engineer for inspection upon request.

### 10.2 Installation Programme

- 10.2.1 The Contractor shall submit an Installation Programme for review by the Engineer.
- 10.2.2 The Contractor shall co-ordinate with relevant Project Contractors to agree with the date of access to the physical areas to carry out installation activities.
- 10.2.3 The Contractor shall develop the Installation Programme and take the following into account:
- (1) Installation schedule;



- (2) Key Dates and Milestones;
  - (3) site access;
  - (4) interfacing with relevant Project Contractors.
- 10.2.4 The Contractor shall highlight in his Installation Programme the resources and supports, if any, to be provided by the Engineer with dates, duration and locations.
- 10.2.5 The Contractor shall also highlight all relevant constraints, which may affect the Installation Programme, to the Engineer's attention.
- 10.2.6 The Contractor shall include dependencies between relevant activities in the Installation Programme.
- 10.2.7 The Contractor shall ensure sufficient floats or slacks in all activities and avoid critical paths built in his Installation Programme. In case critical paths cannot be avoided, the Contractor shall highlight any critical paths for the Engineer's attention.
- 10.2.8 The Contractor shall propose contingency plan to ensure that all the major Key Dates and Milestones can be met in case there is slippage in the installation activities.
- 10.2.9 Any subsequent changes in the reviewed Installation Programme shall be submitted to the Engineer for review.

### **10.3 Installation Works**

#### **10.3.1 Installation in Equipment Rooms**

- 10.3.1.1 The following equipment rooms will be provided by Civil Works Project Contractors to install the Signalling equipment:

- (1) Signalling Equipment Room (SER) at stations;
- (2) Central Equipment Room at OCC;
- (3) S&T Power Supply Room;
- (4) Gate Lodge.

- 10.3.1.2 Signalling Equipment Room (SER) is reserved for the installation of the signalling equipment, which is local to each station and its adjacent track sections. The SER will be equipped with air conditioning systems, lighting and power outlets provided by the Civil Contractors. S&T Power Supply/Battery Rooms at the stations shall be provided with ventilation by the Civil Contractors.

- 10.3.1.3 All items of local signalling equipment comprising active electrical and electronic components shall be located to the maximum extent possible in the SER and not on the trackside.

- 10.3.1.4 Electric power to the S&T Power supply room shall be drawn by ST P-5/ST P-17 Contractors from selection of the power supply switch which will be provided by other Project Contractor.

- 10.3.1.5 For exact room dimensions, the Contractor shall however co-ordinate and refer to the final station building plans.
- 10.3.1.6 The Contractor shall liaise with the Engineer and relevant Project Contractors for access to the equipment rooms for installation.
- 10.3.1.7 All floor mounted equipment cabinets at the equipment room shall be securely bolted to ground, properly aligned and levelled.
- 10.3.1.8 All wall-mounted equipment shall be installed at appropriate height to avoid any hazards to the person passing by. The Contractor shall ensure the fixture is of sufficient strength to hold the wall-mounted equipment in a secure and safe manner.
- 10.3.1.9 The floor mounted equipment cabinets shall be arranged in the way to allow sufficient space at the front and rear side of the cabinets for maintenance access. Sufficient space shall also be allowed for front maintenance access of the wall mounted equipment.
- 10.3.1.10 The equipment layout within the equipment room shall be designed to allow sufficient clearance for escape out of the equipment rooms in case of emergency.
- 10.3.1.11 The Contractor shall submit the following to the Engineer for review at least three months before the commencement of the installation inside the equipment room:
- (1) drawings showing the equipment layouts and positions of the racks, cabinets and enclosures;
  - (2) racks, cabinets layout drawings showing the arrangement of individual module;
  - (3) specifications, sample of all the mounting brackets and accessories;
  - (4) equipment mounting and installation methods;
  - (5) schematic diagrams and wiring diagrams of the System;
  - (6) electrical distribution schematics within the room including the earthing details;
  - (7) cable route diagrams for cables within the room.

For item nos. 1, 2 & 7 above, the Contractor shall incorporate details pertaining to his works in the drawings prepared by P5/P17 Contractors. These changes shall be got agreed by P5/P17 Contractors before submission to the Engineer.

- 10.3.1.12 Installation work inside the room shall be carried only after these submissions have been reviewed without objection by the Engineer.

## 10.3.2 Outdoor Installation

- 10.3.2.1 The Contractor shall coordinate with P5/P17 Contractors to lay cables in ducts/troughs provided by them. For details, refer Annexure 7-6.

- 10.3.2.2 All the mounting brackets and accessories shall be corrosion resistant, aesthetically designed to match with all architectural finishes and of sufficient strength to mount the equipment securely.
- 10.3.2.3 The Contractor shall submit the following to the Engineer for review at least three months before the commencement of the installation activities:
- (1) specifications, sample of all the mounting brackets and accessories;
  - (2) equipment mounting and installation methods;
  - (3) schematic diagrams and wiring diagrams of the System.
- 10.3.2.4 If the equipment is installed at locations exposed to direct sunlight, the equipment, mounting brackets, cables and accessories shall be made of materials which are resistant to ultra violet rays.
- 10.3.2.5 All trackside equipment and the mounting method shall be designed in a way to minimize the frequency of preventive maintenance.
- 10.3.3 Installation of On board TPWS Equipment
- 10.3.3.1 On board TPWS equipment including antenna shall be installed in each of the Electric Locomotives. The cabinet, cabling, connectors and terminal strips, antenna, power supply units, Odometer, DMI etc. shall be manufactured & supplied by the P5A Contractor. Supervision of installation for first few locos (say 4) will be done by P5A contractor at the Rolling Stock Contractor's work place simultaneously training P7 staff so that installation on balance locos can be done independently by them. P5A Contractor shall also supervise installation of on board equipment for first two locos of CKD/SKD at nominated Workshop for TOT in coordination with P7 Contractor simultaneously training Workshop staff so that installation on locos can be done independently by them.
- 10.3.3.2 The mounting of the TPWS cabinet and its subassemblies shall be designed to facilitate ease of maintenance.
- 10.3.3.3 All cabling and terminations shall adopt standard wiring practice.
- 10.3.3.4 On board TPWS installation shall be rugged and capable of withstanding vibrations expected in such type of Electric Locomotives. Information on expected level of vibration may be obtained from Contractor of P7 contract package for Procurement-cum-maintenance of Electric Locomotives.
- 10.3.3.5 The Contractor shall submit interface document agreed with P7 Contractor containing at least the following to the Engineer for review at least 3 months before the commencement of TPWS installation in the Cabs:

- (1) drawing showing equipment layout, racks, cabinets and enclosures;
- (2) racks,& cabinets layout drawings showing the arrangements of individual modules;
- (3) schematic diagrams and wiring diagrams of the system;
- (4) electric power requirements, wiring and earthing arrangements;
- (5) inter cab (front and rear cabs of the same Electric Locomotive) cabling requirements.

10.3.3.6 Installation works in the cabs and inter cab wiring shall be carried out after the submissions have been reviewed without objection by the Engineer.

## 10.4 Cabling

10.4.1 RDSO's Guidelines on Signalling Cable Laying kept as Annexure 9 shall be followed in general. Any deviation to the same shall require prior approval of the Engineer.

10.4.2 Quad cable used shall be Jelly filled type.

10.4.3 Cables and wires used for On-Board TPWS equipment shall be FRLS type.

10.4.4 All cable routes shall be carefully coordinated with those of other system Contractors whether provided by the Contractor or third parties and when passing through Station areas.

10.4.5 NOT USED

10.4.6 Primary cable containment in station areas and along track-side will be provided by P5/P17 Contractors. DWC HDPE pipes for required track, platform and road crossings shall be provided by Civil Contractors for which P5A contractor shall have to suitably interface with them.

10.4.7 Cable containment on steel girder bridges shall be provided by P5A contractor as per guidelines contained in para 10.4.1 above.

10.4.8 The Contractor shall provide all necessary secondary cable containment and supports, if necessary, to complete the connection to the Contractor's equipment.

10.4.9 All cables shall be neatly run and fitted in ducts or conduits, laid in trunkings, formed trenches or troughs, or supported by trays, hangers or cleats as appropriate.

10.4.10 Before commencing work on any part of the Site, the Contractor shall ascertain that the Engineer and also, where applicable, the local and statutory authorities or other bodies/persons concerned have reviewed each cable route without objection. The Contractor shall further ensure that all necessary permits in such cases have been obtained and notices served.

10.4.11 The Contractor shall provide his own brackets and clips to secure all the cables at an adequate interval. Where cables are to be laid in troughs, the Contractor shall remove and re-instate trough covers prior to and after cable installation.

- 10.4.12 A labelling scheme shall be applied for all cables installed. Each cable shall be uniquely identified. Labels shall be tied at both ends, at entry and exit points of cable trays, ducts and trenches and at appropriate locations where necessary. Labels shall be provided at about every 100m spacing in complete length of every cable. Type of labels to be used shall be got approved by the Engineer.
- 10.4.13 Cable drums shall always be mounted on jack and rotated for uncoiling and paying out of cable. Cable shall not be pulled for this purpose.
- 10.4.14 Cable drum shall never be kept on its side and cable uncoiled. Since this can result in twisting of cable conductors resulting in damage to them, any such instance noticed will result in the following liabilities on the Contractor:
- (a) Remove such laid cable and cut into pieces of scrap of about 2 metres each;
  - (b) Lay new cable in lieu.
- 10.4.15 The installation and handling of cables shall be undertaken at all times by adequate staff suitably trained and supplied with all necessary plant, equipment and tools. The arrangement of the cables and all methods of laying shall be planned to provide an orderly formation, free from unnecessary bends and crossings. Following principles for laying of cables shall be adopted during track crossings:
- (1) The cable crosses the track at right angle.
  - (2) The cable does not cross the track under points and crossings.
  - (3) The cable is laid in DWC HDPE pipes while crossing the track.
- 10.4.16 At culverts, the cables shall be suitably supported and protected with DWC HDPE pipes.
- 10.4.17 All cables shall be laid within the WDFC boundary. If it is necessary to lay the cable outside the WDFC boundary, permission shall be obtained before starting the trenching.
- 10.4.18 Digging of trench between IR track and WDFC track shall be manual or mechanized depending on availability of ROW. This shall be got agreed by the Engineer for every station/ Block section separately.
- 10.4.19 Cables in any conduits, trunkings or ducts shall not occupy cross-sectional space in excess of 50%.
- 10.4.20 At no location shall the cable be bent with a radius lower than the minimum radius recommended by the manufacturer. Sharp edges shall be avoided.
- 10.4.21 Every precaution shall be taken to ensure that cables and equipment are not installed in a manner or under conditions likely to cause electrolytic or other corrosive action or damage to, or be detrimental to, the performance of the cables and equipment during operation.
- 10.4.22 Signalling cables shall not run with cables carrying high voltages or heavy currents and shall conform to the requirements specified in BS 7671.

- 10.4.23 Wherever both Signalling & Telecom cables are to be laid in the same trench/duct, common trench/duct may be used with brick separation between the two.
- 10.4.24 Signalling tail cables shall be mechanically protected to avoid being damaged from track side maintenance activities and shall be immune to any malfunction from electromagnetic interference.
- 10.4.25 All cables shall be adequately rated for their duties. All power cables shall be able to withstand full load current for peak operation when the equipment is at its ultimate capacity. The Contractor shall comply with the latest edition of IEE Wiring Regulations.
- 10.4.26 Unused cable cores/pairs of multi-core/pair cables shall also be terminated and marked so.
- 10.4.27 No underground jointing of cables shall be permitted.
- 10.4.28 Electronic Cable markers of proven make shall be provided for outdoor cables laid in trenches dug by P-5A Contractor spacing of which shall be got approved by the Engineer.

## **10.5 Marshalling and Termination**

### **10.5.1 General**

- 10.5.1.1 All Location Boxes shall be prewired at a convenient site office of the Contractor to the extent possible and tested before being shifted to site for installation.
- 10.5.1.2 Crimping or other standard industry practice shall be used for terminating all conductors. Solder terminations shall only be used with the approval of the Engineer.
- 10.5.1.3 Wherever practical, multiple pin plugs and sockets shall be used to connect multi-core cables and wiring looms to all items of equipment. These shall have some form of keying to prevent incorrect equipment modules from being installed.
- 10.5.1.4 All wire and cable conductors shall be clearly identified at each end using durable shrink-on or tag type labels.
- 10.5.1.5 All wire and cable terminals shall be numbered and identified using appropriate tag type labels. A description of the terminating function shall be included.
- 10.5.1.6 The cables laid on trays shall be suitably marshalled for easy identification.
- 10.5.1.7 The cable terminations shall be secure enough to withstand vibration level, which is likely to be experienced in the railway environment.

### **10.5.2 Cable Termination Rack (CTR)**

- 10.5.2.1 Cable Termination Rack (CTR) with 20% extra capacity for future expansion shall be provided in Signalling Equipment Room and Auto Location Huts.
- 10.5.2.2 Only screw-less terminals with isolation facility as per RDSO specification shall be used for cable terminations and fuse holders. These shall be got approved by the Engineer.
- 10.5.2.3 The outgoing circuits connecting to external circuits liable for lightning or high induced voltage, lightning arrestors and surge protection devices shall be provided with the required earth connections. For details of this protection, please refer to para 10.8 (Lightning and Surge Protection).
- 10.5.2.4 The Cable Termination Rack (CTR) shall be equipped with copper earth bar to which all cable shields shall be connected. The copper earth bar shall be connected to the earth. For details please refer to para 10.7 (Earthing).

### 10.5.3 SER/Trackside Interfaces

- 10.5.3.1 All interfaces between SER equipment and trackside equipment shall be via easily removable railway Signalling type fuses or shorting links as appropriate. The design of these links shall make it possible to measure all current and voltage levels at these interfaces. By removing these links, it shall also be possible to completely isolate both the outgoing and return feeds of each interface circuit.
- 10.5.3.2 All interfaces to trackside equipment shall be provided with adequate lightning protection devices in order to prevent any sensitive electronic equipment connected to them from being damaged.

## 10.6 Labelling

- 10.6.1 Descriptive labels shall be provided for all cabinets, enclosures, panels, assemblies and sub-assemblies.
- 10.6.2 Labels shall be of engraved type, with durable markings and shall have character size not less than 6mm high.
- 10.6.3 The details of the labels including the material and size of the characters and sample of the labels shall be submitted to the Engineer for review.
- 10.6.4 Labels and notices on equipment shall be fixed with roundhead brass screws or self tapping screws. Stick-on labels or fixing by adhesive shall not be accepted.
- 10.6.5 All enclosures containing terminals or exposed live parts where a voltage exceeds 120 volts shall have a label with lettering indicating the maximum voltage present in the enclosure.
- 10.6.6 Warning signs shall be provided with graphical symbols and wordings in red for hazardous electrical equipment.

## 10.7 Earthing

- 10.7.1 General

- 10.7.1.1 Earthing shall be provided for all indoor & outdoor TPWS installations to achieve the following objectives:
- (1) to provide the safety to the operating & maintenance personnel against the electric shock on account of any potential (voltage) appearing on exposed parts with respect to earth or due to electromagnetic or electrostatic induction;
  - (2) to ensure safe & reliable operation of the equipment by limiting or eliminating the induced voltages and transients in the TPWS equipment;
  - (3) to protect the equipment against build up of unduly high voltages, which can cause dielectric (Insulation) breakdown or damage to the equipment or their parts;
- 10.7.1.2 Earthing and other protective measures in the following paras are given only as indicative guidelines. P5A contractor shall design, manufacture, install and be responsible for safe and correct working of all equipment/subsystems under the scope of the contract.
- 10.7.1.3 P5A contractor shall submit the design for earthing, surge and lightning protection of all TPWS equipment for review and approval. OEM's original data sheets of the proposed devices shall also be submitted.

#### 10.7.2 Requirements of effective Earthing

- 10.7.2.1 The Earthing system shall meet or exceed the requirements of IEEE 1100, NFPA 780 and IEC 62305 or relevant International standards.
- 10.7.2.2 Earthing and other protection devices shall be designed to accomplish the following minimum requirements but not limited to:
- (1) protect personnel and equipment from electrical hazards, including lightning;
  - (2) reduce potential to system neutrals;
  - (3) reduce or eliminate the effects of electrostatic and electromagnetic interference arising from within the WDFC on account of traction voltages, traction return current, electric locomotive characteristics and other extraneous sources and
  - (4) provide a proper earthing method for all equipment enclosures, cabinets, drawers, assemblies and sub-assemblies.
- 10.7.2.3 The earthing system shall be so designed so as to give earth resistance within 1 Ohm at all locations and under all climatic conditions.



- 10.7.2.4 Any electrical joints in the earthing system shall be properly brazed and protected from moisture ingress by using proper wrapping, sealing with waterproof tapes, or such other measures.
- 10.7.2.5 For the purpose of measurement of earth resistance, a small interconnecting copper strip of appropriate cross-section shall be provided in the ring earth in a small manhole chamber so that the ring earth can be broken from the loop.
- 10.7.2.6 The earthing methods, design and details shall be submitted to the Engineer for review and approval.

#### 10.7.3 Earthing of indoor equipment

- 10.7.3.1 ST P-5/ST P-17 Contractors shall extend Main earth provided in the station by Civil Contractor to S&T equipment rooms. P5/P17 Contractors shall provide earthing cable of minimum 16 mm<sup>2</sup> from the PSS room to the Signal Equipment Room (SER) and terminate on copper earthing strips of sufficient size and specifications. These earthing strips shall be used by P5A Contractor to extend individual earths to cables and racks/equipment etc.
- 10.7.3.2 In order to ensure a captive earth connection to the cabinets and racks in SER, a minimum cross-section of 16 mm<sup>2</sup> copper cable must be used for earthing.
- 10.7.3.3 The cabinets within a row shall be conductively connected by means of screws and contact washers.
- 10.7.3.4 In case that one of the cabinets/racks is removed, it must be ensured that the other cabinets in the row remain earthed. To ensure this, individual equipment racks shall be earthed by individual cables from earthing strips & looping from rack to rack shall not be done.

#### 10.7.4 Earthing of outdoor installations

- 10.7.4.1 An earthing system shall be designed to ensure personnel safety and protection of installations against damage.
- 10.7.4.2 To achieve the primary goal of assuring personnel safety and damage control, a low impedance path shall be made available to the current generated due to lightning or power system fault. The potential differences between any two points shall be as low as possible. Safety considerations also require the chassis or enclosure to be earthed to minimise shock hazards to system staff.
- 10.7.4.3 To achieve the secondary goal of providing protection for sensitive and interconnected electronic and electrical systems, earthing shall be designed to minimise the noise voltage generated by currents from two or more circuits flowing through a common earth impedance and to avoid creating earth loops susceptible to magnetic fields and differences in earth potential.

- 10.7.4.4 All outdoor installations listed below but not limited to, shall be earthed to the nearest Main earth bus bar with a minimum 16 mm<sup>2</sup> copper conductor:
- (1) metallic sheath & armoury of all cables at regular intervals;
  - (2) location boxes;
  - (3) racks;
  - ;
  - (4) any other TPWS installation as may be necessary to cover complete scope of works defined in the Contract.
- 10.7.4.5 a) EM P-4/EM P-16 Contractors shall develop Project wide Earthing and Bonding Management Plan. ST P-5A Contractor shall coordinate and provide earthing system accordingly as per International practice.
- b) Extension of Traction Earth from the agreed track side connection point to TPWS equipment shall be done by ST P-5A Contractor as per agreed system of Earthing Management Plan.
- c) EMP-4/EM P-16 Contractor shall be connecting OHE masts and rails to Traction Earth.
- 10.7.4.6 NOT USED
- 10.7.4.7 Any earth provided by the Contractor shall be maintenance free and maintain its maximum earth resistance value of 1 Ohm for a minimum period of 5 years.
- 10.7.4.8 The metallic sheath and armoury of all cables shall be earthed as per the established practices in RE areas of the Indian Railways.

## 10.8 Lightning and surge protection

### 10.8.1 General

- 10.8.1.1 While the station buildings will be provided with the lightning protection arrangements by other project contractors, the protection against lightning surges travelling through conductors into equipment shall be provided by P5A contractor using appropriate devices.
- 10.8.1.2 Purpose of lightning and surge protection provision is to eliminate failures of Solid state electronic equipment due to high voltage transients and lightning.
- 10.8.1.3 Requirements of effective lightning and surge protection:
- 10.8.1.3.1 It shall be complying with IEC 62305.
  - 10.8.1.3.2 Device lifetime shall not be less than that of the system for which it affords protection.

- 10.8.1.3.3 All TPWS equipment shall be fully protected against damage from voltage surges or spikes which may appear in any part of the power supply or circuit as a result of power supply switching or lightning.
- 10.8.1.3.4 Surge protective devices shall be provided by P-5/P-17 Contractors at the inputs and output of the PSS to protect the PSS and the load equipment against any power surge due to lightning, switching, etc.
- 10.8.1.3.5 Surge arrestors shall be provided at both the incoming cable termination and the incoming power supply switches inside the SER to suppress any incoming voltage surge or spike.
- 10.8.1.3.6 All surge protection equipment shall be grouped together in close proximity to the main earth bus bar and be physically and electrically isolated from other TPWS equipment. External cables shall enter the equipment room or apparatus box as close to the main earth bus and surge protection equipment as possible and as far as possible from the internal wiring.

## **10.9 Housing, Enclosure and Cabinet**

- 10.9.1 All equipment installed shall be able to withstand vibration levels likely to be experienced in railway stations & along railway track side structures.
- 10.9.2 All design of housing and enclosure shall be submitted to the Engineer for review.
- 10.9.3 Unless specified otherwise, all equipment to be housed in outdoor environment (open areas, etc.) shall be dust proof and water proof to IP 65 standard enclosures as a minimum. Open areas shall be the areas within reach of direct sunlight and rain.
- 10.9.4 All equipment cabinets shall be manufactured from mild steel sheet of thickness at least 1.6mm and shall have treatment for corrosion protection. The cabinet shall not be higher than 2200mm.
- 10.9.5 All cabinets installed in equipment rooms with false floor shall have cable entry at the bottom.
- 10.9.6 For floor mounted type cabinets, access to cabinets and sub-assemblies within cabinets shall be provided via removable front and/or rear doors equipped with locking facilities. Side panels shall be removable, if necessary.
- 10.9.7 Particular attention shall be paid to the ventilation of cabinets to ensure an acceptable condition for equipment inside. The Contractor shall submit, for the review of the Engineer, calculations proving that the temperature inside the equipment cabinet can be maintained within the temperature specifications of the equipment.
- 10.9.8 The layout of equipment shall be designed to provide easy access to every individual part from the outside.

\* \* \* End of Chapter 10\* \* \*

## 11. PACKAGING, SHIPPING, STORAGE AND DELIVERY

### 11.1 Packaging

#### 11.1.1 General

- 11.1.1.1 The requirements on packaging, shipping, storage and delivery shall be as given in the GS.

#### 11.1.2 Cable Drums

- 11.1.2.1 Immediately after the tests at the place of manufacturing, both ends of every length of cables shall be sealed by enclosing them with approved caps, tight fitting and adequately secured to prevent ingress of moisture.
- 11.1.2.2 The ends of the factory lengths of cable shall be marked "A" and "Z", "A" being the end at which the sequence of core numbers is clockwise and "Z" the end at which the sequence is anti-clockwise.
- 11.1.2.3 The end which is left projecting from the drum shall be consistently "A" or "Z", and shall be protected against damage in such a manner that the enclosure cannot be easily removed during handling while in transit.
- 11.1.2.4 Cables shall be supplied on drums in the longest possible lengths and within practical limits. The drum width when mounted on the rail vehicle shall not exceed the specified Gauge of the railway.
- 11.1.2.5 The maximum allowable diameter of cable drum shall be 2000mm. The use of cable drums with diameter in excess of 2000mm shall be subject to the review of the Engineer.
- 11.1.2.6 All cable drums shall be designed to be securely mounted on the rail vehicle with the mounting accessories provided by the Contractor for cable laying along trackside.
- 11.1.2.7 The drums shall also be designed for use in conjunction with any special cable-laying equipment and accessories complete with spindles and cable drum braking gear, which shall be used to install the cables on Site.
- 11.1.2.8 Each drum shall bear a distinguishing number and label "WDFC TPWS System", either printed or neatly chiselled on the outside of one flange.
- 11.1.2.9 Particulars of the cable, i.e. voltage, length, conductor size, number of cores, finish, section and length number, gross and net weights, shall be clearly shown on one flange of the drum. In addition, the words "Running End 'A'" or "Running End 'Z'" as appropriate shall be marked on the flange and the direction for rolling shall be indicated by an arrow.

### 11.2 Storage

- 11.2.1 The Contractor shall provide his own storage and facilities at his premises for storage of all items to be provided for this Contract before delivery to the Site for installation.
- 11.2.2 The Contractor shall maintain record of stored items for this Contract and make available to the Engineer for inspection upon request.

### **11.3 Delivery**

- 11.3.1 The Contractor shall deliver all items supplied under this Contract to the Site as desired by the Engineer.
- 11.3.2 The Contractor shall include the delivery activities in his three month rolling programme and five week rolling programme to draw the Engineer's attention.
- 11.3.3 The Contractor shall ensure the Site is ready and in good conditions for delivery.
- 11.3.4 The Contractor shall ensure good conditions and security of the delivered items on Site.
- 11.3.5 The Contractor shall remove temporary fittings, if necessary, for delivery of his items to site and shall restore the fittings to the original state and to the satisfaction of the Engineer.
- 11.3.6 No dangerous goods shall be delivered to the Site.

\* \* \* End of Chapter 11\* \* \*

## 12. DOCUMENTATION

### 12.1 General

- (1) Operation and Maintenance Documentation is mentioned in GS in general. This chapter mentions particular requirements for TPWS System.
- (2) The Contractor shall submit a submission programme. The submission program shall identify all submissions to be furnished, submission titles, submission numbers and target submission dates.
- (3) The Contractor shall provide configuration management to ensure that the system is correctly configured. The Contractor shall ensure that a configuration control program is maintained. The programme shall ensure that the configuration of each item is recorded and maintained during the life of the Contract including Defect Liability Period.
- (4) The Contractor shall submit a Project Management Plan to the Engineer for review. The Project Management Plan shall identify the persons to be responsible and the methods and arrangement to carry out the Project Management.
- (5) Only Track Layout plans shall be supplied by the Civil Contractors. All other drawings and documents shall be prepared by the Contractor.
- (6) Symbols used in drawings shall be same as in use in Indian Railways.
- (7) All documents shall be submitted for review and approval by the Engineer.
- (8) OEM Manuals: All manuals/ Driver software CD's etc., whatever comes with the equipment purchased from vendors shall be handed over to DFCCIL.
- (9) Warranty Certificates of OEMs: All Original Warranty Certificates of OEMs shall be registered in the name of DFCCIL. These warranty certificates received from the OEMs shall be passed on to DFCCIL.

### 12.2 List of Drawings

12.2.1 The drawings to be supplied by the Contractor shall be, but not limited to, the following:

- (1) Preliminary Design
  - a) TPWS details in Signalling Plan (To scale and supplied by P5/P17 Contractors);
  - b) Power Supply Diagram for stations including Location Boxes (To include maximum current on every cable & thus deduce cable size);
  - c) Power Supply Diagram for Auto Location Huts including Location Boxes;
  - d) Power Supply Diagram for Interlocked LC Gates including Location Boxes (away from Auto location hut);

- (2) Detailed Design
  - a) Cable Core Chart;
  - b) Cable Route Plan (Separate for all stations & blocks sections);
  - c) Power supply Load Calculation for Junction & Crossing stations;
  - d) Power supply Load Calculation for Auto Location Huts;
  - e) Power supply Load Calculation for Interlocked LC Gates (away from Auto location hut);
  - f) Interface documents with other contractors;
  - g) Circuit Diagrams;
  - h) TPWS details in Station Working Rule Diagrams (supplied by P5/P17 Contractors);
  - i) Equipment Rack details;
  - j) Cable Termination Rack Diagram;
  - k) Fuse Details;
  - l) TPWS details in Relay contact analysis (supplied by P5/P17 Contractors);
  - m) Cable termination details of Location/ Junction boxes.
- (3) Equipment Layout Plans (including Cable troughs wherever required)
  - a) Signal Equipment rooms;
  - b) PSS rooms;
  - c) ASM office;
  - d) Auto Location Huts;
  - e) Location/ Junction boxes;
  - f) Table of clearances as per SOD for trackside equipment.
- (4) O&M Manuals
- (5) As built drawings
  - a) For items under (1), (2) and (3) above and
  - b) Bill of quantity of equipment on location basis.

### **12.3 Submission requirements**

- (1) The Contractor shall include records of amendment in each submission with the following details:
  - a) Revision history and status of the submissions;
  - b) Description on changes for each revision;
  - c) The names & signatures of Contractor's designer, reviewer and approver for authorisation of the submission indicating proper design check has been carried out before submitting to the Engineer.



- (2) The revision status and date of preparation of the submission shall be clearly indicated at the header of each page of the submission.
- (3) The first submission shall be version A and subsequent revisions shall be version B, then version C, so on and so forth until document is approved by Engineer. First approved version shall be version 0 and subsequent revisions shall be version 1, then version 2, so on and so forth.
- (4) The Contractor shall maintain record of the submissions and updated records shall be included in the Monthly Progress Report. The submission records shall include the following details:
  - a) Submission number;
  - b) Submission title;
  - c) Revision history;
  - d) Status of Engineer's response for each revision;
  - e) Submission dates and dates of return from the Engineer for each revision;
  - f) Current status.

#### **12.4 Levels of submission**

- (1) The Contractor shall adopt top-down approach and submit submissions of the following levels in a logical sequence for review by the Engineer:
  - a) System level related submissions;
  - b) Equipment level related submissions;
  - c) Installation design related submissions;
  - d) Design calculations;
  - e) Management plans and procedures;
  - f) Approval certificates;
  - g) Miscellaneous submissions.
- (2) System level related submissions shall show the total system including the configuration block diagrams, operating principle, system features and functions, capacity, expandability, interconnection within the subsystem, between subsystems and between other Contract Packages.
- (3) Equipment level related submissions shall show the specification on electrical, mechanical and functionality of the equipment/materials employed for the system and the subsystems.
- (4) Installation design related submissions shall include:
  - a) The installation methods and procedures for different types of installation activities;
  - b) Drawings showing the equipment locations and positions, subsystems coverage;

- c) Schematic and wiring diagrams;
  - d) Cable core chart and numbering scheme;
  - e) Equipment mounting details;
  - f) Configuration data, parameters and settings;
  - g) Cable route drawings;
  - h) Layouts in equipment racks, in equipment rooms, trackside and all other equipment locations.
- (5) Design calculations shall demonstrate the performance of the system and subsystems.
- (6) The Contractor shall submit a copy of certificates from relevant parties and authorities as required including equipment calibration certificates from manufacturers and laboratories.

### **12.5 As-built documentation**

The as-built documentation shall describe the system as installed and provide sufficient information for users, maintainers and developers to execute their responsibilities.

\* \* \* End of Chapter 12 \* \* \*

## 13. OPERATION AND MAINTENANCE SUPPORT

### 13.1 General

- (1) Operation and maintenance support is mentioned in GS in general. This chapter mentions particular requirements for TPWS System.
- (2) The Contractor shall investigate all failures, major failures, repetitive failures, installation and design defects and take all necessary corrective actions throughout the Contract period.
- (3) The Contractor shall investigate interference problems either from or to the systems of other Contract packages and take all necessary corrective actions throughout the Contract period.

### 13.2 Operation and Maintenance Document

The Operation and Maintenance Plan shall be prepared by the Contractor and submitted to the Engineer for review not later than six (6) months after the award of the Contract.

### 13.3 Operation and Maintenance Plan

- (1) The Maintenance Plan shall describe the Contractor's proposed maintenance regime for preventive and corrective maintenance of the system, including, but not limited to the following:
  - a) Maintenance philosophy and approach;
  - b) All necessary tasks for first line, second line, third line and corrective maintenance;
  - c) Frequency of each maintenance task.
- (2) The Contractor shall include the following information on each maintenance task described in the Maintenance Plan:
  - a) The equipment, sub-systems covered in the task;
  - b) Step by step procedure to carry out the task;
  - c) Tools and test equipment required for each task;
  - d) Diagrams and flowcharts by illustration, if applicable;
  - e) Adjustment procedures for all field adjustable units;
  - f) Recovery procedures, if applicable;
  - g) Precautions to be followed by maintenance personnel;
  - h) Estimated duration and manpower required.
- (3) In addition to the Maintenance Plan, the Contractor shall also submit a Yearly Routine Maintenance Schedule to the Engineer for review and shall indicate the schedule of maintenance tasks in a calendar year.
- (4) The Maintenance Plan shall be aligned with DFCCIL's maintenance policy.

## **13.4 Software Support**

### **13.4.1 General**

- (1) Software support is mentioned in GS in general. This chapter mentions particular requirements for TPWS System.
- (2) The Contractor shall provide all changes, debugging, updates, modifications and upgrade of all the software developed or delivered for the system including data configuration tables free of cost if such changes are necessary and in order to maintain the normal operation and meet the requirements given in this Particular Specification.
- (3) Software updates shall be provided as and when becoming available till expiry of Defects Notifications Period..
- (4) The changes and modifications of the software shall not degrade the performance or have adverse impact on the system.
- (5) The Contractor shall maintain backup copies of all software developed or delivered for the System.
- (6) The Contractor shall ensure that all new versions are fully tested and validated and reviewed without objection by the Engineer prior to loading into the system.
- (7) The Contractor shall provide training for the Employer's staff for use of new version, as and when incorporated.

### **13.4.2 Security obligations**

Within fourteen (14) days of the installation of any software, which is developed or modified for this Contract, into the permanent works by the Contractor, the Contractor shall submit to the Engineer for retention by the Employer two (2) backup copies of the software, which shall include, without limitation:

- a) All executable code including all data configuration tables;
- b) All design documentation relating to the software;
- c) Any specified development tools required for maintenance of the software, including, but not limited to, editors, compilers and linkers.

## **13.5 Support during Defects Liability Period**

### **13.5.1 General**

- (1) Support during Defect Liability Period is mentioned in GS in general. This chapter mentions particular requirements for TPWS System.
- (2) During the first three months of Defect Liability Period, the Contractor shall provide necessary guidance to O&M staff in routine maintenance so that staff is able to carry out this activity independently as per training imparted for the same.

- (3) The Contractor shall provide workshop repair services of all defective and faulty items of the system.
- (4) The Contractor shall provide support and call-out services to the Employer as required for restoration of the System to normal operation in case any faults or defects are found.
- (5) The Contractor shall submit a maintenance manpower plan showing the Contractor's organization and committed resources level available for all types of activities to be carried out within the Defect Liability Period.
- (6) The Contractor shall ensure that all his staff who provide maintenance support are competent and have sufficient training in the sub-system for which they are responsible.

#### 13.5.2 Workshop Repair

- (1) The Contractor shall collect and repair defective parts that are removed from the system during maintenance or from the Engineer.
- (2) The Contractor shall perform all necessary adjustments or alignments to the repaired parts. The repair of defective parts can only be considered as completed and returned to stock or back to the system if the parts are tested and verified fit for use in the system.
- (3) The Contractor shall use only components equal to or of higher specification than the original components in his repair activities.
- (4) The performance of the defective parts after repair shall not be degraded or deteriorated due to repairing.
- (5) The maximum turnaround time for workshop repair shall be less than twenty eight (28) days. The turnaround time shall start to count when the defective parts are removed from the system and end when the parts are repaired and returned to stock or the system. Any extension of workshop repair time shall be got agreed by the Engineer.

#### 13.5.3 Support and call-out services

- (1) The support and call-out services shall be available 24 hours per day and 7 days per week.
- (2) The Contractor shall provide sufficient number of competent and experienced staff for the support and call-out services.
- (3) The Contractor shall provide a list of maintenance staff together with the contact landline/mobile telephone numbers who can be contacted for support and call-out services.
- (4) Any changes in the call-out numbers and the maintenance staff shall be notified to the Engineer at least two weeks before such changes become effective.

- (5) The Contractor’s staff shall reach the site for maintenance support within one hour upon receiving the call-out request from the Engineer and shall proceed to perform corrective actions to restore the system to full normal operation.
- (6) The Contractor shall take every precaution to protect existing equipment from damage and make good any damage caused.

#### 13.5.4 Monthly Maintenance Meeting

The Contractor shall attend the Monthly Maintenance Meeting with the Engineer to discuss the maintenance matters during the Defect Liability Period. The dates and agenda of the meeting shall be agreed with the Engineer.

### 13.6 Spares, Special Tools, Diagnostic equipment and Test Equipment

#### 13.6.1 Spares

- (1) Spares, Special Tools, Diagnostic equipment and Test Equipment are mentioned in GS in general. This chapter mentions particular requirements for TPWS System.
- (2) The Contractor shall provide his own spares during installation and commissioning period as well as for support during the Defects Liability Period. The Contractor shall also provide separate spares for the Employer to enable the Employer to operate and maintain the system.
- (3) Recommended spares shall not be less than the scale given below:

S. No.	Item	Unit	Quantity
1.	Underground Cables.	Km	5% of the total cable laid subject to a minimum of 1 km of each type.
2.	All other cable & wires.	m	5% of the total cable/ wire used laid subject to a minimum of 100 meter of each type.
3.	Power supply cards/ modules (equipment power supply cards/ modules including PSS) complete with interconnecting cables and connectors.	Nos.	20% of each type installed.
4.	All other electronic cards/ modules complete with interconnecting cables and connectors.	Nos.	10% of each type installed.
5.	All rail mounted equipment complete with interconnecting	Nos.	20% of each type installed.

	cables and connectors.		
6.	MCB, surge protection device, fuses & terminals.	Nos.	10% of each type installed.
7.	Mechanical signalling items (except bare racks and cabinets).	Nos.	5% of each type installed.
8.	All other equipment.	Nos.	10% of each type installed.
9.	All other interconnecting cables/ connectors not included in 1 & 7 above.	Nos.	10% of each type installed.

- (4) The Contractor shall submit the list of contract (maintenance) spares within six (6) months after the Commencement Date of the works to the Engineer for review. The list shall include:
  - a) Grouping by subsystem, diagnostic and test equipment and special tools, as applicable, for stocking identification;
  - b) A cross-reference and indexing system for replacement components common to more than one subsystem;
  - c) Detailed description with references and correlation with the maintenance manuals;
  - d) Contractor’s own spares.
- (5) The Contractor shall keep and maintain sufficient stock of his own Commissioning Spares and Defects Liability Spares. In addition, in determining the list of spare parts for the Commissioning Spares and Defects Liability Spares, the Contractor shall provide calculation to support the proposed types and quantities with the following taken into account:
  - a) The expected failure rate of the parts;
  - b) Population of the parts in the system;
  - c) Criticality of the parts in the system;
  - d) Availability and MTBF figures of the system;
  - e) Spare delivery lead time;
  - f) Workshop repair turnaround time.
- (6) The Contractor shall submit the list of Commissioning Spares, with the types and quantities of spares the Contractor intends to hold, at least three (3) months before the commencement of the installation activity to the Engineer for review.
- (7) The Contractor shall submit the list of Defects Liability Spares, with the types and quantities of spares the Contractor intends to hold, at least three (3) months before the commencement of the Defects Liability Period to the Engineer for review.

- (8) The Contractor shall include details of the stock of the Contractor's own spares in the Monthly Progress Report. The status of the spares, either in store or under workshop repair, shall also be included.

13.6.2 Contract spares for Employer's operational and maintenance requirement:

- (1) The Contract spares shall include, but not limited to, spare modules, sub-assemblies, special components and fuses.
- (2) The Contractor shall submit quantities of each type of spare modules, sub-assemblies and parts and those recommended by him.
- (3) The shelf life of the equipment shall also be mentioned by the Contractor.
- (4) Any item not included as spare in the offer and subsequently found to be necessary during Defect Liability Period or during Maintenance contract period (if any) shall be supplied by the successful tenderer FREE OF COST.

13.6.3 Special Tools, Diagnostic equipment and test equipment:

- (1) The Contractor shall provide the Special Tools, Diagnostic equipment and test equipment.
- (2) The Contractor shall submit quantities of each type of Special Tools, Diagnostic equipment and test equipment and those recommended by him. The quantities shall be equal to number of IMDs + Sub Depots increased by 20%.

\* \* \* End of Chapter 13 \* \* \*



## 14. TRAINING

### 14.1 General

- (1) Requirements for Training are mentioned in GS in general. This chapter mentions particular requirements for TPWS System.
- (2) Training support shall be referred to in section 1.3 and as follows.

### 14.2 Scope of Training

- (1) The objectives of this training are as under:
  - (a) to enable the Employer's maintenance personnel to maintain the commissioned TPWS system and
  - (b) to enable the Employer's Key Instructors to be competent to deliver future courses for other employees of the Employer.
- (2) The training shall be imparted on various sub-systems. Aspects covered shall include, but not be limited to, the following:
  - (a) Operating features and functional principles of the relevant sub-systems;
  - (b) System engineering aspects including but not limited to design standards, design criteria and parameters, short-circuit and other calculations, insulation and protection co-ordination;
  - (c) Details of major equipment and components used in the System;
  - (d) System operating and maintenance management procedures and
  - (e) Control and monitoring systems for each sub-systems.
- (3) The training shall be in India and abroad including training at manufacturing facilities as appropriate.

### 14.3 General Requirements

- (1) This section of the specification covers the requirements for a Training Programme to train the Employer's maintenance, operating and training personnel. The Training Programme shall enable the basic staff to operate, service, enhance, maintain and interact with the hardware, software and firmware such that the systems and associated equipment will perform in accordance with the specifications of this contract.
- (2) The Contractor shall provide comprehensive training to the Employer's maintenance, operating personnel and Key Instructors.
- (3) The Contractor shall provide training rooms, competent training instructors, training manuals, all necessary aids and materials in support of all training courses. In addition to supply of printed manuals to all trainees, the training manuals shall be submitted in original plus ten (10) hard copies and in electronic format to the Engineer.

- (4) The training instructors shall be qualified and competent with sufficient years of practical experience in the relevant fields and possess good communication skills. The training instructors shall be competent staff of the Contractor, the subcontractors or the equipment manufacturers.
- (5) Training in India or abroad shall be conducted in English Language. The respective training manuals will be provided in English. If asked by the Engineer, the training manuals will be provided in Hindi also.
- (6) Should, in the opinion of the Engineer and due to good reasons, any of the Contractor's training instructors not be considered competent or not to have a suitable attitude or aptitude for carrying out the training courses for whatever reason, the Contractor shall remove the said person and replace him as soon as possible with an acceptable substitute.
- (7) The training shall be carried out at such locations where the greatest benefit for trainees may be gained. This may be in India, abroad, at place of manufacture, assembly or testing or at such other locations as may be necessary. All places of training shall be subject to be proposed by the Contractor and approved by the Engineer.
- (8) The training courses and/or sessions shall include system performance requirements and all major equipment and works engineered by the Contractor.
- (9) The Contractor shall provide full-time on-Site management, co-ordination and supervision of the entire training programme to ensure the continuity of classes and proper distribution of training materials and be responsible for interfacing with the instructors.
- (10) The Contractor shall be required to arrange technology transfer and training to the Employer's staff in respect of design, installation, testing and commissioning of the System and each subsystem to enable them to work as trainers. The Employer will nominate up to three (3) persons for each subsystem for this training.
- (11) The Contractor shall submit assessment reports on the performance of individual trainees to the Engineer. Training evaluation shall be required at regular intervals to monitor the progress and suitability of the training programme. Items that require further information or tasks that require additional training or practice will be discussed between the Engineer and the Contractor at the evaluation meetings. Such items or tasks must be appended to the training programme as soon as possible.
- (12) Throughout training programme, the Engineer shall have free access to all training sessions to monitor the progress of the trainees and the Contractor's training instructors.
- (13) If required by the Engineer, any one or more of training courses may be repeated during currency of the contract to train additional batches of staff.

#### **14.4 Training Plan**

- 14.4.1 The Training Plan shall be prepared by the Contractor and submitted to the Engineer for review not later than six (6) months after the award of the Contract.
- 14.4.2 The Training Plan shall include, but not be limited to, the following:
- (1) the program of the training courses and submission schedule of the training materials;
  - (2) overview and description of objectives of each training course;
  - (3) the location where the training courses to be conducted;
  - (4) set ups for practical exercises;
  - (5) the Contractor's training organisation chart, including the role and responsibilities of individual key persons;
  - (6) the qualifications and experience of the training instructors; and
  - (7) details of training simulators to be provided or developed, if applicable.

#### **14.5 Training Courses**

- (1) The Contractor shall provide Training Courses on all facilities, systems, equipment, hardware, firmware and software. Each Course shall be specific and shall consist of classroom, hands-on and/or field training as necessary to accomplish the Course Objectives specified in the Training Program Plan. The Contractor shall develop detailed training modules based on information in the Operating and Maintenance manuals.
- (2) The technical training courses to the Employer's staff shall be programmed in phase with the progress of manufacture and installation to ensure that trainees are present during all stages of the manufacture, installation and commissioning of the equipment which is the subject of the training. The Contractor shall ensure that the courses fully encompass all aspects of the basic design, manufacture, installation, commissioning and maintenance of the Equipment with maximum effort being directed at instructions in the maintenance of the installations.
- (3) The Contractor shall provide training courses for each of the sub-systems of TPWS.
- (4) The Employer's Key Instructors shall attend all types of training courses so that they shall be able to subsequently train the Employer's staff in future in all aspects of operation and maintenance of the System.

#### **14.6 Operating Staff Courses**

- (1) The operating staff training courses shall be developed to provide all necessary knowledge and skills for operating staff of the Employer to operate the system under normal, degraded and emergency situations and recovery from minor or simple faults. In particular, the training courses shall include the following as minimum:

- a) Overview of the relevant System;
  - b) Description of the operation principle of the System and Subsystems;
  - c) Description for operating technical equipment;
  - d) Operational features and functions;
  - e) Familiarization and use of all man-machine interfaces involved;
  - f) Reading and interpretation of system status and alarm messages or indications;
  - g) Normal and degraded operating procedures;
  - h) Operating procedures under emergency situations;
  - i) Procedures for recovery from minor or simple faults;
  - j) Use of Operator's Manuals and documentation;
  - k) Detailed knowledge and correct application of operating rules and procedures;
  - l) Local knowledge of stations and the line.
- (2) Particular exercises shall be included in the operating training course for each trainee to operate and manage the system under normal and emergency operating conditions and simple fault recovery.

#### **14.7 Maintenance Staff Courses**

- (1) The maintenance staff courses shall be developed to provide all necessary knowledge and skills:
  - a) To perform full maintenance, including both preventive and corrective maintenance on each sub-system and
  - b) To perform system Engineering management including system parameter configuration, enhancement, adjustments and provision of new equipment and components.
- (2) Training shall be provided on all aspects of Maintenance of the System including proprietary or third party equipment and software. Software shall also cover custom-designed software or software driven utilities to form part of the Preventive and Corrective Maintenance Procedures.
- (3) Level& Types of Maintenance
  - a) Preventive maintenance means routine or scheduled maintenance requirements that must be performed on the system (including overhaul) to ensure that the operation of the system is maintained.
  - b) Corrective maintenance means unscheduled troubleshooting maintenance requirements that must be performed on the system so that the system can be returned to normal service as soon as possible.
  - c) First level maintenance means corrective maintenance procedures that must be performed on site so that the system can be restored back to normal service as soon as possible.

- d) Second level maintenance means corrective maintenance procedures that are implemented at workshop level to restore individual components and parts back to normal operation as soon as possible.
- (4) Training shall be based upon a 'two-stage' concept as follows:
- a) Stage one shall consist of training on the basic concepts and principles. These shall include system configuration, system specification, system operation & control, preventive maintenance procedures, troubleshooting/repair concepts, interpreting diagnostic test reports and equipment or system test & restoration.
  - b) Stage two shall consist of on-the-job training on Preventive and Corrective Maintenance.
- (5) The Contractor shall determine the contents of the courses and the courses shall include the following as minimum:
- a) Overview of the relevant System;
  - b) System features and functions;
  - c) Operating principles;
  - d) Safety precautions to be taken;
  - e) Description of system components;
  - f) Test and commissioning procedures;
  - g) Use of Diagnostic equipment, test equipment and special tools;
  - h) Reading and interpretation of alarms, indications, messages and print-outs;
  - i) Preventive maintenance procedures;
  - j) Fault diagnosis, troubleshooting and corrective maintenance procedures;
  - k) Equipment settings and parameters configuration;
  - l) Use of equipment manuals, operating and maintenance manuals, circuit diagrams and wiring schematics;
  - m) Methods and procedures to provide new circuits, system expansion and enhancement;
  - n) Data, software backup and loading;
  - o) Use of software such as peripheral control and configuration, utility, database structure, generation and modification.
- (6) Practical exercises shall be provided for each trainee to practice the following as minimum:
- a) Use of diagnostic equipment, test equipment and special tools;
  - b) Preventive maintenance;
  - c) Fault diagnosis and troubleshooting with induced faults set by the instructor to simulate real-life situation;
  - d) Faulty modules or cards replacement and restoring the system to normal operation;

e) Installation and Commissioning of sub-systems/system.

#### **14.8 Training Materials**

- (1) Training Aids, Training Materials and Training Devices shall be of durable construction and shall become property of the Employer on completion of Training.
- (2) The Contractor shall provide all Training Aids, Training Materials, Training Devices, Special Tools, Diagnostic equipment and measuring instruments, fixtures, models, or other equipment required to train the Employer's maintenance staff and Instructors.
- (3) The Contractor shall prepare Training Manuals and submit them to the Engineer for review at least 90 days prior to the start of the Training Demonstration.
- (4) Throughout the Contract, it shall be the responsibility of the Contractor to supply all changes and revisions of the Training Manuals to the Engineer.
- (5) Training Manuals shall become the property of the Employer.
- (6) The Employer reserves the right to copy all Training Materials for use in Training Courses.
- (7) All the training materials shall be accurate and match with the actual design of the System.

#### **14.9 Training Records**

- (1) The Contractor shall keep attendance records of trainees. The Contractor shall devise a system and standards in assessing the level of knowledge, understanding of the course content and proficiency of the trainees. The system and standards shall be submitted to the Engineer for review at least four weeks before commencement of the training course.
- (2) The Contractor shall issue appropriate training certificate to the trainees who pass the assessment.

#### **14.10 Course Evaluation**

- 14.10.1 The Contractor shall develop questionnaires to trainees for each training course in determining the level of satisfaction with the course content. Appropriate scoring weightage shall be assigned to each question in the questionnaires such that the scores shall reflect the trainee's satisfaction to the training course. The questionnaires shall be submitted to the Engineer for review four weeks before the commencement of the training course.
- 14.10.2 Upon completion of each training course, the Contractor shall distribute the questionnaires to the trainees to fill in.

- 14.10.3 The Contractor shall submit a training report to the Engineer for review within two weeks after completion of each course. The training report shall include a summary of the training course conducted, the results of trainees' assessment and the course evaluation questionnaires.
- 14.10.4 The Contractor shall submit the course evaluation criteria to the Engineer for approval.

\* \* \* End of Chapter 14\* \* \*

## **Annexure 1: Train Monitoring & Diagnostic System – Functional Requirement Specification**

### **1. SCOPE**

**Details given below pertain to TMS to be provided by P5 Contractor in Rewari-Vadodadra section (Phase 1) of DFCCIL Western corridor. Similar details pertain to TMS to be provided by P17 Contractor in JNPT-Vadodadra section (Phase 2) of DFCCIL Western corridor.**

- 1.1 Train Monitoring & Diagnostic System (TMS) is proposed to be provided in Rewari-Vadodadra section (Phase 1) of DFCCIL Western corridor.
- 1.2 TMS shall be designed to include complete Signalling system covering full line of Phase 1. If required, TMS shall be commissioned in two or more phases depending on progress of works.
- 1.3 Wall display shall include display of SCADA also. Provision of SCADA will be done by P-4 contractor and he will provide feed for display controller.
- 1.4 Backup Control Centre (BCC) shall be provided by another Contractor.

### **2. TMS SYSTEM ARCHITECTURE**

- (i) System shall have highly scalable architecture. It shall be possible to increase/reduce the number of monitored equipment flexibly by adding/reducing the number of servers.
- (ii) There will be redundancy in servers with Main and Standby configuration. Both Main and Standby servers will be normally ON and updated with latest data/status.
- (iii) Normally system will be working from main server. In case of its failure, standby will take over automatically and generate an alarm.
- (iv) It shall be possible to change the system load manually from Main to Standby and vice versa.
- (v) Provision shall be made for automatic transfer as well as forced takeover between Main OCC & BCC. Refer Annexure 7-5 for details.

### **3. SYSTEM RESPONSE TIME**

The system shall be so designed so as to achieve the overall objective of providing real time information related to train operation in section proposed to be covered by TMS. The following response time shall be considered in design:

- i) The response time between a change of state at a wayside station and its display at OCC shall not be greater than 2 seconds.
- ii) The time taken between initiation of a query relating to data /result /report and its response on terminals shall be as small as possible.

### **4. AGGREGATION OF INFORMATION**



The status and alarms of all Signalling equipment of Block sections will be sub divided into two halves and sent from Auto Locations to nearest station. At the station, this data will be added to similar data emanating from station equipment and sent to OCC through LAN on OFC. Contents of two halves shall be got agreed by the Engineer.

## 5.LIVE INDICATIONS

### 5.1 Live Indications in Control Office (On Overview Mimic Indication Panel):

- i. Overview Mimic Indication Panel consisting of video panels shall be provided to display an overview of the DFCCIL Western Corridor Phase 1 network covered by TMS. Black background shall be used for getting proper contrast. Other colours used shall be such as to give bright and easily distinguishable display.
- ii. The Mimic Indication Panel shall display all Axle Counter Track sectioned lines and all interlocked signal aspects of track layouts of stations & auto sections from Rewari to Vadodara stations. Location of Auto Location Huts shall also be shown.
- iii. The Overview Mimic Indication Panel unit shall display important indications of wayside stations panel, aspects of auto signals, status of auto section's Axle Counter Track sections and LC gates etc. The panel will also provide alarm indications of failure of points, signals, Axle Counter Track sections etc. as the case may be. Less significant objects/indications like non Axle Counter Track sectioned sidings etc. will be shown with a thick line of suitable colour on the overview panel.
- iv. Vacant/ occupied status of both Main and supervisory Track Vacancy Detection Systems shall be displayed side by side. While main track layout shall show status of main detection system, status of supervisory detection system may be shown by small strips by side of main track. The proposed arrangement shall be got approved by the Engineer.
- v. The Overview Mimic Indication Panel unit shall display the occupancy of various track sections along with the train description. Train ID box shall indicate different colours for different type of loads e.g. Container, Petroleum products, Food grains etc. In case train number is not keyed-in, the same shall be shown as flashing unknown train identifier mark along with Non Described Alarm (NDA). Alarm will stop as soon as the train number is keyed in by the controller / ASM.
- vi. If a train has stopped at any place enroute for more than the prescribed time, an alarm shall be raised to draw attention of the controller.
- vii. It shall be possible to update changes in yard layout through software from the maintenance terminals without any requirement of change in the hardware. The uploading time of software changes shall be minimum and it shall be possible without complete shutdown of the indication system.
- viii. It shall be possible to show the temporary speed restriction by showing the Tag box or by any other means.

- ix. Text in Mimic Indication panel showing signalling layout and status shall be readable from seats of Chief Controller and all Section Controllers.
- x. Text in Mimic Indication panel showing SCADA shall be readable from seats of Chief Controller and all Traction Power Controllers.

#### 5.2 Live Indications to Train Controller Terminals

- i. Section controller / Chief controller terminals (work stations) will consist of 3 monitors each of size of 21"/54 cm. All the features available on Mimic panel shall also be available on these terminals.
- ii. All terminals shall be able to display complete information of yards covered by TMS with details of Axle Counter Track sections, signals, Points, LC gates etc. Any failure of signalling system at any station shall be available in audio & visual form to draw attention of controller. It shall be possible to acknowledge and stop the audio alarm of failures.
- iii. Vacant/ occupied status of both Main and supervisory Track Vacancy Detection Systems shall be displayed side by side. While main track layout shall show status of main detection system, status of supervisory detection system may be shown by small strips by side of main track. The proposed arrangement shall be got approved by the Engineer.
- iv. On line display of train movements shall be available on the terminals with train details such as Train No., type of load, Loco Pilot etc.
- v. Ordinarily it shall show complete yard at a time including all Axle Counter Track sectioned and Non-Axle Counter Track sectioned lines. Big yards can be divided into many parts, with provision of selecting any one part on a screen with facility of scrolling to see the full yard on one /more screens.
- vi. If train identification has not been entered by the train dispatching station, concerned Section Controller shall have facility for entering it on getting NDA.
- vii. It shall be possible to view train graphs. The train graph shall also cover advance charting showing traffic blocks. Train graph lines/Train ID box shall have tag with details of train, crew etc. These features are further described in para 5.3.
- viii. In case of unusual events and delays to trains, system will prompt the controller to enter the reason and other details in the prescribed format.
- ix. The details of occupancy of berthing lines and sidings shall also be available on the terminal.
- x. The crew details available in the system shall also be available on the terminals provided with CHC, Dy. CHC, etc. apart from being available on SCOR & ASM work stations.

- xi. All the traffic and urgent alarms described in para 9.3 shall be available on these terminals.
- xii. Work stations on tables of Traction Power Controllers showing SCADA display shall be provided by P-4 contractor.

#### 5.3 Live Indications On Terminals Provided With Staff at Stations /ELMD / Lobbies etc.

- i. OCC and stations shall be provided with workstation type terminals having capability of graphic display. Remaining other locations, ELMD and lobbies will be provided with industrial Grade PCs.
- ii. ON Line display of train movements (including description) along with layout and status of signalling will be available on workstations as available on section controller's terminals.
- iii. It shall be possible to input TRAIN ID in 8 digits from these terminals along with other information such as destination, type of load, crew details etc. System will generate an audio & video alarm on ASM's terminal as well as in OCC, if train ID has not been filled by concerned Station Master.
- iv. It shall be possible to query the system regarding details of trains, cancellation, rescheduling, delays, diversions etc. either through menu driven commands or through SQL commands.
- v. Details of vehicles stabled on sidings at concerned station shall be displayed.
- vi. Whenever a train leaves / enters the control area or is put out of the system by placing it in the siding or sending it to ELMD, it shall be automatically registered by the system. In addition to this, ASM shall have facility to delete / enter such trains.
- vii. Flashing messages / instructions from the controller and information about expected arrival of next two trains on each line, cancellation and diversion of trains shall be displayed.

#### 5.4 Live Indications to Signal Fault Controller Terminal

- i. Signal fault controller terminal (work station) will consist of 3 monitors each of size of 21"/54 cm. All the features available on Mimic panel shall also be available on this terminal.
- ii. Remote Condition Monitoring of Signalling gears at stations and in Block Sections shall be provided. This shall include logging in of events in central system, generating alarms, alerts and trends about performance / failures of these gears.
- iii. The terminal shall be able to display complete information of yards covered by TMS with details of Axle Counter Track sections, signals, Points, LC gates etc.
- iv. Vacant/ occupied status of both Main and supervisory Track Vacancy Detection Systems shall be displayed side by side. While main track layout shall show status of main detection system, status of supervisory detection system may

be shown by small strips by side of main track. The proposed arrangement shall be got approved by the Engineer.

- v. Following 3 status information of each signalling sub system shall be available on his terminal:
- Serious Failure: Repair required immediately.
  - Minor Failure: Not interrupt failure with which train operation is not effected.
  - Normal status: Information that the equipment is working normally.

Similar information shall be available on various signalling maintenance terminals (for their jurisdictions) provided in OCC, at stations, IMDs etc.

- vi. Any failure alarm of signalling system at any station shall be available in audio & visual form to draw attention of controller. It shall be possible to acknowledge and stop the audio alarm of failures.
- vii. On line display of train movements shall be available on the terminal with train details such as Train No., type of load, Loco Pilot etc.
- viii. Ordinarily it shall show complete yard at a time including all Axle Counter Track sectioned and Non-Axle Counter Track sectioned lines. Big yards can be divided into many parts, with provision of selecting any one part on a screen with facility of scrolling to see the full yard on one /more screens.
- ix. All the traffic and urgent alarms described in para 9.3 of this Annexure shall be available on these terminals.

## 6. TRAIN DESCRIBER SYSTEM

- i. It shall be possible to associate a train with an alpha-numeric ID called a train describer tag.
- ii. A train describer tag shall be unique consisting of up to 8 alphanumeric characters displayed in a text box.
- iii. The train description tag shall track the train in sections monitored by TMS.
- iv. The Train Describer System shall be capable of automatically assigning train describer tags from a train number queue to trains originating at the stations covered by TMS.
- v. The operator viz., SCOR and / or the ASM at entry point shall be able to edit the train describer tag queue.
- vi. The operator viz., SCOR and / or the ASM at entry point shall be able to stop the automatic assigning of train description tag temporarily as mentioned in para iv above.

- vii. The color of the train describer tag box shall be different for different type of train loads e.g. Container, Petroleum products, Food grains etc.
- viii. The Train Describer System shall be able to register in the Software & display following abnormal conditions:
  - a. single Axle Counter Track section failure;
  - b. faulty position of points;
  - c. change in direction of a train;
  - d. division and joining of trains;
  - e. unidentified trains;
  - f. trains passing a signal showing a stop aspect;
  - g. more than one train on the same Axle Counter Track section;
  - h. Wrong marking of object/functions.
- ix. Abnormal disappearing of train describer tag shall generate an alarm and display in different colour.
- x. The Train Describer System shall be able to handle the commands for
  - a. Insertion of a train describer tag on a track or at a signal, which shall be assigned automatically to the train occupying the track;
  - b. Moving a train describer tag to a different location;
  - c. Renaming a train describer tag;
  - d. Exchanging one train describer tag with another train describer tag;
  - e. Deleting a train describer tag.
- xi. It shall be possible to find the location of trains by search command.
- xii. It shall be possible to view list of trains in the Train Describer System with following criteria:
  - a. All trains;
  - b. Only operator identified (known) train;
  - c. Trains in a given direction;
  - d. Trains at or between specific station(s);
  - e. Unidentified or delayed or cancelled trains.
- xiii. The Train Describer System shall send log records of the events logged including the following information to data base:
  - a. Movement of train descriptions (Axle Counter Track section to Axle Counter Track section details with timing);

- b. Operator's commands to the Train Describer System;
- c. System will display crew details from the detailed link available in crew management software on query from various terminals of controllers & lobbies.

## 7. MANAGEMENT INFORMATION SYSTEM

### 7.1 MIS Edit

The system shall allow user to enter any free text tag to be associated with any train.

### 7.2 MIS Reports

- i. The system shall generate report for trains run late by prescribed reference.
- ii. Based on the events logged and the operator input, the system shall generate following (but not limited to) reports:
  - Various Train control charts;
  - Various Punctuality reports;
  - Bad runner report;
  - Train Composition report;
  - Punctuality analysis report in suitable format. This may be daily, weekly or monthly as per prescribed format;
  - Analytical report of various unusual occurrences, i.e. signal failures, OHE breakdown, Loco failure, Sick wagons etc. This can be again generated on daily, weekly or monthly basis on prescribed format;
  - Analytical report of crew link/ utilization;
  - Total Maintenance Blocks granted / refused along with locations, time blocked, time cleared;
  - Sectional running time taken by trains of any ID;
  - Delay report of trains along with train nos., time delayed (at stations/mid-section) etc.;
  - Difference between actual and scheduled running time in tabulated as well as in graphical form.
- iii. The system shall allow user to create an unusual report, describing a failure with the department that it belongs to and the trains that were affected by it.
- iv. The reports shall be generated in designated formats.
- v. Report formats shall be customizable.

- vi. It shall be possible to print generated reports for which 2 nos. of networked A3 Laser colour printers shall be provided.

### 7.3 Train Graph

The train graph, as specified below (but not limited to), shall be made available on the terminals with CHC, Dy. CHC & SCOR:

- i. The system shall plot historical train graph for analysis.
- ii. It shall plot time on X axis and stations on Y axis.
- iii. It shall be possible to show schedule time and the actual time in the same graph but with different colors.
- iv. It shall be possible to show Goods/Special trains in different colors.
- v. It shall be possible to select the direction of train and the line.
- vi. On clicking / selecting a particular train graph, it shall give complete information about the train details viz. train no., crew information, load details e.g. Container, Petroleum products, Food grains etc.
- vii. Advance charting: In case controller defines the Maintenance Block on particular line for particular time, system shall be able to prepare train graph showing advance/predictive movements of available trains in particular section in different colours.
- viii. It shall be possible to deduce average speed of trains between any two stations.

### 7.4 Training Server and Terminals

- i. Separate server and terminals shall be provided for simulation studies & training purpose. The replay of log, time table editing, editing of train graph etc. shall be provided on this terminal.
- ii. It shall be possible to simulate and observe the effect of various parameters such as Speed restrictions, Change in yard layouts etc. on sectional density (capacity) and to produce train graphs in pictorial or tabular form. Simulation of the effect of addition / deletion of a signal shall also be possible. The parameters shall be decided in consultation with DFCCIL.
- iii. Simulation of train movements:- Train movement shall be simulated by occupying & releasing Axle Counter Track sections on sections in accordance with movement of trains.
- iv. The replay of log shall be possible with predefined begin & end time.
- v. The simulator shall work with the same data as the on line system or separate Master data can be kept on the system.

- vi. The simulation shall be possible in real time or in reduced / accelerated time scale.
- vii. The system shall be capable of simulating the existing time-table and compare it with actual running on periodic basis to create Management Information to identify any shortcomings in the system / time-table.

#### 7.5 Crew Management System (CMS)

Crew Management System must be closely integrated with TMS to reap the benefits as indicated in (vi) & (vii) below.

- i. Crew Management System shall be provided for Loco Pilots.
- ii. Crew Management details shall be fed by lobby staff separately for every Loco Pilot. The database will have all the information related to personnel & safety of Loco Pilots.
- iii. Software will prepare detailed link program based on data fed by lobby staff for crew.
- iv. It shall be possible to change Loco Pilot booking details for next 24 Hrs.
- v. Getting daily report of planned booking and actual booking of crew shall be possible.
- vi. Monthly reports of individual Loco Pilots in terms of KMs & duty hours date wise shall be possible based on real time data from TMS.
- vii. It shall be possible to calculate running allowance of crew based on real time data from TMS.

#### 7.6 Interfacing of TMS with Crew Management System (CMS)

- i. TMS will be suitably interfaced with this module to take automatically the crew details from the detailed link table or the online data fed by lobby staff. TMS based on this information will show online position of Loco Pilots on train details query on controllers terminals. The online position of crew shall be available to lobby staff either on TMS terminal of lobby or separate Crew Management terminal having CMS loaded.
- ii. In case online position is not fed by lobby staff, TMS will take data from detailed link table with suitable tag that data is from link table. It shall be possible to change the name of Loco Pilot when prompted to do so by server.
- iii. It shall be possible to get query based details of crew like running details, etc.

#### 7.7 Time Table Planning System (Offline)

- i. Software for offline Time table planning shall be provided for the whole line.
- ii. Data base of infrastructure like signal distances, permitted speed of trains, Signal interlocking, Axle Counter Track section lengths etc. required for



generation of time table shall be provided on main/simulation server or on separate server. Based on this data, time table system software shall prepare a time table. It shall be possible to modify/edit the generated time table offline and after testing of same on simulator terminal, load it on the TMS system.

- iii. Time table shall be able to give section wise train graph.
- iv. Suitable interfacing shall be provided with TMS so that related data can be taken from timetable system to TMS or vice versa.
- v. It is envisaged that the Time table preparation tool shall be available on a simulation terminal to aid the operator to prepare timetable.
- vi. It shall also have simulation facility to find any Headway or crossover conflicts in the time table
- vii. The time table preparation module shall have following features:
  - a. The system shall have a standalone Windows based tool to do the timetable planning in the offline system.
  - b. It shall be possible to edit timetable.
  - c. It shall be possible to Create/Edit/Delete a train service.
  - d. A train service shall have following (but not limited to) attributes:
    - i. Train ID;
    - ii. Type of Train Load (Container, Petroleum products, Food grains etc.),
    - iii. Stopping pattern telling which station it stops at;
    - iv. Running section telling which path it takes;
    - v. Time at each stopping station;
    - vi. Length of train in number of wagons;
    - vii. Creating train ID; if required.
  - e. It shall be possible to use train service template while creating a new train.
  - f. It shall be possible to define trains for a specific day of the week.
  - g. The time table compilation and proving system shall calculate and generate number of train trips and train kilometers for all time table trains.
  - h. It shall be possible to transfer the timetable to TMS by authorised user only.

## 8. TRAIN GRAPH REQUIREMENTS FOR TIME TABLE SYSTEM

- i. The train graph shall draw time in X-axis and stations on Y-axis.

- ii. The train graph shall have facility to show different types of train loads in different colors.
- iii. It shall be possible to select the direction and day for which the graph needs to be plotted.
- iv. It shall be possible to take printout of train graph on a printer/plotter.
- v. It shall be possible to take train frequency reports from the timetable database.

## 9. LOG AND ALARM SYSTEM

### 9.1 Event Log

- i. All important events (command, indications, errors, system information etc.) shall be logged in a log SQL database for later printing and analysis.
- ii. Log database shall be separated into 3 sections; system log, short term log & long term log. The time span of log will depend on the size of database and intensity of log events.

### 9.2 Replay of Event Log

- i. The replay function shall show history of events that has happened earlier in the TMS system. The replay of train movement shall be on simulation terminal.
- ii. When replay is started, the dynamic status for infrastructure, train number, system pretest and alarm list as well as the pictures on the screen shall be initialized.

### 9.3 Traffic Related Alarms

- i. Vital traffic operator related alarms shall be:
  - a. Failure of any Signalling gear including Electronic Interlocking, I/O controller, PSS, Axle Counter, Signal Lamp, Point Machine, Line side Electronic Unit(LEU) of TPWS (Input to be provided by ST P-5A Contractor) etc. in the entire section under scope.
  - b. Routes not released after passage of train.
  - c. Alarms initiated by Health Monitoring Systems of Points, cables, PSS, Earth Leakage Detector, ACs provided by the Contractor etc.
  - d. Train Not Described Alarm (NDA).
  - e. Train waiting for more than 5 minutes at a manual stop signal not taken off.
  - f. Train stopping at OFF signal for more than 2 minutes.
  - g. Any other unscheduled train stoppage.
  - h. Any unscheduled train detention in excess of prescribed time.

- ii. Alarms a, b and c above shall be displayed on the Signal Fault Controller terminal in addition to terminals of SCOR and concerned ASM. Concerned ASM will imply for a particular station with block section on either side. For these alarms, facility of SMS generation through GSM(R) for maintenance staff shall be provided.
- iii. All the above alarms shall be arranged in priority levels in consultation with the Engineer.
- iv. It shall be possible to prepare failure reports in approved formats and also print the same.

#### 9.4 Network Related Alarms

- i. All alarms not directly related to traffic operations shall be considered to be Network related alarms.
- ii. These shall be displayed on the Network Management System terminal only.
- iii. These shall be arranged in priority levels in consultation with the Engineer.
- iv. Failure of Network Communication / inability to access any of the nodes, defective terminals and hardware & software failures shall initiate an alarm.

#### 10. SOFTWARE DETAILS

1. All software shall be based on open system concept and shall be independent of type of processor or hardware platform.
2. It shall be based on co-operative or client server processing architecture with distributed processing logic.
3. Following modifications shall be possible without modifying the source program:
  - i. Facility to add users with password authentication;
  - ii. Facility to delete an existing user;
  - iii. Change the priorities allocated to users;
  - iv. Change areas of jurisdiction;
  - v. Change various particulars of a train;
  - vi. Introduce new alarms with varying priorities;
  - vii. Changing the details of any node;
  - viii. Introduction of new nodes;
  - ix. Create, modify and delete sectional area on the train graph display;
  - x. Change the various colours allocated for various trains tag;
  - xi. Change x & y coordinate scales;

- xii. Menu and contents of formats on ASM terminal;
- xiii. Addition & alteration to the screen formats on VDUs at train originating stations;
- xiv. Incorporation of additional infrastructure such as yards, sidings, new lines, extension of loop lengths etc.

## 11. INTEGRATION WITH TRAIN RADIO COMMUNICATION SYSTEM

Suitable arrangement will be provided for entering of Train ID in Cab radio at the starting station of DFCCIL route and its confirmation from TMS by Radio Server.

\*\*\* End of Annexure 1\*\*\*

## Annexure 2: Train Monitoring & Diagnostic System – Technical Specification

**Details given below pertain to TMS to be provided by P5 Contractor in Rewari-Vadodadra section (Phase 1) of DFCCIL Western corridor. Similar details pertain to TMS to be provided by P17 Contractor in JNPT-Vadodadra section (Phase 2) of DFCCIL Western corridor.**

### 1. INTRODUCTION

This specification covers the technical requirements of the Train Monitoring and Diagnostic System (hereafter called TMS) for use on Rewari-Vadodara section of Western Dedicated Freight Corridor.

### 2. FUNCTIONAL REQUIREMENT SPECIFICATION (FRS)

2.1 Signalling work including TMS in western Corridor is divided into two phases as under:

Phase 1: Rewari-Vadodara: to be provided by P-5 Contractor

Phase 2: Dadri-Rewari and Vadodara-JNPT: to be provided by P-14 & P-17 Contractors respectively.

2.2 TMS shall be designed to work as an integrated system of both phases covering full line of Western corridor. Suitable interface shall be developed with P-14 & P-17 Contractors to achieve this functionality. Refer Annex. 7-5 for details.

2.3 The system broadly envisages the functionality as described in FUNCTIONAL REQUIREMENT SPECIFICATION kept as Annexure 1 in Particular Specification.

2.4 Wall display shall include display of SCADA also. Provision of SCADA for Phase 1 will be done by P-4 contractor and will provide feed for display controller. However, Work stations on tables of Traction Power Controllers showing SCADA display shall be provided by P-4 contractor.

### 3. GENERAL DESCRIPTION

- (i) TMS is broadly computer based information storage cum retrieval system located in the control office. System collects Signalling information (signals, points, Axle counters, route setting etc.) from various station interlockings and Auto Locations on real time basis. It also collects the train identification information from the train originating stations normally retrieved from Time Table or keyed in by concerned ASM/SCOR.
- (ii) All the information is processed automatically by the system and movements of trains at various locations together with the status of Signalling gears is displayed on the controller's/ASM's video screen on selective station /section basis.

- (iii) The TMS is to provide an effective system of regulating trains by monitoring their movements and facilitates in taking timely decision for diversion of trains, induction/withdrawal of locos etc.
- (iv) The system shall also provide for generation of punctuality reports, unusual reports, train graphs, loco and crew links and other MIS related reports. These reports are mentioned in FRS.
- (v) The technical requirements covered in the specification are minimum essential requirements.
- (vi) The hardware of the system shall be based on the latest design philosophy and shall be based on the state of art technology. It shall be fault tolerant and modular. The equipment/subsystem shall be capable of continuous use at rated capacity for long duration on a sustained basis.
- (vii) The bidder shall provide tender specific authorization from the manufacturer of mimic / Video display system in Original to quote for the tender.
- (viii) The system shall be capable of being upgraded to CTC at a future date.

#### **4. SYSTEM DESIGN SPECIFICATION**

##### **4.1 Proposed Sig. & Telecom Infrastructure of Western DFC**

###### **A. Signalling**

- i) Signalling work including TMS in Western Dedicated Freight Corridor is divided into two phases as under:
  - Phase 1; Rewari-Vadodara
  - Phase 2: Dadri-Rewari and Vadodara-JNPT
- ii) List of Junction and Crossing stations is given in Annexure 3.
- iii) Junction stations will have interconnection with nearby station of Indian Railways.
- iv) All the LC gates will be interlocked. List of LC gates is given in Data Book Vol. IV of Bid Documents.
- v) Block sections in Rewari-JNPT section will be provided with Automatic Signalling with signal spacing of about 2 Kms.
- vi) Four aspect LED signals will be provided.
- vii) Suitable PSS shall be provided to get reliable power supply for Signalling system.
- viii) Stations will be provided with Electronic Interlocking and VDU type indication cum control panel.

- ix) Train Protection and Warning System (TPWS) will be provided in Rewari-JNPT section to monitor observance of speed limits, stop signals etc.
- x) Dadri-Rewari section will be provided with Absolute Block Signalling out of which a total of 3 long Block Sections will be provided with Intermediate Block Signalling (IBS).

#### **B.Telecommunication**

- i) Optical fibre based communication system with drop and insert MUXes and STM equipment shall be provided at every station and GSM(R) base stations. For TMS, required dark fibre or bandwidth as required will be provided for connectivity using LAN.
- ii) GSM(R) based Mobile Train radio shall be provided.
- iii) Digital Electronic exchange system.
- iv) GPS clock.

#### **C.Train Operation**

- i) About 140 trains are expected to run in each direction every day.
- ii) Electric Loco Maintenance Depot (ELMD)will be located at Rewari.
- iii) OCC will be in or around Ahmedabad city within about 15 Kms from Right of Way.
- iv) Backup Control Centre (BCC) shall be provided by another Contractor.

#### **D.Details of Basic Application Data input to the system**

These are available in Annexure A attached to this specification.

### **4.2System Design Considerations**

The following will be the broad guidelines (not excluding the others) for the design:

i)The DFCCIL Western Corridor network as described in para 4.1 above is to be considered during overall design of the system. The Network, Central Server, wayside station computer processing speed, memory capacity, and mimic panel capacity shall be sufficient for the same. The capacity of power equipment at OCC and at wayside stations shall be designed accordingly.

ii)It shall have provision to interface in future with any additional TMS system for new corridor.

iii)Future requirement mentioned above is only for design considerations and necessitate modular design of the system as a whole so that expansion can be done at a later date by minimum disruption to the system and at a minimum cost. However, the system shall be able to give performance as per para 4.3.The Tenderer should be able to support conformance to para 4.3 parameters during design as well as testing by suitable data.

#### 4.3 Performance Requirements

The Central Server, communication server, entire network of control centre and FIUs shall have capacity to handle data for following infrastructure (approximate):

1. 60 Stations
2. 300 Simultaneous trains.
3. Indications considering Auto signal every 2 kms. and about 2 interlocked LC gates.
4. All lines except sidings fully provided with Axle Counter track sections between every two Auto signals as required. Clause 5.4.1.2(1) of the specification may be referred to for details.
5. Data inputs related to individual train time table.
6. TMS indications shall include: -

SR	OBJECT	NO. OF INDICATIONS	DETAILS OF INDICATIONS
1	Main signal	4	R, Y, YY & G
2	Shunt signal	2	ON& OFF
3	Point	2 + Lock	NORMAL & REVERSE
4	Axle Counter Track section	2 + Error	CLEAR, OCCUPIED& ERROR
5	Route	2	SET AND LOCKED& RELEASED
6	LC gate	2	CLOSED & OPEN
7	Auxiliary signals like A marker, Calling ON, G/AG marker	2	Calling-ON: ON & OFF Others: Lit & Unlit
8	Train ID	1	8 DIGITS
9	Failure of points, signal lamps etc.		Flashing Indications

In addition, suitable indication of having blocked any particular gear shall be provided.

#### 4.4 Expandability

The Central Server, communication server, entire network of control centre and FIUs shall have capability to be expandable to handle data by additional 20%.

#### 4.5 Dynamic Performance

The commissioned system shall have the following dynamic performance parameters:

1. 300 simultaneous running trains;
2. 50 route commands per minute (after provision of CTC in future);
3. 200 other commands per minute;
4. 1500 indications per minute.



#### 4.6 Automatic Route Setting (ARS)

It shall be possible to provide this facility in future along with CTC.

#### 4.7 Component Grade

- (i) All components including the critical components, ICs, Microprocessors etc. shall be of standard grade.
- (ii) Work stations shall be of Industrial grade.

#### 4.8 Scalability

The system shall be scalable to take into account expansion and the improvements in train operation and expansion of network.

#### 4.9 Reliability

1. The data base structure shall be such that it provides full handshaking for processing each event so that hardware failures are detected and Data integrity shall be maintained. To have high reliability, both software and hardware redundancy shall be inbuilt in the design. The tenderer shall provide details of the same. MTBF for each of the subsystems and complete system shall be declared by the tenderer and calculations in support of the same shall be submitted along with the offer.
2. Reliability Requirements: The reliability measure for the TMS shall be Mean Time Between Maintenance Action (MTBMA). The system shall achieve a MTBMA of no less than 7 days.

#### 4.10 Safety Integrity Level

TMS can have SIL0 or equivalent safety level.

#### 4.11 Maintainability Requirements

##### 1. Systems and Equipment Design

The system shall be designed to maximize availability during traffic hours, to minimize the amount of maintenance required to maintain the system and to ensure that any maintenance can be carried out with the minimum amount of time, skill and cost.

##### 2. Service Life

- i) All components, materials, software and other support required to repair and service TMS shall be available for at least 20 years from the Engineer's taking over of the works or section.
  - ii) All updated components shall be fully backward compatible with the originally installed components.
3. The Contractor shall notify the Employer in writing prior to deleting any component of the system from general availability and submit written assurances that it can provide functionally identical replacement units. The notification period for the deletion of the component and written assurances shall not be less than the lead-time for ordering or manufacturing the component plus six months.

#### 4.12 Flexibility

The system designed and implemented shall be flexible and modular enough to permit easy alterations/changes in terms of change in site data, addition or deletion of user, stations etc. and for easy reconfiguration to take into account future software/hardware developments.

#### 4.13 Standard Systems

The communication protocols and hardware standards shall be to CCITT / ITU standards and the tenderer shall demonstrate the same. The software used for TMS shall conform to UIC or any similar standards.

#### 4.14 EMI /EMC Immunity

All systems shall be immune to DFC's 2X25 KV AC Traction, 25 KV AC traction of nearby Indian Railways and other EMI /EMC interference that can generally be expected from a highly industrial environment.

#### 4.15 Fault Tolerance

The system shall be fault tolerant. This shall be built in as part of software and hardware at both OCC and at the wayside stations. Fault tolerance is a property of a system that continues operating properly in the event of failure of some of its parts. Fault tolerance can be achieved by anticipating exceptional conditions and building the system to cope with them and in general, aiming for self stabilization so that the system converges towards an error free stage.

#### 4.16 Energy Friendly

The system shall be so designed to ensure maximum power saving in all states of working. It shall be compliant to at least 4 energy stars.

#### 4.17 Bench Marking

The tenderer is required to give details of benchmarking the software in his offer.

#### 4.18 Man Machine Interface

The interfacing with the terminal operator by the computer system main (server) shall be user friendly and menu driven. In case of vital commands e.g. deletion of user, double checking facility shall be available for doubly ensuring the correctness of command that has been input by the operator. Various help levels shall be available for helping the operator. Tenderer shall give the various levels of help and prompt messages. It shall be possible to select the required option with minimum number of mouse clicks.

#### 4.19 Intensive Operation

The TMS system is intended to be used continuously 24 hours a day. Hence built in features / strategies to ensure that system is available on a continuous basis shall be provided. Particular care in system design shall be taken for

those components that have a tendency to fail on rugged usage or whose life is short.

#### 4.20 System Response Time

The system shall be so designed so as to achieve the overall objective of providing instant information for having meaningful action. The following vital response times shall be considered in design.

- (i) The response time between a change of state at a wayside station and its display at OCC shall not be greater than 2 Seconds.
- (ii) The time taken between initiation of a command for data /result /report and its display on VDU located on OCC LAN shall be as small as possible.
- (iii) Specified operating time does not include the operation time of field signalling gears.

#### 4.21 Database Query

It shall be possible to query the database either through format driven commands or by simple parameter related commands. These shall be drawn in consultation with the Engineer.

#### 4.22 System Clock

The system clock shall be synchronized with an extremely accurate external system clock (GPS), which shall drive the entire system. GPS clock shall be provided as a part of Telecom system. In case of failure of GPS clock, TMS clock shall keep on working based on last synchronized time.

#### 4.23 Minimum Requirements

The minimum hardware requirements are indicated in the tender documents. If the tenderer feels that additional hardware is required to achieve the defined objectives, he shall be obliged to supply the same without any additional cost.

#### 4.24 Maintainability

All the equipment shall have LED indications & supported by the specified vendors for diagnostics and assisting maintenance staff in fault finding. The software used shall be structured/modular self-diagnostics type and shall generate alarms in case of any failure.

#### 4.25 Reports

All the reports, their formats, input formats and colour schemes of train graphs etc. shall be finalised in consultation with the Engineer.

#### 4.26 Environmental Specification

All OCC equipment shall be able to withstand following environmental conditions without any degradation in the system performance:

a	Temperature Range :	Under operation: 5 degree Celsius to 45 degree Celsius Under storage: -10 degree Celsius to 70 degree Celsius
b	Humidity:	Up to 95% non-condensing
c	Shock:	15g, 20 msec, 1/2 Sine
d	Vibrations :	2.0 g Sine from 20 to 2000 Hz Min. 005 G2/Hz from 10 to 2000Hz

All Field equipment except VDUs shall be able to function without any degradation in their performance in the dusty, hot and humid environment as prevalent in the section.

The manufacturer shall indicate the optimum and worst environmental conditions that the equipment is designed for. Any limitation, extent and duration of extreme environment, which the equipment can withstand, shall be clearly indicated.

#### 4.27 Non Compliance

System/Protocols/ Software NOT complying with the above shall be brought out explicitly in the bid.

### 5. SYSTEM (TECHNICAL) REQUIREMENT SPECIFICATION

The main components of TMS are indicated in the block diagram appended at the end of this Annexure. Broadly, the system will comprise of but not limited to the following:

- i) Control office equipment like servers, terminals, LAN, etc.;
- ii) Overview mimic indication panel in control office;
- iii) Wayside field equipment (ASM terminals, field interfacing unit for interlocking, LC Gates, Auto Location Huts etc.);
- iv) Networking at OCC and in the field;
- v) MIS Reports/ alarms generating sub systems;
- vi) Drivers for display boards /VDUs at entrances;
- vii) Required Software;
- viii) Power supply arrangement at OCC & in the field;
- ix) Interfacing with GPS clock / Train Radio.

The final hardware configuration of the Application Server, printers and all terminals shall be got agreed by the Engineer.

### 6. CONTROL OFFICE EQUIPMENT

#### 6.1 Applications/Central Server

Applications server is the main system processor of the TMS for controlling and supervision. It shall have following minimum hardware configuration.

- i) Type : High end server
- ii) Processor – Minimum 64 Bit, Multi Core Multi processor (Intel Itanium 9300 or better)
- iii) Speed - Minimum 2 GHz.

- iv) N+1 Hot swap cooling
- v) PCI-X 8/16 port Smart Array (P600/P800) Serial Attached SCSI (SAS) controller
- vi) Core PCI-X dual port 10/100/1000Base TX LAN (with auto speed sensing; RJ 45 connector, Wake On LAN support)
- vii) HDD - Minimum 8X146 GB, Hot swappable, Ultra SCSI in RAID 1.
- viii) Blu-ray disc recorder.
- ix) Console - 21" colour monitor.
- x) Hot swappable redundant power supply.
- xi) I/O card - Adequate I/O facility.
- xii) Accessories - As required, if any.
- xiii) Supporting operating system – 64 bit
- xiv) Server shall be mountable on 19" rack.
- xv) Three Years warranty (from OEM)

Note: Central Server shall be provided in hot standby mode. The standby server shall be exact replica of Main Server. In the event of problem with main server, execution of application shall be seamlessly transferred to standby server without interrupting the operation and affecting the quality of service of operation. Similarly, if system is running on standby server and it fails, working shall be transferred to main server. Central Server shall be capable enough to deliver the required performance. Tenderer may supply more than one equipment/set of equipment to achieve the required performance along with its hot standby.

## 6.2 Functions and Facilities of Applications Server

The following shall be the main functions of the applications server.

- 1) It shall maintain and update in real time the position of all the TMS indications /information over entire Western Corridor / all field nodes to the last second.
- 2) It shall have all the software loaded and shall provide drive for the Overview mimic indication panel. It shall screen all the incoming information /data and shall revert back to the concerned agency for incomplete information and obtain it in the background.
- 3) It shall accept input data from the authorized operator / agency / node only. The access to the server shall be through a gateway with proper level of authority. It shall process the data as per requirements of the system.
- 4) It shall reply to the queries requested by various ASMs in the background without interrupting the section controllers.
- 5) It shall provide necessary data to print the various reports in suitable formats.
- 6) It shall enable display of both information and alarms on any of the terminals in OCC, IMDs, stations etc. as per pre - programming.
- 7) It shall be possible to store at least 30 days TMS data on the main hard disc. Tenderer to give details and archiving system proposed as considered essential.
- 8) It shall be connected via data channels on DFCCIL's optical fibre link with all the station signal interlockings through a suitable interface. The

aggregate information / status of Axle Counter Track sections, signals, points, route set, LC gate closed/open etc. of station and block section on either side shall be transmitted from wayside stations to applications server.

- 9) Networking with the wayside stations located outside OCC shall be on the DFCCIL's OFC / data channel with 100% redundancy. Vendor can suggest his networking methods between field stations and central server to achieve desired performance. All network elements shall be of managed type.
- 10) It shall be provided with adequate flexibility so that alterations and additions in the present functions and facilities are carried out with minimum disruption in the working system as and when required. It shall be compatible with future interlocking changes/yard alterations at wayside stations.
- 11) It shall be compatible for running off line forecasting module for computing expected arrival of trains.
- 12) Applications server equipment shall be fault tolerant system. It shall also be provided with Disc storage device to store real time database reflecting TMS information as well as an event logging database. Various terminal / equipment in the OCC office shall be interconnected with applications server using a dual local area network (LAN). Adequate redundancy of critical system, software and database shall be ensured.
- 13) It shall also be able to be setup as any OCC workstation.
- 14) Any other work to be done by applications server so as to obtain integrated system. Tenderer shall specify this.

### 6.3 Logging of Data on Servers

1. All the signalling / TMS data / indications shall be logged on the hard disc located on servers designated for this purpose. Data also includes fixed data e.g. Time Table, section layout and signalling scheme, crew booking, loco link details etc.
2. The following data need to be archived for subsequent use: -
  - a) All train related on line information. (Signalling indications, train movements details, trains description details etc.)
  - b) All system related data viz. node failures, hardware failures, communication failures etc.
  - c) All inputs made by the way side terminals (inclusive of ELMD, crew lobby) or by terminals at the OCC.
3. It is preferable to store data in a compressed and organized form so as to conserve the disc space. The tenderer shall provide details about the compression techniques used.
4. The storage shall be for a minimum period of 30 days.
5. It shall be possible to take INCREMENTAL back up on Blu-ray disc. Contractor shall provide additional hardware for this purpose.
6. It shall be ensured that the data is not lost while copying.
7. The notes recorded by the section controllers/ASMs shall also be logged.

These notes shall be linked to the concerned screen and context.

#### 6.4 Training Server and Terminals

These shall be provided as standalone with its own LAN at the OCC or any other location as decided by Employer for training and simulation purposes as per following (but not limited to) details:

1. It shall have the identical configuration of Central Server and facilities as of Central Server. It shall be equipped with the following:
  - (i) One terminal for Trainer with 3X21" VDUs;
  - (ii) Five terminals for Trainees with 1X21" VDU;
  - (iii) Blu-ray Disc player for accessing archived data.
2. It shall be possible to configure Server or Trainer's terminal to work as active section controller's terminal in case of any of the controller's terminal becoming defective / out of service.
3. It shall be possible to configure Server or Trainer's terminal to work as active maintainer's terminal whenever required.
4. It shall be possible to access the database for analysis and simulation studies. The data or results thus generated after simulation study or analysis shall not be stored on the main memory of the Application server permanently. To prevent the same, both hardware and software checks shall be provided. It shall be possible to store it in its own hard disc.
5. For simulation studies, it shall be possible to work on train graphs and time tables interactively but OFF LINE. It shall be possible to alter or generate a new timetable by changing controlling parameters. It shall be possible to obtain past train graphs and schedule train graphs and correlate any of the data on train graphs for deducing results / reasons / solutions.
6. The data generated during the course of simulation shall be temporary.
7. It shall be possible to view the reflected changes made in train graph on the timetable.
8. It shall be possible to simulate a sample dynamic model of the train along with track layout that occupies and releases Axle Counter Track sections.
9. It shall be possible to work trains as per permanent timetable or temporary timetable as desired by proper authority. Timetable Generation and other such applications shall be through this terminal.
10. It shall be possible to have access to main database through Gateway for printing MIS reports or printing data generated at this terminal for analysis or simulation studies.

11. Simulator shall be able to test all commands and indications defined in application data.
  - i) Replay a previously recorded traffic situation based on the stored log of events and work on it by changing relevant parameters.
  - ii) It shall also simulate train movements by using simplified model of the dynamic properties of the train and the status changes caused in the current traffic by train movements.
  - iii) Perform simulation studies of traffic considering dynamic parameters like speed limit on signals, other temporary and permanent restrictions, braking characteristics, driver's reaction time etc.

#### 6.5 Chief Controller / Deputy Chief Controller /Section Controller Terminals

##### A.Hardware

Chief Controller / Deputy Chief Controller / Section Controller terminals (work stations) shall have the following **minimum** configuration:-

- (1)Type: Workstation(HP z400 or better)
- (2) Processor: 64 Bit Intel® Xeon® Six-Core Processor 3.20 GHz or better.
- (3) RAM: Minimum 8 GB.
- (4) SOLID STATE FLASH DRIVE: Minimum 120 GB
- (5) Monitor: 3 nos of 21" colour monitor, high resolution 1920 X1200
- (6)I/O card: Adequate I/O facility, Integrated Drive Controllers, Dual network Interface cards, High End Graphics card etc.
- (7)Accessories: As required, if any.
- (8)Three Years warranty (from OEM)

##### B.Facilities

1. All user initiated functions shall be accessible using Mouse & Key Board.
2. It shall be possible to enter commands through menus, selection in the pictures, functional keys or via text input.
3. All terminals shall be able to see complete yards & block sections of full western corridor.
4. The precise operation of objects and the content menus must be as agreed with the Engineer.
5. All displays shall be active and shall indicate traffic /operator related alarms.
6. It shall be possible to scroll from left to right and vice versa from one station to another without flicker. There shall be full flexibility in regard to display of information on any of 3 video screens.
7. In case of big yards with a number of lines, the yard shall not look congested on the screen and, therefore, predefined scrolling from top to bottom, left to right or vice versa shall be possible. In addition, it shall be possible to divide the bigger yards into suitable no. of pictures.



8. If train identification has not been entered by the train dispatching station, the section controller shall have facility of entering it on getting NDA (Non Description Alarm).
9. It shall be possible to open many windows on each VDU.
10. A window must be active when the cursor is moved in its frame and the operator must be able to issue commands only to those objects in active window.
11. The display shall be dynamic even if the related window on the screen is not active.
12. The various input displays and reporting formats (to be decided in consultation with Engineer) shall be used for dialogue between the operator and the terminal.
13. It shall be possible to view any of the train graphs on controller's terminal be it historical, previous or current.
14. In case of unusual events and delays of trains, system will facilitate the controller to enter the reason and other details in the prescribed formats. This shall form part of database and shall be used for MIS reports later. Alarms shall come along with format for entering the reason.
15. The controller shall be able to enter any inputs regarding rescheduling of trains. This data shall be considered temporary and the operator shall be prompted to input the duration for which the data shall be held valid.
16. The temporary valid data shall be given the same status as that of permanent data and all the time tables and trains graphs shall be generated as per this data.
17. The details of occupancy of berthing lines and sidings shall be available.
18. It shall be possible to view various MIS reports.
19. It shall be possible to mute the audio or change the volume.
20. It shall be possible to alter the viewing angle of the VDU monitor in the vertical and horizontal planes.
21. Current time and date shall be displayed on the VDU screen conspicuously.
22. Multiple operators shall control the system without interfering with each other.
23. Communication arrangements available at stations shall also be displayed symbolically.

### **C. Structure of Controller's Video Display**

- (i) The controller's display format shall be finalized in consultation with the Engineer.
- (ii) Opening screen shall be structured as under: -
  1. At the top of window, there must be a top menu showing time, date and alarm indications with predetermined priorities for traffic related alarms. It shall also have menu entry points.
  2. An alarm menu window related to area of his jurisdiction with an alarm priority.

3. A dialogue window (it will reflect the commands given).
4. Middle area for application windows.
5. Pop up and pull down menus shall be user friendly.

#### **D.Operator's Authority**

1. Authority to log in shall be protected through a password. Only authorized persons shall be able to log in and access related database.
2. Where commands are for remote control, checking will be done for each and every command with proper level of authority
3. Access to the server's application software & system software shall be restricted through the gateway and proper authority check.

#### **6.6 Terminals with Other Controllers**

These terminals with other controllers shall form part of LAN. These shall include Crew controller, Engineering controller or controller at any other location decided by the Employer.

##### **A. Hardware**

Other controller terminals (work stations) shall have identical configuration as of Section controller's terminal except that these shall have only one VDU of 21" size.

##### **B.Facilities**

The following facilities shall be available on these terminals:

1. It shall be possible to gain access to all reports as can be accessed by the section controller.
2. It shall be possible to access the applications server for retrieving reports in suitable format. All the formats for the reports shall be decided in consultation with the Engineer. System will have a provision that a report retrieved by a particular controller pertains to him only.
3. He shall be able to send message to the other controllers through his terminal by video flash /audio buzzer etc.

#### **6.7 Terminal with Signal Fault Controller**

This terminal shall form part of LAN.

##### **A. Hardware**

Signal Fault Controller terminal (work station) shall have identical configuration as that of Section controller's terminal.

##### **B. Facilities**

The following facilities shall be available on this terminal:

1. It shall be possible to gain access to all reports as can be accessed by the section controller
2. It shall be possible to access the applications server for retrieving reports in suitable format. All the formats for the displays /reports shall be decided in consultation with the Engineer. System will have a provision that a report retrieved by him pertains to him only.
3. He shall be able to send message to the other controllers through his terminal by video flash /audio buzzer etc.
4. It shall be possible to see complete yards & block sections of full Western corridor.
5. All displays shall be active and shall indicate signalling /traffic /operator related alarms.
6. It shall be possible to select display of only track layouts or different information on any of 3 video screens.

#### 6.8 Maintainer's Terminal in OCC

There will be provision of a fault logging cum diagnostic terminal along with A3 colour Laser printer in the system. Displays and printouts of equipment faults or communication failure occurring anywhere in control centre equipment shall be readily available on this terminal. In case of faults, the maintainer terminal shall be able to provide all the assistance for rapid detection of faults.

##### A. Hardware

- I Maintainer's terminal (work station) shall have identical configuration as that of Section controller's terminal.
- II A printer shall be connected for on line logging with the maintenance terminal for logging all network related alarms.

##### B. Facilities at Maintainer's Terminal in OCC

1. The maintainer's terminal shall be used for supervisory functions of the network and for observing any required nodes and their configuration at any time.
2. It shall be used for indication of all alarms, both operators related and network related.
3. It shall be possible to bypass any node if so required.
4. It shall be possible to configure terminals from this terminal.
5. It shall be used to provide fault logging & diagnostics for network equipment at element level.
6. Displays and printouts of equipment faults, communication failure occurring anywhere in the OCC or field network shall be readily available on this terminal.
7. In case of faults, this terminal shall provide all the assistance for rapid detection of faults.

8. Alarms shall be available on this terminal as follows:-

- Power supply failure at control centre, wayside stations, Auto Location Huts or any node;
- Air conditioning failure at Porta Cabins in Block Sections.
- Central control internal communication failure;
- Communication equipment failure;
- Field control unit failure;
- Failure of nodes;
- ASM terminal failure;
- System failure;
- Interlocking interface failure (Field Interface Unit);
- Any other indication considered essential.

All the above shall be treated as critical alarms.

9. Alarms shall be logged on 'ON LINE 'basis. These shall be recorded in file format so as to access particular file as required at a later date. Exception report (failure report of desired elements) shall be generated. File format to be decided in consultation with the Engineer.

10. This terminal shall have access to MIS reports.

11. Terminal will provide a pop up window to display a table to allow maintainer to correlate data communication with its associated field objects. Also, on line display about the following shall be available.

- Station being polled.
- Station transmitting.
- Station faulty.

12. Element level Network management (NMS) module shall be available on this terminal and shall show:

- i) The position of various nodes;
- ii) Identification of faults and their nature;
- iii) Current status and health of equipment and communication channels;
- iv) Memory utilization;
- v) Remote bypassing and changeover of faulty equipment;
- vi) Ability to check quality of communication from any node to the other on the network including bridges and routers. This shall be done in the background without visibly downgrading the system.
- vii) Facility to view system / network performance statistics on this terminal.

13. FAULT DIAGNOSTICS :

- i) Any malfunction in vital hardware subsystem/modules in the OCC will result in audio & visual alarm at the maintenance terminal.
- ii) The maintenance terminal shall have diagnostic software through which it will periodically scan all elements.

- iii) Diagnostic routine to check hardware like TMS field equipment (excluding interlocking installation) and data communication circuits shall be available.
  - iv) Shall have monitor programs to test connectivity.
  - v) It shall be possible to switch the transmission lines at all stations.
  - vi) It shall be possible to display polling status of stations.
  - vii) It shall be possible to capture all transmission events for analysis and fault finding of data transmission.
14. It shall be able to change the password configuration of the controllers /ASMs terminals.
15. It shall allow a fixed data information e.g. Layout, timetable etc. to be keyed in.

### **C. Network Management System**

1. NMS facility shall be provided on maintenance terminal by which work station computers, terminal servers, voice and data switching nodes and ASM terminals can be monitored at element level for performance and switching to back up paths can be carried out.
2. It shall be possible to monitor all elements of network of OCC and field units through NMS.
3. SNMP or standard protocol shall be used.
4. It shall contain real time LAN diagnostics.
5. Facility for Network performance statistics, communication testing and managing internal or external node on the network shall be made available

#### **6.9 Maintainer's Terminal in Signal Equipment Room (All Stations)**

There will be provision of a diagnostic terminal in every signal equipment room. It shall be connected on LAN for display of track layout which shall have scrolling facility. In case of faults, the maintainer terminal shall be able to provide all the assistance for rapid detection of faults.

#### **A. Hardware**

Maintainer's terminal (work station) in Signal Equipment Room shall have identical configuration as that of Section controller's terminal except that it will have only 1 no. of 21" colour monitor.

#### **B. Facilities at Maintainer's Terminal in Signal Equipment Rooms**

1. The maintainer's terminal shall be used for supervisory functions of the signalling equipment at concerned station and about half block section on either side. However, display for full Block sections shall be available.
2. It shall be used for indication of all alarms for the monitored equipment.

3. It shall be used to provide fault logging & diagnostics for signalling equipment at element level.
4. In case of faults, this terminal shall provide all the assistance for rapid detection of faults.
5. Alarms shall be logged on 'ON LINE 'basis. These shall be recorded in file format so as to access particular file as required at a later date. Exception report (failure report of desired elements) shall be generated. File format to be decided in consultation with the Engineer.
6. Each card status of an equipment rack (e.g. EI, I/O cards) shall be indicated in green for normal and in red for failure. Further details shall be displayed when any card of the equipment on this screen is clicked.
7. It shall be possible to select relays and display its status.
8. All PSS and any other power supply systems shall be monitored.
9. If monitoring of MSDAC can be done on the same terminal, then it shall be incorporated.
10. All signalling drawings of concerned station and adjoining block section shall be loaded on the terminal in pdf format.
11. All manuals pertaining to installed signalling system/sub-system at station and adjoining block sections shall be loaded on the terminal in pdf format.

#### 6.10 Signalling SE/JE's Terminal

One terminal each similar to the ones provided in signal equipment room shall be provided in the office of every sectional Signal SE/JE. It shall have similar facilities of display, diagnostics and loaded documents for the section under jurisdiction of concerned SE/JE.

#### 6.11 Miscellaneous User Terminal

Miscellaneous terminals shall be located at important / relevant office to have first hand information about running of trains in visual form and in required format. This terminal shall be either connected directly on LAN or in field network.

##### HARDWARE

Miscellaneous terminals (work stations) shall have identical configuration as that of Section controller's terminals except that it shall have only one VDU.

FACILITIES: It shall be able to see all the prescribed screens by menu driven commands with mouse.

#### 6.12 General Details

- i) All servers and workstations to be provided at OCC shall be of same type and make as approved by the Engineer.
- ii) All workstations to be provided at Field Network shall be of same type and make as approved by the Engineer.
- iii) All industrial grade PCs to be provided at Field Network shall be of same type of approved make.
- iv) All servers, workstations & PC (Terminals) at OCC & Field Network shall be provided with printer slot and minimum 2 spare I/O slots for future use.
- v) Vendor of servers, workstations & PC (Terminals) shall have service centres in India.

## **7. DUAL LAN SYSTEM**

### **7.1 Dual Terminal Server, Dual Communication Server & Other Interface Components**

#### FEATURES

The communication processor to be installed in the OCC shall have the following features: -

- i) It shall be dual and fault tolerant.
- ii) It shall generate E-1 data streams to be interfaced with one or more DFC's other corridor's data channel cards in the optic fibre cubicle at any of the stations or OCC based on standard non-proprietary protocol with error correcting mechanism.
- iii) It shall provide protocol conversion from the LAN to the line protocol.
- iv) It shall have adequate storage for buffering to inputs from LAN and for sending data.
- v) It shall be based on approved protocol for data circuits.
- vi) It shall have a suitable interface for connecting with DFC's other corridor's LAN on Ethernet port with an active Firewall for protection of TMS from Viruses entering from other corridor's side. This port is used only for extracting information from TMS to DFC's other corridors. In addition to this, minimum of two additional Ethernet ports shall be made available for connecting the TMS LAN with other LAN for interoperability among LAN.
- vii) Communication processor shall provide full support for the entire protocol stack of the external transmission network.
- viii) The communication protocol shall be TCP/IP.
- ix) Failure of any single FIU shall not cause failure of complete communication of TMS other than that of particular FIU.

### **7.2 Transferring Circuits to Backup OFC**

It shall be possible to interface and transfer the circuits on to the backup communication on redundant path of OFC, wherever available. The communication processor shall be capable of providing patch up facility.

### 7.3 Bridges, Gateways, Switches, Repeaters and Routers

1. These components shall be DUAL of approved make using standard protocols. All required networking equipment to be supplied under this item.
2. 30 % spare slots on switches, hubs etc. shall be kept spare for future use.

### 7.4 Networking / Connectivity in OCC (LAN)

- i) The local area network employed shall be Dual LAN Network based on FDDI/Ethernet/Serial communication.
- ii) Dual redundant link shall provide highly resilient communications network. System shall be tolerant to multiple simultaneous link failures, maintaining operation without degradation of performance. It shall be possible to perform maintenance on communication links without stopping the signalling system.
- iii) Data transfer to peripherals like printers & plotters can be at lower speed for each device using appropriate media with duplicate path.
- iv) For connecting peripherals, screened twisted pair cables shall be used.
- v) The hubs/switches/network components shall be dual. The connecting cables shall also be dual.
- vi) The cables used shall be of rugged type with capability to work data up to at least 100 Mbps.
- vii) There shall be facility to add more nodes in OCC and the wiring for additional 4 nodes shall be kept as spare.
- viii) The network operating system to be used for this purpose shall be got approved from the Engineer.
- ix) The connectivity of the cable with the connector shall be solid without use of any other interface or heat shrink joint.
- x) The conductors that make up the pair shall remain as a pair end to end.

### 7.5 Details of Field Station Network (WAN)

- i) All equipment shall be installed in standard 19" racks.
- ii) The time slots working shall have redundancy. However, it shall be possible to transfer all data from one time slot to a redundant time slot, if required.
- iii) The transmission with field stations shall be controlled by the OCC equipment by polling wherever transmission is in serial mode and not in star configuration.



- iv) Full duplex working shall be used.
- v) Safety data shall not be in bits but will be in ASCII characters.
- vi) In-built safety provisions shall be available to detect data corruption/ non-receipt of packets / node defect problems.
- vii) It shall be possible to bypass any station without interrupting the routine working.

#### 7.6 Wiring

- i) The wiring shall be protected in PVC casing and capping. Cabling shall be structured one.
- ii) All wiring shall be colour coded and shall have tags at the termination points showing the circuit number etc. for easy fault identification.
- iii) All wiring at the OCC shall either be concealed or done by internationally accepted wiring procedures and constructs.

### 8. VIDEO WALL DISPLAY SYSTEM

- i) An overview mimic indication panel in the form of a large wall display shall be provided in OCC with track diagrams of all stations/yards and also the automatic signalling sections in between the stations to show the complete track layout position / status of points, aspect of signals, level crossing gates, route set indication etc. in real time to provide controllers with an overview of the complete system.
- ii) Wall display shall include display of SCADA also. Provision of SCADA for Phase 1 will be done by P-4 contractor and will provide feed for display controller.

#### 8.1 General Description

- i) Display shall be of rear projection type based on single chip DLP Technology. It will consist of Display modules and Display Controller which will integrate various Display modules into a single logical Display Wall.
- ii) The wall display shall be made up of individual Rear View projection Display modules which shall be integrated to form a single video wall using Display Control Manager workstation and Video Wall Management Software.
- iii) It shall be rugged and of industrial standard and shall be able to work on 24X7 basis.
- iv) The display windows shall be freely resizable, rescalable and repositionable on any part of the display wall.
- v) Black background shall be used for getting proper contrast. Other colours used shall be such as to give bright and easily distinguishable display.

- vi) The Mimic Indication Panel shall display all Axle Counter Track sectioned lines and all interlocked signal aspects of track layouts of stations & block sections.
- vii) Station codes, signals, tracks, train description etc. shall be displayed. The field objects shall be as per geographical layout. For trains, however, the train IDs only may be displayed.
- viii) Sufficient space shall be made available between the track indications for alphanumeric displays.
- ix) The Overview Mimic Indication Panel, in addition to display of important indications, will also provide alarm indications of failure of points, signals, Axle Counter Track sections etc., as the case may be. Less significant objects/indications like non Axle Counter Track sectioned sidings etc. will be shown with a thick line of suitable colour on the overview panel.
- x) The Overview Mimic Indication Panel unit shall display the occupancy of various track sections along with the train description. Train ID box shall indicate different colours for different type of loads e.g. Container, Petroleum products, Food grains etc. In case train number is not keyed-in, the same shall be shown as flashing unknown train identifier mark along with Non Described Alarm (NDA). Alarm will stop as soon as the train number is keyed in by the controller / wayside ASM.
- xi) If a train has stopped at any location enroute for more than the prescribed minutes, an alarm shall be raised to draw attention of the controller.
- xii) It shall be possible to update changes in yard layout through software from the maintenance terminals without any requirement of change in the hardware. The uploading time of software changes shall be minimum and it shall be possible without complete shutdown of the indication system.
- xiii) It shall be possible to show the temporary speed restrictions by showing the Tag box or by any other means.
- xiv) Suitable Interface equipment and drivers for linking indication panel with applications server shall be provided.
- xv) The terminal server /driver for driving the overview mimic indication panel shall have full-fledged capacity to drive described displays from provided equipment + 20% spare.
- xvi) The overview mimic indication panel shall be vertical and placed in an arc shape mode so that all the parts of the panel are seen clearly with ease without strain when seen by Section Controllers and Chief Controller from their farthest seats.
- xvii) Legibility, lighting, contrast, content, font size, viewing distance etc. shall be kept in view while designing graphics for the display.
- xviii) Surface shall have matt finish to keep it glare free.
- xix) Glass backing shall be used so that there is no screen build bulge in.

- xx) Station layouts can be arranged in a number of rows– top, middle and bottom.
- xxi) The lowest row shall not be below 1.5 meters (approx.) from the floor to ensure proper viewing angle. This shall be got agreed by the Engineer.
- xxii) Pedestal shall be made of Aluminium extruded and anodized members.
- xxiii) Front of the pedestal shall be covered.
- xxiv) Sufficient space shall be made available between the track indications for alphanumeric displays.
- xxv) It shall be compatible with the international VIDEO Standards.
- xxvi) It shall have high MTBF and low MTTR. Values of the same shall be given with supporting calculations/data.
- xxvii) Rear Projection System shall have rear service access.
- xxviii) Projection system will have cooling fan with dust filter.
- xxix) Variable ballast settings with step change function shall be provided.
- xxx) It shall be possible to increase/decrease the colour intensity, contrast adjusting etc. screen wise through the system console. It shall be possible to memorize the parameters of one screen and use the same parameters for all the other screens.
- xxxi) The unit shall be compact and energy efficient so as to conserve on space and power consumption.
- xxxii) The tenderer shall give entire projector support software packages, documentation and details of maintenance.
- xxxiii) All kits required for achieving the above shall form an integral part of the system.
- xxxiv) Any other facility to make the system more user friendly shall be incorporated by the tenderer.
- xxxv) Indigenous service support shall be available for the chosen make.

## 8.2 Minimum technical Requirements of Display Wall

Item	Specification
Projection Technology	Display Unit/Rear Projection Module must be based on Single Chip DLP-based Rear Projection Technology.
Architecture	The display unit/rear projection modules shall have in-built illumination system.
Display size	The diagonal size of each visual display unit/rear projection module shall be Minimum 70inch Diagonal (to be got agreed by the Engineer).
Resolution	Each individual cube minimum Full HD (1920x1080 pixels)

Aspect Ratio	16:10 or 16:9
Lamp type	LED - RGB (1 each of about 12 sqmm surface area). Multiple LEDs of each colour to achieve this surface area not acceptable.
Display redundancy	In case of failure of any 1 or 2 LED lamps, it shall be possible to display the Image with balance 2 or 1 LED lamps to continue the display and automatically switch the original display colour into other available colours. Error shall also be shown by Diagnostic LED indicators in case of LED lamp failure.
Cooling Mechanism	Cooling shall be by means of heat pipe. No pump based mechanism is acceptable due to possibility of failure.
Brightness	Shall be minimum 700 lumens.
Brightness Uniformity	95%. To automatically provide brightness and color stability over time and across the entire display.
Contrast ratio (Full field)	1400:1
Color gamut	Better than 100%EBU
Screen	Burn free. No memory and no ghosting. No constant flicker. Low reflection with matt finish.
Screen type	Fresnel/ Lenticular/ Black Bead /Cross Prism(XPS)
Screen to screen gap	Shall be adjustable up to 1.0 mm or less for seamless viewing.
Viewing Angle	Full viewing angle shall be 180 degrees.
Half Gain Angle	Horizontal : ± 35 degrees Vertical: ±33 degrees
Pedestals	Shall be customized as per project requirements.
Input terminals	5x RGBHV on BNC HD-15 2x DVI-D Component video BNCx3(Y/Pb/Pr, Share with Analog RGB BNC ) RS232C RS422 RJ45
Output terminals	1xRS422 RJ45 1xDigital DVI-D
Inputs (Additional)	System shall have the following additional inputs ports: 5x RGBHV on BNC HD-15 2x DVI-D CVBS Video BNC Component video BNCx3(Y/Pb/Pr, Share with Analog RGB BNC )
Component input Compatibility	480i, 480P, 720P, 1080i, 1080P
Video Compatibility (CVBS)	NTSC3.58/NTSC4.43, PAL, SECAM
Auto detection	System shall automatically search the source which has input signal after signal plug- in.
Source Redundancy	System shall be able to switch to secondary DVI input if primary DVI input is not available. System shall also automatically switch back to primary DVI from secondary DVI input as soon as primary DVI input becomes available again.
Video feature	10 bit motion adaptive de interlacing for HD and SD

	Detail enhancement (H, V peaking). Adaptive detail enhancement featuring sharpness and texture enhancement (STE). Enhanced noise reduction with Mosquito noise reduction( MNR)and Block Artifact Reduction( BAR).
High Resolution Inputs	Shall accept QXGA inputs directly into the cube.
Power control:	1 AC power ON/OFF switch
wire control:	RS232C/ RS422 input
LED indicator	Power LED(Standby: Red , On :Green), Fan LED, Lamp LED.
On Screen Display	Input selection, Picture, Image, tilling shall be adjusted by On Screen Display. Warping - Barrel, Pincushion and keystone. Edge Blending. In case of any failure in projection module, system shall be able to generate 2 levels of Alarms on wall: Yellow level: Warning Red level: Critical
OSD Languages	English
IP /Remote Control	User should be able to control and monitor each Projection module through Internet / Intranet.
AC Power Input Range	90~240VAC, 50 +/- 3Hz.
Component Life-LEDs	>60,000 Hours
LED Control	Dynamic control
Start up	Instant hot restart
Operating Temperature	5°C to 35°C.
Storage Temperature	-20°C to +60°C
Operating Relative Humidity	Maximum 95%non condensing.
Component life - DMD Panel	Shall be greater than 650,000 Hrs

### 8.3 Display Wall Controller

- i) It shall be of Industrial Grade.
- ii) It shall provide control over data and graphics suitable for 24 X 7 operation capable of driving demanding high resolution tiled wall display.
- iii) It shall include fully integrated user friendly display wall management software.
- iv) It shall have fault resilient modular architecture for easy expandability.
- v) Wall Manager Software: It shall be possible to create, edit and save display layout to be projected on screen through wall controller and be launched on screen as per requirement. Simultaneous multi display system along with layout editor is required.

#### 8.4 Minimum technical Requirements of Display Wall Controller

Group	Specification Item
<b>Features</b>	<ul style="list-style-type: none"> <li>• Robust processing platform</li> <li>• Redundant, hot-swappable hard drives, cooling fans and power supplies</li> <li>• Built for high performance</li> <li>• High-performance input and output hardware processing technologies</li> <li>• PCI Express switch fabric</li> <li>• To support Minimum of 64 display outputs, 128 video inputs and 48 RGB/DVI/Component inputs</li> <li>• Exclusive easy-to-use wall-management software</li> </ul>
<b>Processor</b>	4/8 Core Intel® Xeon 64-bit 2.0 GHz CPU or better
<b>RAM Capacity</b>	* 18x 240-pin DIMM sockets Min 4GB and Shall be upgradable up to 192 GB 1333 / 1066 / 800MHz DDR3 ECC Registered memory
<b>Expansion Slots</b>	7 slots PCI-E 3.0
<b>HDD</b>	Minimum 1 TB Hard Disk. Support for up to minimum 6 Hard disks shall be available. Hard disk Capacity shall be upgradable.
<b>RAID</b>	* RAID 0, 1, 5, 10 support (Windows).
<b>Networking</b>	* Dual-port Gigabit Ethernet Controller inbuilt. * Support for Add on Network adapters. * Support for Optical Fibre interface Adapters.
<b>OS</b>	* Shall support 64-bit Operating System
<b>Power Supply</b>	* 800W (1 + 1) Redundant AC-DC high-efficiency power supply w/ PFC * AC Voltage 100 - 240V, 50 +/- 3Hz
<b>Chassis</b>	* 19" industrial Rack mount movable Front Panel shall have lockable Door to Protect Drives.
<b>System Reliability</b>	* Operating Temperature: 10° to 35°C * Storage Temperature: -40° to 70°C * Humidity: Up to 90% non-condensing
<b>System Cooling</b>	* 3x 5000 RPM Hot-swap PWM Cooling Fans * 2x 5000 RPM Hot-swap Rear Exhaust PWM fans
<b>Composite video inputs</b> <b>type/formats</b> • NTSC M, NTSC J, NTSC N, NTSC 4.43 50/60, PAL I, PAL B, PAL D, PAL G, PAL H, PAL M, PAL N, PAL NC, PAL 4.43 60, SECAM B, SECAM D, SECAM G, SECAM K, SECAM L, SECAM LD <b>frame (refresh) rate</b> • 30 fps (NTSC) • 25 fps (PAL) <b>video inputs/system</b> • 128 (simultaneous) <b>advanced processing</b> • 3D comb filtering with advanced processing <b>RGB/DVI input expansion</b>	

<p><b>number of input sources per system</b>• 48  <b>analog input connection type</b>• DVI-I (comes with VGA adapter)  <b>digital (DVI) input connection type</b>• DVI-I  <b>analog resolution/source</b>• 2048 x 1536  <b>digital resolution/source</b>• 2560 x 1600 (with optional DL-DVI input board)  <b>support for non-interlaced sources</b>• Yes  <b>form factor</b>• 64 bit</p>	
<p><b>Display outputs</b>  <b>number of display channels</b>• 64  <b>resolution/channel (analog)</b>• 2048 x 1536 @ 60Hz  <b>resolution/channel (digital)</b> • minimum 1920 x 1080 @ 60Hz  <b>graphics memory</b>• minimum 512MB per card</p>	
<p><b>Redundancy Support</b></p>	<p><b>System Shall have the redundancy support for following:</b></p>
	<p>Controller</p>
	<p>Controller Hard Disk Data</p>
	<p>Power Supply</p>
	<p>LAN</p>
	<p>Cooling FAN</p>
<p>Scenarios</p>	
<p><b>Warranty</b></p>	<p>Three Years warranty (from OEM)</p>

#### 8.5 Technical Requirements of Wall Management Software

<p><b>Client &amp; Server based Architecture</b></p>	<p>Shall support Multi client/Console control for the Wall layouts.</p>
<p><b>Scaling and display</b></p>	<p>Software shall enable user to display multiple sources up to any size and anywhere on the display wall.</p>
<p><b>Controls</b></p>	<p>Software shall support control of Brightness, Contrast, Saturation, Hue, filtering, Crop and Rotate function as per user requirement.</p>
<p><b>RS232, TCP/IP</b></p>	<p>RS232 &amp; TCP/IP support shall be available for other interfaces.</p>
<p><b>Remote Control</b></p>	<p>Control of wall from Remote PC through LAN shall be possible.</p>
<p><b>Auto Source Detection</b></p>	<p>Software shall support auto source detection.</p>
<p><b>Layout Management</b></p>	<p>Shall support for Video, RGB, DVI, Internet Explorer, Desktop Application and Remote Desktop Monitoring Layouts.</p>
<p><b>Scenarios</b></p>	<p>Software shall be able to save and load desktop layouts from Local or remote machines.</p>
<p><b>Layout Scheduler</b></p>	<p>Shall be possible to schedule all the layouts as per user convenience.</p>
	<p>Software shall support auto launch of layouts according to specified time event by user.</p>
<p><b>Launch Application</b></p>	<p>Software shall be able to support.</p>
<p><b>User friendly</b></p>	<p>Software shall be user friendly.</p>
<p><b>Protocol</b></p>	<p>VNC(Virtual Network Connection)</p>
<p><b>Interface</b></p>	<p>LAN</p>

<b>Scaling and display</b>	Display of multiple sources up to any size anywhere on the wall shall be possible.
<b>Console View</b>	<b>Software shall enable user to select following views:</b>
	Primary Display
	Secondary Display
	Full Desktop
	Selected region
	Selected application
<b>KVM Support</b>	Keyboard, Mouse Control.
	Enable/Disable Keyboards and Mouse Controls.
<b>Short cut Keys</b>	Shall support.
<b>Control operator workstations</b>	Software shall be able to Support.
<b>Multiple concurrent client users</b>	Software shall be able to Support.

## 9. POWER SUPPLY ARRANGEMENT

### 9.1 Load of TMS

Load of TMS shall be combined with other Signal & Telecom equipment loads in OCC as well as at stations and combined PSS provided as per details given in bid documents. Capacity of PSS in OCC shall be determined by taking load requirement of Phase 2 TMS also and calculations got agreed by the Engineer.

### 9.2 Earthing of Equipment

- i) The Contractor shall make suitable arrangements to earth all equipment at all locations including OCC, stations, lobbies etc. for EMC/EMI protection.
- ii) Earthing design shall be got approved by Engineer.
- iii) Earthing shall be maintenance free.
- iv) Earthing value shall not exceed 1 Ohm.

## 10. WAYSIDE STATION EQUIPMENT

### 10.1 General

- i) At wayside stations, following equipment / units shall be installed.
  - a) **LINE INTERFACING UNIT (LIU):** This is the front-end unit that will interface with the field units (FIUs), ASM terminals, VDUs etc. at one end with data cable at the other end for transmitting / receiving information in the required format. Data cable is connected at the far end to optical interface card located in optic fibre cubicle.
  - b) **FIELD INTERFACING UNIT (FIU):** This unit will interface with the potential free contacts in Signal Equipment room and extend data to / from Electronic interlocking.
  - c) **ASM TERMINALS:** These are for inputting data /querying functions and are Work Station terminals.
- ii) The hardware installed at stations shall be modular and rugged.
- iii) The modules to be provided at various ASM Locations shall be identical.



- iv) The protocol and design of the modules supplied for accessing the TMS information shall be based on internationally approved standards and the tenderer shall give the details of the same in his offer.
- v) LED Indications and test points shall be available on various cards /Modules for easy fault diagnostics by the Maintenance personnel.
- vi) Field station hardware shall be housed in a 19” dust free, pre-wired rack. It shall be on Modular Computing Platform using 30 micron gold plating on slot connectors, Keyboards protected with protective membrane to avoid dust ingress, Front panel I/O access & direct PLC type wiring.

#### 10.3 Field Interfacing Unit (FIU) or PLC for Data Acquisition

- i) Field Interfacing Unit shall consist of - Modem for communication, Processor card, Power supply card, Interface to connect ASM PC, Required numbers of I/O cards, Required number of 19” rack/cabinet etc.
- ii) The field interfacing units shall acquire aggregated data from Signal Equipment room and transmit the same to communication network using standard protocol.
- iii) These units shall be installed in Signal Equipment room in a stand-alone mode. 20 % of the slots used for fixing I/O and peripheral cards shall be kept spare for future expansion.

#### 10.3 Auto Route Setting

This facility shall be provided in future along with CTC.

#### 10.4 ASM's Graphic Terminals

##### **A. Hardware**

ASM's Graphic terminals (work station) shall have identical configuration as that of Section controller's terminal.

##### **B. Facilities**

1. All user initiated functions shall be accessible using Mouse & Key Board.
2. It shall be possible to enter commands through menus, selection in the pictures, functional keys or via text input.
3. All terminals shall be able to display complete yard controlled by concerned ASM& full block sections on either side of controlled station.
4. There shall be on line display of train movements (including description) along with layout and status of signalling.
5. The precise operation of objects and the content menus must be as agreed with the Engineer.
6. All displays shall be active and shall indicate traffic /operator related alarms.

7. It shall be possible to scroll from left to right and vice versa without flicker. There shall be full flexibility in regard to display of information on any of 3 video screens.
8. In case of big yards with a number of lines, the yard shall not look congested on the screen and, therefore, predefined scrolling from top to bottom, left to right or vice versa shall be possible. In addition, it shall be possible to divide the bigger yards into suitable no. of pictures.
9. It shall be possible to enter train numbers for the train to be dispatched and entered train number shall be sent to central server.
10. There shall be two sub-menu items for the dispatch option of the main menu
  - (i) Scheduled Dispatch – To dispatch a scheduled train.
  - (ii) Special Dispatch – To dispatch a special train.
11. For scheduled dispatch, the window shall list pre-stored train numbers along with scheduled time of departure and destination station from timetable stored in Central Server. The ASM shall modify the departure time, destination if required. This shall be menu driven. The scheme for the menu driven commands shall be drawn in consultation with the Engineer.
12. The window for dispatching special train shall have the following:
  - Train Number
  - Time of Departure
  - Load Type (container/food grain/POL/Light engine etc.)
  - Destination
13. It shall be possible to input TRAIN ID (upto8 digits) along with other details such as special information about load, crew etc. These details normally shall be flashed by system automatically on departing station's ASM's screen as per schedule. If train identification has not been entered by the train dispatching station, NDA (Non Description Alarm) shall be initiated as soon as departure signal for the said train is taken off.
14. It shall be possible to query the Central Server in either formal menu driven commands or with simple parameter related command.
15. It shall be possible to get information of train position from central server. On selection of this menu, user shall be asked to select/enter the train number. The system would then display train position, crew name, Load type etc.
16. It shall be possible to open many windows on each VDU.
17. A window must be active when the cursor is moved in its frame and the ASM must be able to issue commands only to those objects in active window.
18. The display shall be dynamic even if the related window on the screen is not active.
19. The various input displays and reporting formats (to be decided in consultation with the Engineer) shall be used for dialogue between the operator and the terminal.

20. In case of unusual events and delays of trains, system will facilitate the ASM to enter the reason and other details in the prescribed formats. This shall form part of database and shall be used for MIS reports later. Alarm shall come along with format for entering the reason.
21. The temporary valid data shall be given the same status as that of permanent data and all the time tables and train graphs shall be generated as per this data.
22. The details of occupancy of berthing lines and sidings shall be available.
23. It shall be possible to view various MIS reports.
24. It shall be possible to mute the audio or change the volume.
25. It shall be possible to alter the viewing angle of the VDU monitor in the vertical and horizontal planes.
26. Current time and date shall be displayed on the VDU screen conspicuously.
27. Communication arrangements available at the station shall also be displayed symbolically.
28. Details of loads available on sidings at concerned station shall be displayed when cursor is placed on the siding.
29. Whenever a train / load leaves /enters the control area of concerned station or is put out of the system by placing it in the siding or sending it to ELMD, the ASM shall have facility to delete / enter such trains from / into the system.
30. Flashing message / instructions from the controller and information about expected arrival of next two trains on each line, cancellation and diversion of trains shall be displayed.
31. It shall be possible to send messages to central server. On selection of this menu, user shall be asked to select a pre-stored message, which shall then be sent to central server.
32. It shall also be possible to send any message, which is not pre-stored in ASM terminal. On selection of this menu, user shall be prompted to enter his message in a dialogue window, which then shall be forwarded to central server.
33. It shall be possible to test connectivity to Field Interface Units.
34. The system shall be able to rename a train standing on the current system.
35. It shall be possible to send message from TMS controller to ASM PC.
36. The system shall keep log of all the messages received from TMS.

#### 10.5 Terminals with ELMD & Lobbies

Terminals on the field network shall be provided at the designated locations that control the locos, crew booking and management.

These terminals shall have access to Loco controller whose terminal will have data for loco link modules, Loco maintenance schedule link, crew links and other related modules.

i) **HARDWARE – Latest Industrial grade embedded fan less PC**

- a) Chasis: Industrial grade rack mountable 19", 4U
- b) Slots: 14 slots supporting minimum 12 ISA/PCI slots and 2 CPU slots
- c) NOT USED.
- d) Processor: Minimum Pentium IV, Minimum 1.8 Ghz.
- e) Cache: Minimum 512 KB
- f) RAM: Minimum 1GB.
- g) SOLID STATE FLASH DRIVE: Minimum 120 GB
- h) Monitor: 21" colour VDU monitor
- i) I/O card: Adequate I/O facility, Controllers, network interface etc.
- j) Accessories: As required, if any.
- k) Environment: Operating temp = 0-55°C

ii) **FACILITIES WITH TERMINALS IN LOBBY**

- a) ON Line position of Crew with details of train and location.
- b) It shall be possible to change the names of Crew when prompted to do so by the Central Server.
- c) Daily print outs for planned (through) bookings and actual (through) bookings shall be possible.
- d) Monthly reports of Crew in terms of Kms and Duty Hours (individual date wise) shall be possible.
- e) Screen shall be menu driven with multiple windows.
- f) ON Line position of train positioning shall be available on request.
- g) The screens and the procedures shall be decided in consultation with the Engineer.
- h) It shall be possible to input Crew Booking details for next 24 Hours.
- i) At lobbies, normally the nomination of train wise Crew is decided in advance for the next twenty-four hours. It shall be possible to input information in advance, which shall be used at the appropriate time as per the timetable. Hence, normally when the system/ASM inputs a train number for the next departing train, the OCC shall link this information already input by the lobby and shall flash complete details on the screen at the lobby terminal. The lobby operator shall be able to change the data in case of any amendments. In case of no change, the displayed data shall be assumed correct.

iii) **FACILITIES WITH TERMINALS AT ELMD.**

- a) ON Line position of locos available at various sidings (station wise) shall be available.

- b) ON line position of locos in service at a particular time with train number and location details shall be available.
- c) ON Line position of loco movements earmarked for sending to ELMD shall be available. Details of locos earmarked for sending to ELMD shall be entered by Loco Controller.
- d) It shall be possible to query the Central Server at OCC
- e) It shall be able to generate reports on crew links, loco links, utilization of locos, crews and other related MIS reports. Formats of inputting information and reports shall be finalized in consultation with the Engineer.
- f) The screen shall be menu driven with multiple windows.
- g) It shall have a facility to view ON Line position of locos along with ON Line position of crew available on each train. These terminals shall have access to the database dealing with loco links and crew links and other related MIS reports.
- h) It shall be possible to send weekly schedule of Loco attachment/detachment from ELMD to OCC for its integration with the time table.

#### 10.6 Wiring

- i) The wiring shall be protected in PVC casing and capping. Cabling shall be structured one.
- ii) Where cables/wires are run under false floor, these will be supported on and tied to perforated cable trays.
- iii) All wiring shall be colour coded and shall have tags at the termination points showing the circuit number etc. for easy fault identification.

### 11. SOFTWARE

#### 11.1 General

**All desired features of application software are described in FRS. This shall be referred while designing software.**

- i) All software shall be based on open system concept, shall be modular and independent of type of processor or hardware platform.
- ii) It shall be based on co-operative or client server processing architecture with distributed processing logic.
- iii) It shall be 64 bit UNIX or Multitasking for OCC & suitable 64 bit operating system for field network and ORACLE /SQL/DB2 for database.
- iv) Security: The tenderer shall define the procedures to maintain the security of the system software. Aspects to be considered are:
  - a) Sabotage – The tenderer shall describe what measures shall be taken to protect the software against sabotage. This description shall define the physical restrictions as well as procedural measures and specific tests to be carried on the software.

- b) Unauthorized Access: The tenderer shall describe what measures are to be taken to protect the software against unauthorized access and subsequent modification. The description shall define physical & procedural methods.
- c) VIRUS: The tenderer shall ensure that software which is susceptible to virus is developed in environment certified free from computer viruses. To achieve this, the tenderer shall use proprietary virus detection and suppression tools as approved by the Engineer.
- v) It shall be menu driven & modular system.
- vi) All software shall be portable across similar operating systems.
- vii) The real time DBMS used for linking clients and servers shall keep at least two synchronized copies of all data bases to enable quick switch over to standby processes without loss of data (RAID 1 System). To achieve hardware tolerance at the main server, the disc controllers used for RAID systems shall be separate.
- viii) It shall be possible to access the same file by more than two users at the same time and information on such a file shall be active.
- ix) The database shall be stored in file structure for easy retrieval of the selected data.
- ix) It shall be possible to add minor additional functionality (in consultation with the Engineer) or even extend the system to more number of users by adding extra workstations without changing existing software.
- x) The modification /alteration shall be possible from the simulation terminal without any reference to source code. Menu driven tools shall be made available. To ensure that alterations /amendments are carried out as intended, the terminal operator shall confirm the amendments before inputting to system or saving on system. System shall prompt confirmation request with authority. All amendments shall be recorded with the authority.
- xi) As all data may not be available in a satisfactory format during the initial implementation of the system, it is necessary that provision exists for incorporating changes/amendments to the existing formats/presentation and for introduction of new functionality. It is possible that additional items/objects may have to be introduced in future.
- xii) Following modifications shall be possible without recourse to the source program (code).

a) MANAGING THE USERS

- Ability to add users specifying their names, password & access level.
- Facility to delete an existing user.
- Change the priorities allocated to users.
- Stop / provide access to any of the modules.
- Change areas of jurisdiction.

b) DATABASE MANAGEMENT

- Database administration
  - Edit database to change the names of locations, stations etc.
  - Change status of stations.
  - Introduce new stations.
  - Introduce new objects and delete existing objects.
  - Change details of objects.
  - Amend / alter geographical layout at stations and in between stations.
  - Change format of reports.
  - Introduce new reports.
  - Introduce/change/delete temporary speed restrictions.
- c) TIME TABLE MANAGEMENT:
- Cancel a train trip;
  - Insert an additional train trip;
  - Change the destination of a trip;
  - Change the departure time of a trip; and
  - Change the timetabled dwell time at any station for one Train or all Trains.
  - Change timings of existing trains.
  - Change the sequences of trains.
  - Change various particulars of trains.
  - Change the loco number vis-à-vis train number.
- d) SYSTEM MANAGEMENT:
- Change priorities of existing alarms.
  - Introduce new alarms with varying priorities.
  - Changing the details of any node.
  - Introduction of new nodes.
  - Changing the displays on maintainer's terminal.
  - Changing the printer / plotter parameters.
- e) TRAIN GRAPH DISPLAY
- Create, modify, and delete controlled area included in the train graph display.
  - Change the various colours allocated for various types of train loads.
  - Change x & y coordinate scales.
- xiii) Suitable protection against VIRUS shall be provided. Any bug found in the software during or after DLP shall be eliminated free of cost.
- xiv) Detailed documentation of application software shall be supplied.
- xv) All standard software supplied shall be licensed versions in the name of "DFCCIL" along with original latest documentation.
- xvi) All software for driving the overview mimic indication panel shall also be included.

- xvii) The software code details of Modules explicitly developed for DFCCIL shall be supplied along with full documentation. Details of each module shall be explained.
- xviii) OPEN CHARACTER: The application software shall be standard open in character and shall be able to run in multi-vendor environments.
- xix) COMPLETENESS OF INFORMATION: No information shall be transmitted unless all the information is entered or the operator has declared that he has input all the required information.

## 11.2 Event Log and Alarm System

- i) All important events (commands, indications, errors, system information etc.) shall be logged in a log SQL database for printing and analysis later on.
- ii) Log database shall be separated into 3 sections viz. system log, short term log & long term log. The time span of log depends on the size of database and intensity of log events.
- iii) Replay of Event log: The replay function shall show an historical flow of events that has occurred and recorded earlier in the TMS system, e.g. in connection with an accident or a fault.
- iv) When replay shall be started, the dynamic status for infrastructure, train number system pretest and alarm list as well as the pictures on the screen shall be initialized.
- v) TRAFFIC RELATED ALARMS: Vital traffic operator related alarms are:
  - a) Failure of any signalling gear in the entire section.
  - b) Route/(s) not released after passage of train.
  - c) Train not described alarm (ND Alarm).
  - d) If a train stands at an OFF signal for more than 2 minutes, it shall initiate an alarm. Any other unscheduled train stoppage shall also initiate an alarm.
  - e) Any unscheduled train detention in excess of 5 minutes time shall also initiate an alarm.
  - f) Hot Axle detector alarm (to be actuated from potential free contacts of relays provided by PE-6 contractor in SERs/OCC).User shall be able to select setting of time elapse (1-10 minutes) before actuation of alarm in items “d” and “e” above.
- vi) NETWORK RELATED ALARMS
  - a) All alarms not directly related to traffic operations shall be considered to be Network related alarms.
  - b) These shall be displayed on the maintainer's terminal only on which NMS is loaded.
  - c) These shall be arranged in priority levels in consultation with the Engineer.



- d) Failure of Network Communication / inability to access any of the nodes, defective terminals, hardware and software failures shall be flashed.

### 11.3 Software - Train Describer System

- i) All desired features of application software are described in FRS. This shall be referred while designing software.
- ii) The train describer system shall enable controllers to identify any train by means of unique number allocated to each train. The number shall follow a train automatically as it moves through the DFCCIL network.
- iii) The Train Nos. shall be displayed at their positions and shown on monitors and overview indication panels in control office.
- iv) The train description shall be entered either by an ASM at the originating station or an controller in the control office.
- v) Train Describer system shall also direct all traffic related alarms to respective controllers e.g. Signal failures to Signal Fault Controller, Track failures to Engineering Controller, Loco failures to Loco controller.

### 11.4 Software - Customization Tool

- i) The tool shall allow user to cater for changes in yard layout and to carry out the required changes in databases and graphic display of altered layout.
- ii) The tool shall facilitate user to generate new report from the available database.

### 11.5 Software - MIS Report Generation

- i) The system shall allow user to enter any free text tag to be associated with any train.
- ii) The system shall generate report for trains run late by prescribed reference.
- iii) Based on the events logged and the controller input, the system shall generate following reports:
  - a. Various Train control charts
  - b. Various Punctuality reports
  - c. Bad runner report
  - d. Actual Loco Link Report
  - e. Load Composition report
  - f. Loco Maintenance/overhauling reports.
  - g. Punctuality analysis report in suitable format. This may be daily, weekly or monthly as per prescribed format.
  - h. Analytical report of various unusual occurrences, i.e. signal failures, OHE break down, loco failure etc. This shall be generated on daily, weekly or monthly basis on prescribed format.
  - i. Analytical report of crew link/ utilization.
  - j. Analytical report on loco link/ utilization.
  - k. Total Combined Maintenance Blocks granted / refused along with locations, time blocked, time cleared.

- l. Sectional running time taken by train of any ID.
- m. Report of trains run late along with train nos., delayed time (at stations) etc.
- n. Difference between actual and scheduled running time in tabulated as well as in graphical form

#### 11.6 Software- Train Graph

- i) The system shall plot historical train graphs for analysis.
- ii) It shall plot time on X axis and stations on Y axis.
- iii) It shall be possible to show schedule time and the actual time in the same graph but with different colors.
- iv) It shall be possible to show different types of train loads in different colors.
- v) It shall be possible to select direction of train and day for which graph is to be plotted.
- vi) On clicking / selecting a particular train graph, it shall give complete information about the train details viz. train no, crew information, loco, load details etc.
- vii) Advance charting: In case controller defines the Combined Maintenance Block on particular line for particular time, system shall be able to prepare train graph showing advance/predictive movements of available trains in particular section in different colours.
- viii) It shall be possible to deduce average speed of trains between any two stations.

#### 11.7 Interactive Train Graph (Off Line)

- i) To plot the modified train graph in case of rescheduling of trains.
- ii) To alter the running time of any train interactively (pull or drag) to see the effect INSTANTLY. It shall be possible to see the effects of increase / decrease in running time on the train graphs.
- iii) To find out the effect of speed restrictions, increase in train speed, modification in the station stopping time, effect of a failure at a given station etc.
- iv) It shall be possible to deduce average speed of trains between any two stations.

#### 11.8 Simulation Studies Including Timetable Planning System (Off Line)

- i) Separate terminal shall be provided for simulation studies & Timetable Planning System purpose. The replay of log, time table editing, editing of train graph etc. shall be provided on this terminal.
- ii) It shall be possible to simulate and observe the effect of various parameters such as Maintenance block, Speed restrictions, Change in yard layouts etc. on sectional density (capacity) and to produce train graphs in pictorial or tabular form. Simulation of the effect of addition / deletion of a signal shall also be possible. The parameters shall be decided in consultation with the Engineer.

- iii) Simulation of train movements:- Train movement shall be simulated by occupying & releasing Axle Counter Track sections on sections in accordance with movement of trains. The replay of log with predefined begin & end time shall be possible.
- iv) The simulator shall work with the same data as the on line system or separate Master data can be kept on the system
- v) It shall be possible to carry out simulation in real time or in reduced / accelerated time scale.
- vi) Automatic recording and retrieval of train movements shall be possible.
- vii) The system shall be capable of simulating the existing time-table and compare it with actual running on periodic basis to create Management Information to identify any shortcomings in the system / time-table.
- viii) Time table compilation and Proving: A time table compilation and proving system shall be provided such that time tables can be compiled and tested off line and loaded directly to the System when ready.
- ix) The time table compilation and proving system shall enable the creation and modification of time tables through Simulation terminal.
- x) Modification of an active timetable shall be possible and such modifications shall take immediate effect.
- xi) Time table modifications shall remain effective until cancelled or until the end of the operating day, whichever is sooner. The modified timetable shall be saved separately from the reference timetable for future use and the reference timetable shall not be permanently changed by changes made in the above manner.
- xii) Time table Editor: The time table compilation and proving system shall provide an editor for editing inter station running times, station dwell times, terminus turnaround times and train description for each of the time table blocks (timetable periods) defined.
- xiii) Types of Trains in Time table: It will be suitable for all types of trains working on DFCCIL line.
- xiv) Generation of time table: The time table compilation and proving system shall generate the following different parts of the time tables;
  - a) Working time table;
  - b) Distances between stations and different sets of run time and dwell times;
  - c) Summary of train frequencies.
- xv) Plot Train Movements: The time table compilation and proving system shall plot train movements in the form of a time distance graph utilising a suitable colour scheme on A0 size graph as approved by the Engineer.
- xvi) Generate summary information: The time table compilation and proving system shall calculate and generate number of train trips and train kilometres for all time table trains.

#### 11.9 Software- Crew Management System (Off line)

- i) Crew management software system shall be provided for Loco Pilots of DFCCIL line.
- ii) Crew management details shall be fed by lobby staff separately for each Loco Pilot. The database will have all the information related to personnel & safety of Loco Pilots.
- iii) Software will prepare detailed link program based on data fed by lobby staff for Loco Pilots.
- iv) It shall be possible to change Loco Pilots booking details for next 24 Hrs.
- v) Daily report of planned booking and actual booking of crew shall be possible.
- vi) Monthly reports of Loco Pilots in terms of KMs & duty hours, individual date wise shall be possible based on real time data from TMS.
- vii) It shall be possible to calculate running allowance of crew based on real time data from TMS.

#### 11.10 Software – Automatic Route Setting (ARS)

System shall be capable for its provision in future.

#### 11.11 Stages of Development of Software

##### 11.11.1 Level of Bugs

Bugs found during various stages of software development shall be categorized as under:

**Blocker:**Block Development and/or testing work.

**Critical:**Crashes, loss of data, severe memory leak etc.

**Major:** Major loss of function.

**Minor:** Minor loss of function or other problem where easy workaround is present.

**Trivial:** Cosmetic Problem like misspelled words or misaligned text.

**Enhancement:**Request for enhancement.

##### 11.11.2 Software development stages:

- i) Story Boarding Stage: This delivery consists of submission of design documents in the form of storytelling. Document indicates various screens, transactions, queries and reports. Story boarding is intended to provide an early preview to the application and its sequential development. It would give an insight into navigational structure, look and feel of module. The story boarding document is to be approved by a committee of Engineer in charge, User and contractor. User can give large amount of inputs for improvement of the interfaces at this stage. All such improvements are to be incorporated in design document.
- ii) Alpha Stage: This stage pertains to development of software with limited database based on approved story telling document. This delivery consists of representative screens of masters and transactions, queries and reports. It is

intended to provide an early preview to the application and the screens at this stage are typically non-functional (mock up). It contains sample complex screens demonstrating unique navigational patterns. It would give an insight into navigational structure, look and feel of module. This stage is once again to be approved by a committee of Engineer in charge, User and contractor. User can give large amount of inputs for improvement of the interfaces at this stage. All such improvements are to be incorporated in Beta stage.

- iii) Beta Stage: In this stage, all the screens, processes and reports are developed and delivered. There may be Blocker and/or lower level bugs which may hamper testing in certain areas. Essentially, this stage is intended for testing by Engineer in charge through which contractor would get first round of feedback. Certain areas of application would still be in development stage at this point of time. Such areas would be listed out. There may be some known issues like performance etc., which would also be listed out. All such issues listed out would be covered in Gamma stage.
- iv) Gamma Stage: At this stage of delivery, all the development is over and all the issues listed in earlier stages are taken care of. There is no Blocker that can hamper test paths. However, there may be Critical or Lower level bugs which will be tracked to their closure in a structured way.
- v) Final Production ready stage: At this stage of delivery, all the bugs of the type BLOCKERS, CRITICAL, MAJOR and MINOR are taken care of. Any mutually agreed upon issues are also rectified. Thus, this delivery is the release for implementation. The trivial bugs will be taken up and corrected during implementation period.
- vi) Above stages are meant for customized development of software modules like: MIS reports, Crew management, decision support etc. Standard software modules like train describer, time tabling etc. can directly start from Alpha stage.

## **12. INTEGRATION WITH GSM(R) BASED MOBILE TRAIN RADIO SYSTEM**

- (i) A Mobile communication is being provided between the Loco Pilot & the Section Controller in OCC as a part of this contract.
- (ii) TMS system shall be integrated with GSM(R) based Mobile Train Radio Communication system.
- (iii) Suitable arrangement will be provided for entering of Train ID in Cab radio at the starting station of DFCCIL route and its confirmation from TMS by Radio Server. Details of the same shall require consent of the Engineer at Design stage.
- (iv) NOT USED.

## **13. SPARES**

The tenderer shall submit a list of recommended spares along with their costs which shall be required to be stocked for proper upkeep of the system. However, following guidelines shall be followed while preparing this list.

- i) SPARES FOR Electronic Cards/ Modules: As specified in Chapter 13 of Vol. III of Bid Documents.
- ii) SPARES FOR TERMINALS: Complete Terminals including VDU shall be supplied as spare. Quantity of the same shall be 10% of total supplied terminals subject to minimum 1 (one) of each type.

#### **14. DOCUMENTATION**

The manufacturer shall supply the following sets of documents. Guidelines contained in GS and PS on documentation shall be followed.

- 14.1 User manual: This Manual is meant for users of TMS explaining basic operation of data entry, data recording, generation of reports etc.
- 14.2 Operator manual: This manual is meant for System operator, who manages the system, controls individual operators, generates authorization, and supervises the functioning of system.
- 14.3 Programming manual: This manual is meant for Technical staff and will be used for programming the changes in display, incorporating changes in name of station, yard layout change, adding and deletion of new station, addition and deletion of new controllers etc.
- 14.4 Service/trouble shooting Manual: This manual is meant for technical staff and will be used to attend the various failures and troubleshoot the fault. The manual shall guide step by step to arrive at the exact fault.
- 14.5 Maintenance cum Technical manual: This manual is meant for technical staff and guides step by step for carrying out the various periodical & preventive maintenance checks and backups to be taken to prevent loss of data/software.
- 14.6 Schematic installation drawings: These drawings indicate the various arrangements of TMS like various controller terminals, it's layout, inter connections of the terminals, arrangement of LAN, configuration of equipment, the equipment installed at various locations etc.
- 14.7 Installation, operation & maintenance manuals: These shall be supplied as per details given in GS/PS.

#### **15. TRAINING & TRAINING DOCUMENTS/GADGETS**

Training shall be imparted to DFCCIL officials as per details given in GS/PS.

## ANNEXURE – A to Annexure 2

### **BASIC APPLICATION DATA INPUT TO THE SYSTEM**

#### **A Fixed Data**

- i) Working Time Table
- ii) Geographical data (station layouts along with signalling arrangements, crossovers / points, gates, tracks, signals etc.)
- iii) Loco Pilot booking schedule (sets)
- iv) Any other data prescribed by the Employer.

#### **B On Line Data Input**

This shall be collected automatically by the TMS system from various interlocking, Auto Location huts, Level crossing gates etc. on real time basis and shall include but not limited to the following:

- Status of main signals (G/YY, Y, R, Flashing);
- Shunt signals;
- Calling-ON signals;
- A-Marker status;
- Points set in Normal and reverse;
- Points failure indication in both Normal and Reverse;
- Points Health Monitoring output;
- Crank Handle IN/OUT status;
- Route set / release by passage of train;
- Axle Counter clear/occupied/error;
- All relays picked up / dropped status;
- Any mismatch between output of Electronic Interlocking (EI) and corresponding relay e.g. EI keeping the output for relay dropped but Relay picking up;
- Level crossing gate in open / closed position etc.
- PSS
- ELD
- All types of alarms
- Opening / closing of Signal equipment room and Auto Location Hut doors.
- Status of Air Conditioning at Porta cabins.

Note: Main and Supervisory Axle Counters provided in redundancy shall be monitored independent of each other.

#### **C Train Identification Information**

- a. Train No.
  - b. Destination
  - c. Platform No.
  - d. Name of Loco Pilot.
  - e. Type of load e.g. Container, Food grain etc.
  - f. Any special features.
- 
- i) Above information is to be keyed in by the train originating station ASM, manually from his terminal.

- ii) Generally complete information shall be required to be keyed in once only when load enters in the system (either from Electric Loco Maintenance ELMD / sidings / or other entry points) for the first time. Thereafter, system will display all the information. ASM will only be required to confirm the same and modify if required.
- iii) Train identification information shall be keyed in by the Section Controller in case concerned ASM has not done so.

#### **D Loco Pilot Booking Details**

- i) This shall be manually keyed in by Crew controller at designated Lobby (or at any other crew booking point) on his terminal during night time for next 24 hours.
- ii) Deviation for the booking schedules shall be entered by Crew controller on train to train basis.

#### **E Data to be keyed in by Section Controller**

- i) Train identification on getting NDA alarm (if not entered by concerned ASM);
- ii) Remark & cause for any unusual incident;
- iii) Selection of trains in case of cancellation;
- iv) Messages / Information for Panel ASMs for diversion / cancellation of trains;
- v) Message / Information will draw attention of ASM by flashing audiovisual indication;
- vi) Manipulation in train graphs for decision making.

#### **F Interrogation Input from Wayside Terminals**

The station ASM shall be able to interrogate the Central Server for any train related / siding occupancy queries.

#### **G Loco Controller**

- i) Normally system shall automatically update position of loads in various sidings. However, facility shall be provided to ASM terminals to enter the details / occupancy of sidings in station yards.
- ii) Loco controller shall input the details of locos identified for withdrawing and sending to ELMD for maintenance and repair including planned movement. This information shall be normally keyed in twice a day in respect of the locos to be withdrawn.

#### **H Other Controllers (Signal, Engg., TPC, etc.)**

They shall input remarks / information pertaining to various unusual occurrences e.g. failures & delays to operation etc.



NOTE: Application Data input mentioned above is to be finalized in consultation with the Engineer after award of contract.

\* \* \* End of Annexure 2 \* \* \*

(Please see conceptual system sketch on next page)

Fig.-1

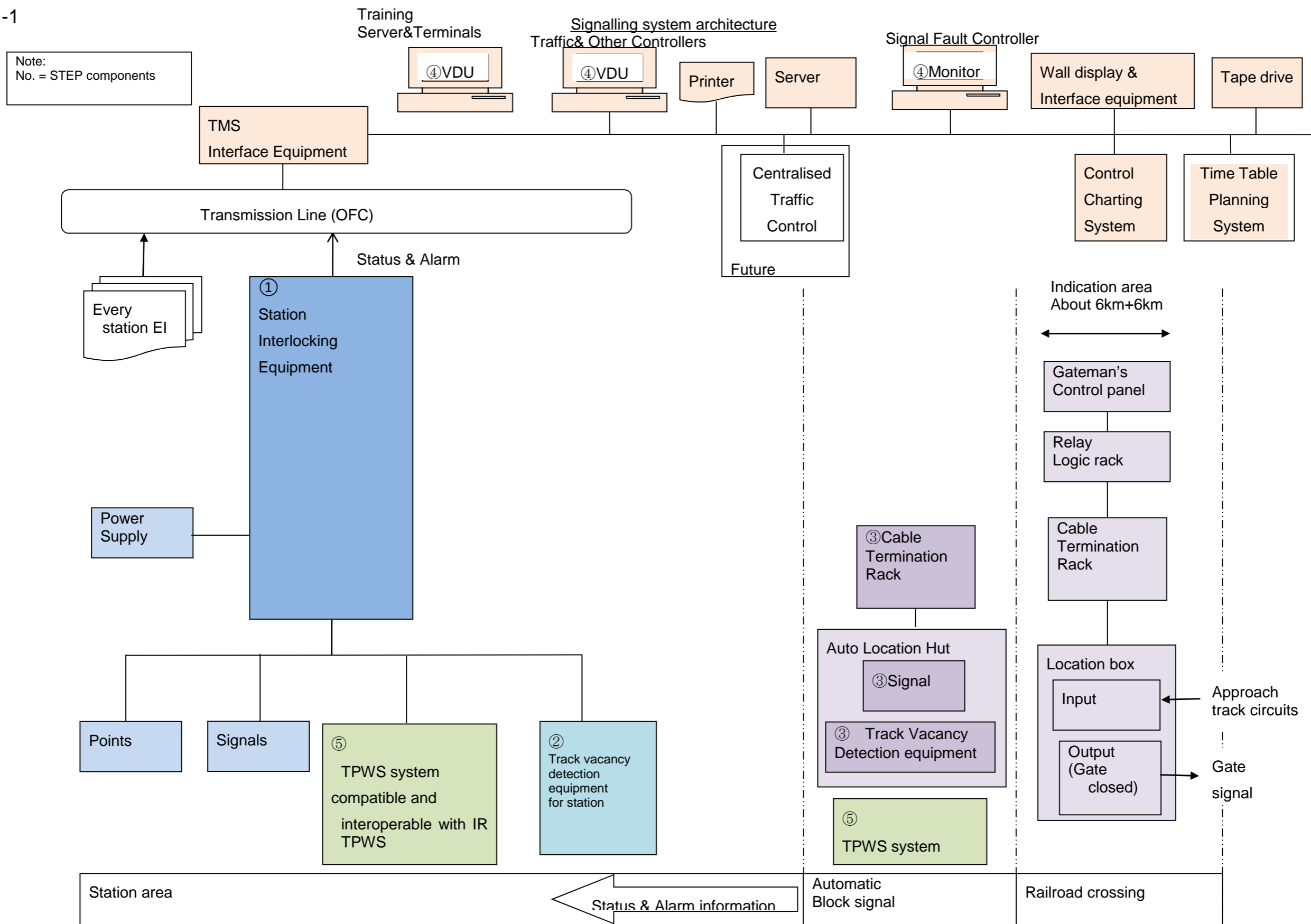

### Annexure 3: List of Junction and Crossing Stations

(Junction Stations shown in Bold)

Phase 1 Stations (JS-10, CS-21)		Inter Stn distance Kms)	
1	<b>MAKARPURA JN</b>	0	P3 (289 Km)
2	VASAD	35	
3	CHANGA CS	28	
4	TIMBA CS	42	
5	<b>SABARMATI SOUTH</b>	23	
6	<b>SABARMATI NORTH</b>	10	
7	Ghumasan	31	
8	<b>MAHESANA JN</b>	41	
9	Malosan	42	
10	<b>PALANPUR JN</b>	19	
11	Chadotar	11	
12	Shri Amirgarh	26	P2 (284 Km)
13	Swarupganj	39	
14	Banas	12	
15	Keshavganj	18	
16	Biroliya	40	
17	Jawali	34	
18	<b>Marwar</b>	36	
19	Chandawal	36	
20	Haripur	19	
21	<b>Bangurgram</b>	41	
22	Sardhana	36	
23	Kishangarh	28	P1 (342 Km)
24	Sakhun	34	
25	<b>Phulera</b>	19	
26	PacharMalikpur	48	
27	Shri Madhopur	24	
28	Baghegha	37	
29	Dabla	35	
30	<b>Ateli</b>	32	
31	<b>Rewari</b>	35	

	Phase 2 Stations (JS-3, CS-9)	Inter Stn distance Kms)	
<b>JS1</b>	<b>JNPT</b>	<b>0</b>	P11 (102 kms) JNPT - Vaitarna
CS1	Nilje	38	
<b>JS2</b>	<b>Kharbao</b>	<b>34</b>	P12 (186 kms) Vaitarna- Sachin
CS2	safale	34	
CS3	Palghar	34	
CS4	Gholvad	40	
CS5	Pardi	40	
CS6	Ancheli	38	
<b>JS3</b>	<b>New Udhna</b>	<b>40</b>	P13 (134 kms) Sachin- Makarpura
CS7	Gothangam	17	
CS8	Sanjali	39	
CS9	Varedia	28	
<b>Total JNPT-Makarpura</b>			<b>422 Kms</b>

\*\*\* End of Annexure 3 \*\*\*

**Annexure 4: Typical Signalling Plan of Depot  
(Note: Attached separately)**

\* \* \* End of Annexure 4 \* \* \*

ANNEXURE 5: CHAPTER XIV OF IRSEM - SAFETY DEVICES TO BE PROVIDED AT L.C. GATES

Chapter XIV of Indian Railway Signal Engineering Manual (IRSEM) Part-II (Annexure 10-Revised)						
Comprehensive Policy on Provision of Safety Devices at Level Crossings						
	Spl. Class	A class	B1 class	B2 class	C class (Manned)	Other Stipulations
TVU -->	>50000	>30000 and <50000	>25000 and <30000	>20000 and <25000	>3000 Cat I & >2500 Cat II	
<b>1. Interlocking of Gates with Signals.</b>						
a) Within Station Limits	Should be Interlocked with Station Signals	Should be Interlocked with Station Signals	Should be Interlocked with Station Signals	Should be Interlocked with Station Signals	Should be Interlocked with Station Signals in Suburban Section, in Automatic Block Signalling. In Non-suburban section, it should be Interlocked with Station Signals, if the LC Gate is operated from the nearest Cabin or if it has to be interlocked for any other reason irrespective of the place of operation.	To minimize the Mean Waiting Time for road users, the arrangement of Interlocking should be such that the last operation before taking 'OFF' of Signal should be the closing of the Gate and the first operation after the train has cleared the Level Crossing and the Signal is put back to 'ON' position, should be opening of the Gate by the Gateman.
(b) Outside Station Limits	Should be Interlocked with Gate Signals	Should be Interlocked with Gate Signals	Should be Interlocked with Gate Signals	Should be Interlocked with Gate Signals	Should be Interlocked with Gate Signals in Automatic Block Signalling Sections.	i) In case of level crossing protected by signal, where the sighting of the signal by an engine driver is inadequate and the Gate signal is not pre-warned through other means ( Distant Signal / Independent Warner Signal / Repeater Signal etc.), a Warning Board should be placed at not less than the emergency braking distance in the rear of the Gate Stop Signal. The board should be vertical 2000 mm by 450 mm with alternate black and yellow strips 125 mm width painted on

Chapter XIV of Indian Railway Signal Engineering Manual (IRSEM) Part-II (Annexure 10-Revised)						
Comprehensive Policy on Provision of Safety Devices at Level Crossings						
	Spl. Class	A class	B1 class	B2 class	C class (Manned)	Other Stipulations
TVU -->	>50000	>30000 and <50000	>25000 and <30000	>20000 and <25000	>3000 Cat I & >2500 Cat II	
						it at an angle of 45 degree. The top of the board should be 4 M above rail level. The board need not be lit at night but should as far as possible be provided with scotchlite or other effective light reflectors or retro-reflective tape. ii) Where level crossing is situated outside station limits but in close proximity thereof, the clear distance between the level crossing and an outer signal should not be less than the full train length.
Note: All manned level crossing gates both within and outside station limits falling on suburban sections and Automatic Block Signalling section shall be interlocked irrespective of the classification / TVUs of the gates.						
c) Normal Position of Gate	Shall be normally kept open to Road Traffic				If Interlocked, shall be normally kept open to Road Traffic.	
Chapter XIV of Indian Railway Signal Engineering Manual (IRSEM) Part-II (Annexure 10-Revised)						
Comprehensive Policy on Provision of Safety Devices at Level Crossings						
						Year 2010
	Spl. Class	A class	B1 class	B2 class	C class (Manned)	Other Stipulations

<b>Chapter XIV of Indian Railway Signal Engineering Manual (IRSEM) Part-II (Annexure 10-Revised)</b>						
<b>Comprehensive Policy on Provision of Safety Devices at Level Crossings</b>						
	<b>Spl. Class</b>	<b>A class</b>	<b>B1 class</b>	<b>B2 class</b>	<b>C class (Manned)</b>	<b>Other Stipulations</b>
TVU -->	>50000	>30000 and <50000	>25000 and <30000	>20000 and <25000	>3000 Cat I &>2500 Cat II	
TVU -->	>50000	>30000 and <50000	>25000 and <30000	>20000 and <25000	>3000 Cat I &>2500 Cat II	
<b>2. Telephonic Communication from the Gate Lodge.</b>						
Within or Outside Station Limits	Telephone be provided with ASM's office with <b>all Manned</b> Level Crossing Gates.					In Block Sections having large number of Level Crossing Gates, the connections should be uniformly distributed between the Block Stations.
<b>3. Warning Bells or Hooters Operated by Approaching Train.</b>						
Within or Outside Station Limits	Should be provided.	Should be provided.	Should be provided.	Should be provided.	Should be provided, where Level Crossing is Outside the Station limits in all Suburban Sections and Non-suburban Sections provided with Automatic Block Signalling Territories.	Provision of warning bells operated by Approaching Trains should be confined to Interlocked Level Crossing Gates only. Hooters shall be provided, where ever power supply is available.
<b>4. Type of Lifting barrier</b>						
a) Within or Outside Station Limits	Electrically Operated Lifting barrier.	Electrically Operated Lifting barrier.	Electrically Operated Lifting barrier.	Electrically Operated Lifting barrier.	Electrically Operated Lifting Barrier in Sub-urban Section.	In Non -suburban Section, Electrically Operated Lifting Barrier be provided, where Power Supply is Reliable.
<b>5. Approach Locking</b>						



Chapter XIV of Indian Railway Signal Engineering Manual (IRSEM) Part-II (Annexure 10-Revised)						
Comprehensive Policy on Provision of Safety Devices at Level Crossings						
	Spl. Class	A class	B1 class	B2 class	C class (Manned)	Other Stipulations
TVU -->	>50000	>30000 and <50000	>25000 and <30000	>20000 and <25000	>3000 Cat I &>2500 Cat II	
	(i) To be provided in Sub-urban Section. (ii) Dead Approach Locking with Timing of 30secs in other sections.			(i) To be provided in Sub-urban Section. (ii) Dead Approach Locking with Timing of 30secs in other sections, where Electrically Operated Lifting Barriers are provided.		

\*\*\* End of Annexure 5 \*\*\*

## **ANNEXURE 6: POLICY OF TRAIN OPERATION PLANNING ON WDFC**

### **1. PURPOSE**

1.1 The train operation plan is a base of DFC system including station layout & railway systems.

### **2. INTRODUCTION**

2.1 Network of the Western Corridor includes DFC line and feeder lines operated by IR. It is most important to clarify the policy of train operation planning for trains on DFC only and trains interoperated on DFC and IR lines.

### **3. DISCUSSION**

#### **3.1 Traffic**

- (1) Block Working between IR station to DFC station at junctions.
- (2) There should not be any surface crossing for train between IR & DFC excepting Banas, Keshavganj and Bangurgram for cement plant sidings and at Marwar.
- (3) Freight trains on IR, for which DFC would provide the most logical (shortest and/or fastest) route to be assigned to DFC, provided they cross 2 or more consecutive junction stations over the DFC.
- (4) Time table running of goods trains on DFC – normally trains to run on charted paths only including premier path.
- (5) Number and location of crew changing stations - should be **at an interval of 500kms**. The interval is calculated for less than 8 hour running time assuming average speed 65kmph. The booked speed of trains will be 80 kmph and maximum permissible speed is 100 kmph. The target time of crew change is assumed as 10 minutes at the station.
- (6) Issue of crew owned by DFCCIL will be examined further.
- (7) Double Stack Container(DSC) train with well type wagons and Single Stack Container train will run from the beginning.
- (8) The projected level of traffic on Western Corridor is over 130 trains for 2021-2022 onwards **which calls for long haul operations**. Long haul trains will be required to be run from the very beginning for minimising adverse effects of signal/rolling stock failures, rail fractures, breakdowns, accidents, etc. Intermediate Starter signals should be provided on long loops (1500m CSRs) to start with at Junction stations and subsequently at Crossing (roadside) stations. Distributed power system (Locotroll) should be introduced for long haul operation from the beginning.
- (9) Trains will run with End of Train Telemetry (EOTT) or Last Vehicle Detection (LVD) without Brake Vans (BVs).  
Trains should run with EOTT/LVD, from the very beginning, at least on selected feeder routes of Phulera, Palanpur, Marwar Jn., Mehsana, Sabarmati, Dahej/Hazira ports, Mumbai area and JNPT.
- (10) Diesel Locos should be changed at junction stations of DFC. No diesel fuelling station is required. However, electric locos of IR with high rise panto having adequate power and having its destination within 150-200km, entering WDFC may not be changed. Otherwise locomotive will be changed at Junction station. Feeder routes in western coast should be progressively electrified.
- (11) Last loop at junction stations need not have facilities for handling Container trains/Rail Runners in the beginning. The same will be developed as and when required.

- (12) Movement chart will be prepared by the computers. Therefore, daily moving charts may be prepared incorporating temporary speed restrictions imposed by P/W engineers. Copies should be made available at originating stations of feeder routes and junction stations on DFC.
- (13) If Phase II does not come simultaneously with Phase I, phase working at Makarpura Jn. station should enable dispatching to and receiving trains from IR. Similarly, if the Eastern and Western Corridors of DFC do not come simultaneously, phase working plan should be prepared for transfer of trains between Eastern and Western Corridor via IR route and Eastern/ Western Corridor and IR.

### 3.2 Civil Engineering

- (1) CSRs of the loops should be 1500m. All junction stations on DFC to be provided with 1500m (CSR) loops from the beginning. Loops at crossing (roadside) stations will initially be 750m (CSR) long which will be extended to 1500m (CSR) at a later date.
- (2) The decision was made to adopt 1 in 12 turnouts to save space. There is need to take maximum speed potential of 50kmph on these turnouts.
- (3) It was decided to provide 4 hours Corridor Maintenance Block (CMB) for 6 days in a week normally, 3 days in the UP direction and 3 days in the DN direction.
- (4) All scheduled/preventive etc. maintenance including ballast trailing/unloading to be undertaken during CMB.
- (5) Number and location of Integrated Maintenance Depots (IMDs):
- (a) IMDs cover approximately 160kms. Sub-depots are proposed at stations approximately at 80 kms. interval.
- (b) OHE and S&T depots should be located at IMDs.

The present depots allocation plan is as below.

Table: **List of IMDs & Sub-Depots in Rewari-Makarpura-JNPT sections**

	Phase I Stations (JS-10, CS-21)		
(Junction Stations shown in Bold)		IMD	Sub-Depot
<b>1</b>	<b>MAKARPURA JN</b>	√	
2	VASAD		√
3	CHANGA CS		√
4	TIMBA CS		√
<b>5</b>	<b>SABARMATI SOUTH</b>	√	
6	<b>SABARMATI NORTH</b>		
<b>7</b>	Ghumasan		√
8	<b>MAHESANA JN</b>		√
<b>9</b>	Malosan		√
10	<b>PALANPUR JN</b>	√	
11	Chadotar		
12	Shri Amirgarh		√

13	Swarupganj		√
14	Banas		
15	Keshavganj	√	
16	Biroliya		√
17	Jawali		√
18	<b>Marwar</b>	√	
19	Chandawal		√
20	Haripur		√
21	<b>Bangurgram</b>		√
22	Sardhana	√	√
23	Kishangarh		√
24	Sakhun		√
25	<b>Phulera</b>		
26	Pachar Malikpur		√
27	Shri Madhopur	√	
28	Baghegha		√
29	Dabla		√
30	<b>Ateli</b>		√
31	<b>Rewari</b>	√	

--	--	--	--	--	--	--	--

Note: Chainages of DFC are temporary. Chainages of IR line are that of nearest station for reference.

- (6) Ballast depots should work round the clock. The ballast train should run preferably at maximum permissible speed of 100kmph. If it is less than 100kmph, it will run and work only during Corridor Maintenance Block.
- (7) Maximum running speed of Ultrasound Testing Vehicle, Track Recording Car should be 100kmph. Working speeds of Ultrasound Testing Vehicle, Rail Grinding train, Ballast Cleaning machine, Track Machines etc. being less than 100kmph should work during CMB.
- (8) C&W maintenance will be entirely IR's responsibility.
- (9) Substructure, formation including embankment and cut, and bridges to be planned for 32.5t axle load. However, initially track will be planned for 25t axle load.

### 3.3 Safety

- (1) Level Crossing (LX) Gates with more than 25,000 TVU will have either ROBs or RUBs. LXs with less than 25,000 TVUs will be interlocked in such a way that normally these will be closed to road traffic. Only a single set of road barriers to be provided covering both IR and DFC tracks and the same would be operated by gateman of IR. To facilitate opening of gates, occupancy of Axle Counter Track sections on either side of the Level crossing should be displayed in the goomty of IR's gateman.
- (2) DFCCIL will also have separate General Rule (GR) & Special Rule (SR) and since only goods trains will run on DFC, MD/Director Project/Director Infrastructure, DFCCIL will be empowered to open new lines/sections
- (3) DFCCIL will be authorised to issue SR, Operations Manual, Working Time Table, Rules for Abnormal Working etc.

### 3.4 Mechanical Engineering

- (1) At present Accident Relief Trains (ARTs)/Breakdown Cranes will be provided at Sabarmati (South) and Sardana. IR's breakdown cranes and ARTs should be used wherever possible.
- (2) DFCCIL's ARTs are planned as under:

(i)	140t breakdown crane and ART	Sabarmati (South) and Sardana
(ii)	Road-cum-Rail ART with hydraulic jacking system	Rewari, JNPT

The help from adjacent IR network will be available for attending emergency.

(3) Number and location of rolling stock monitoring facilities:

Hot box detector & wheel impact detector should be at the entrance of every important junction station. The final decision has not yet been taken. The decision will be made after discussions with MOR and after cost details are studied. Consultants strongly advise that the hot box detectors should be spaced every 30 to 50km, or not used at all, as greater spacing will not be effective in detection of hot bearings and derailment prevention.

(4) Hot axle sidings may be provided at the alternate stations.

3.5 Traffic and S&T

(1) TPWS should be provided from the beginning.

(2) OCC Building is planned in or around Ahmedabad city.

(3) Points and signals will be operated by station masters locally. (Route control will be done at every station.) However, provisions for centralised traffic control in future should be made.

(4) Multi Modal Logistic Parks (MMLPs) are proposed to be located at New Mumbai, Ahmedabad area and Rewari on Western Corridor.

(5) For working/ running track machines, cranes/ART during accidents etc., shunt signals provided should be used for wrong line movement through emergency crossovers.

(6) For combining two trains into "Long Haul" and breaking a Long Haul train into two single trains, "Intermediate starter signal" should be provided on 1500m (CSR) long loops having intermediate crossovers.

(7) Crew headquartered at Makarpura will work trains between Makarpura and JNPT/ Kharbao and Hazira (or Gottangaon). The same crew and Loco may ideally work trains right up to Hazira and Dahej ports. Similarly Makarpura and Marwar based crews will work trains between Makarpura and Marwar. Therefore, both Makarpura and Marwar will have quarters as well as running rooms for crew. Crews based at Marwar and Rewari will work trains between Marwar and Rewari.

(8) It may be decided whether IR or DFC crew should work trains from Rewari to ICDs in NCR and back. Trains coming from or going to Mundra and Kandla ports should be run by Palanpur and Phulera based crews. These trains between Phulera and up to the ICDs in NCR and back may be worked by Phulera based crews.

3.6 Electrical Engineering

(1) The high rise pantographs will be fitted with locos running on feeder routes. They are already procured and being installed by IR.

(2) Transition section of OHE height 5.5m/7.45m will be installed at entrance of the junction stations.

3.8 Electric locomotive shed is planned at Rewari.

- \* \* \* End of Annexure 6 \* \* \*

## **ANNEXURE 7-1: PHYSICAL INTERFACE BETWEEN EM P-4 / EM P-16 & ST P-5A – SPECIFIC ISSUES**

### **1. INTRODUCTION**

#### **1.1 Definitions and Scope**

- 1.1.1 This annexure covers the interface requirements between ST P-5A Contractor and EM P-4/ EM P-16 Contractors.
- 1.1.2 In this annexure, unless otherwise stated, the term “Contracts” refers to each of the ST P-5A and EM P-4 / EM P-16 contracts and the term “Contractors” refers to each of the ST P-5A and EM P-4/ EM P-16 Contractors. The individual Contractor is referred to by the corresponding contract number.

### **2. Contractors' Responsibilities**

- 2.1 The EM P-4 / EM P-16 Contractors shall provide the ST P-5A contractor with the location and numbering of all OHE masts, TSS, SP and SSP.
- 2.2 The Contractors shall co-ordinate for ensuring the minimum safe distance between any TPWS field installation and the live OHE contact point for the purpose of human safety apart from EMI/EMC considerations being as per SOD of DFCCIL for Western Corridor.
- 2.3 a) EM P-4 / EM P-16 Contractors shall develop Project wide Earthing and Bonding Management Plan. ST P-5A Contractor shall coordinate and provide earthing system accordingly as per International practice.
- b) Extension of Traction Earth from the agreed track side connection point to TPWS equipment shall be done by ST P-5A Contractor as per agreed system of Earthing Management Plan.
- c) EM P-4 / EM P-16 Contractors shall be connecting OHE masts and rails to Traction Earth.

### **3. ELECTRICAL INTERFACE**

#### **3.1 General:**

3.1.1 The overriding principle to be employed on the Project is safety by Design. No person shall be exposed to accessible voltage that exceeds the levels of International Standards, under normal operations or fault conditions.

### **3.2 Traction Return**

3.2.1 The ST P-5A Contractor shall advise the EM P-4 / EM P-16 Contractors of the location of the Balise required by the TPWS system.

3.2.2 P-4 / EM P-16 contractors shall prepare Bonding Plan showing location of the Balise and proposed Traction Return Bonds and Cross bonds keeping required spacing from Balise. Each of the Contractors shall agree on the final location of these bonds.

3.2.3 EMP-4 / EM P-16 Contractors shall advise the locations of all Auto Transformers on the line. These locations shall be at all TSS, SP, SSP and at all other AT locations.

3.2.4 The EM P-4 / EM P-16 Contractors shall supply, install and terminate bonding cables.

3.2.5 For connecting the return current cables from the auto transformers and at TSSs to the running rails, EM P-4 / EM P-16 Contractors shall co-ordinate with ST P-5A contractor. The terminations of cables shall be agreed by each of the Contractors.

3.2.6 EM P-4 / EM P-16 Contractors shall co-ordinate with ST P-5A Contractor to determine the actual locations of cross bonding cable connections. The length of cross-bonds shall be kept as short as possible.

### **3.3 NOT USED**

### **3.4 NOT USED**

### **4. Location of Neutral Section**

4.1 The EM P-4 / EM P-16 Contractors shall provide the ST P-5A Contractor with the location of all neutral sections in order to ensure that location of Balise are adjusted to ensure coasting of locomotive while negotiating neutral section.

4.2 The ST P-5A Contractor shall design the TPWS system such that no locomotive or a part of a locomotive stops within the neutral sections during normal operations.

### **5. SCOPE OF SUPPLY**

#### **5.1 Scope of the ST P-5A Contract**



The ST P-5A Contractor shall provide and install all equipment necessary to ensure correct operation of the TPWS system in respect of system requirements of EM P-4 / EM P-16 Contractors.

## **5.2 Scope of the EM P-4 / EM P-16 Contract**

- 5.2.1 The EM P-4 / EM P-16 Contractors shall supply, install and terminate bonding cables from rail to earth and from rail to rail including the provision of earth & necessary accessories for fixing and terminating the bonding cables.
- 5.2.2 The EM P-4 / EM P-16 Contractors shall provide physical details of the OHE masts and their locations including GPS mapping of all the masts and clearly indicate OHE mast location number with corresponding co-ordinates.

\* \* \* End of Appendix 7-1 \* \* \*

## **ANNEXURE 7-2: PHYSICAL INTERFACE BETWEEN RS P-7 & ST P-5A: SPECIFIC ISSUES**

### **1. INTERFACES**

Interfaces between RS P-7 and ST P-5A Contracts shall include but shall not be limited to the items included in interface matrix below.

"Annexure '7-2' Cont."

S.No.	ITEM OF WORK	ST P-5	ST P-5A	RS P-7
1.	Track side Signalling and TPWS systems	<p>(i) Shall install Signalling and interlocking system upto Ch. 14.449 (i.e up to main entry / exit point of the ELMD) and up to Ch. 15.320 on the DFC Main Line where the emergency entry / exit of ELMD meets the DFC Main Line.</p> <p>(ii) Furnish information on vendors of Signalling equipment to RS P-7.</p> <p>(iii) Interface with RS P-7 for Entry/Exit signals at both the entry / exits of ELMD.</p> <p>(iv) Provide interference current limits to RS P-7 and test the same.</p>	<p>(i) Provide details of power supply requirements for TPWS on Test Track to RS P-7.</p> <p>(ii) Provide TPWS on the test track.</p> <p>(iii) Interface with RS P-7 for provision of TPWS on Entry/Exit signals at both the entry / exits of ELMD.</p> <p>(iv) Provide interference current limits to RS P-7 and test the same.</p>	<p>(i) Design and Build signalling and interlocking system in the depot as per Particular Specification of Signals and interlocking system.</p> <p>(ii) All the Signalling equipment shall be obtained from vendors approved for STP-5 contractor.</p> <p>(iii) Provide detailed track layout plan of Depot entry track at locations of entry / exits of ELMD to STP-5 Contractor.</p> <p>(iv) Provide detailed track layout plan of Depot entry track at both the locations of entry / exits of ELMD &amp; Test Track to STP-5A Contractor.</p> <p>(v) Provide rooms for TPWS maintenance and store room including lights, fans, Air Conditioning, computer table, tables, chairs, cupboards etc.</p> <p>(vi) Interface with ST P-5 for ELMD Entry/Exit signals at both the locations of entry / exit.</p> <p>(vii) Ensure that interference currents are within limits. Associate in its measurement by STP-5 and ST P-5A.</p> <p>(viii) Provide Depot Radio and EPABX communication to TPWS maintenance staff.</p>
2.	On Board - TPWS system	xx	<p>(i) Provide space requirements to RS P-7 for fixing On-Board TPWS equipment (cabinet, DMI, Antenna, Axle mounted odometer etc.) in the Locomotive.</p> <p>(ii) Supply all On-Board TPWS equipment and those special</p>	<p>(i) Provide required space to STP-5A for fixing On-Board TPWS equipment in the Locomotive.</p> <p>(ii) Except connections to the On Board equipment supplied by STP-5A, all cables and associated terminals and electrical</p>

S.No.	ITEM OF WORK	ST P-5	ST P-5A	RS P-7
			<p>electrical cables and the associated terminals, including plugs and sockets that are directly connected.</p> <p>(iii) Provide details of power supply requirements for On-Board TPWS equipment to RS P-7.</p> <p>(iv) Train RS P-7 staff for fitting and carrying out preliminary testing of On-Board TPWS equipment during Loco manufacturing.</p> <p>(v) Provide Braking interface from TPWS to Locos.</p> <p>(vi) Carry out compatibility testing of TPWS with IR's TPWS.</p> <p>(vii) Carry out full testing of On-Board TPWS equipment provided on every Loco jointly with RS P-7.</p> <p>(viii) Provide TPWS data input to ST P-7 for Driver's simulator.</p>	<p>connections for the On Board equipment shall be provided by RS P-7.</p> <p>(iii) Fix and wire all On-Board TPWS equipment in the Locos in accordance with the requirement of ST P-5A.</p> <p>(iv) Provide required power supply for On-Board TPWS equipment to STP5A.</p> <p>(v) Provide Braking interface to TPWS.</p> <p>(vi) Associate with STP-5A for carrying out compatibility testing of WDFC TPWS with IR's TPWS.</p> <p>(vii) Associate with STP5A for carrying out full testing of On-Board WDFC TPWS equipment provided on every loco.</p> <p>(viii) Ensure that the locomotives data communications protocols are fully compatible with RS P-5A supplied on-board equipment.</p>

\* \* \* End of Appendix 7-2 \* \* \*

**ANNEXURE 7-3: PHYSICAL INTERFACE ISSUES BETWEEN ST P-5A & Civil works contractors**

CT P-1	Civil/Building/Track Works Rewari – Ajmer Section;
CT P-2	Civil/Building/Track Works Ajmer –Ikbargarh Section;
CT P-3	Civil/Building/Track Works Ikbargarh – Vadodara Section (excluding bridges across river Mahi and Sabarmati);
CT P-3A	Steel Bridges across rivers Mahi and Sabarmati;
CT P-11	Civil, Building and Track Works (JNPT - Vaitarana)
CT P-12	Civil, Building and Track Works (Vaitarana - Sachin)
CT P-13	Civil, Building and Track Works (Sachin - Vadodara)
CT P-15A	Special Steel Bridges in JNPT - Vadodara Section
CT P-15B	Special Steel Bridge across Narmada River

hereinafter referred to as 'Civil Works Contractors'.

**1. Definitions and Scope**

- 1.1 This Appendix shall be read in conjunction with the relevant clauses of the Particular Specification. Each of the ST P-5A Contractor and Civil/Building/Track Works/Special Steel Bridge Contractors shall be responsible for ensuring that all requirements of the GS pertaining to interfaces are properly satisfied.
- 1.2 Notwithstanding the requirements described elsewhere in the Contract regarding the precedence of documents, the provisions contained in the Particular Specifications and Reference Drawings shall prevail over the provisions contained in this Interface Specification.
- 1.3 This Appendix outlines Interface requirements during the execution of the Works. However, the requirements herein specified are only indicative and it remains the responsibility of ST P-5A and Civil Works Contractors to develop update and execute

jointly an Interface Management Plan during the currency of the respective Contracts to ensure that

- (1) all interface issues between Civil/Building/Track Works/Special Steel Bridge Contractors and the ST P-5A Contractor are satisfactorily identified and resolved;
- (2) All construction tolerances at the interface shall meet the requirements of the respective specifications.

## **2. The ST P-5A Contractor's Scope of Works**

- 2.1 Where details of the ST P-5A Contractor's design are required to enable the Civil Works Contractors to implement the interface works, the ST P-5A Contractor shall provide the Civil Works Contractors with the necessary information. The level of information provided shall be of sufficient detail to enable the Civil Works Contractors to construct the interface works required.
- 2.2 The ST P-5A Contractor shall associate in developing the System Interface Management Plan in conjunction with the Civil Works Contractors to cover all aspects of the implementation of the interface works in this Annexure and all other interface works required to complete all works in the ST P-5A contract, including, but not limited to, those listed in clause 4 herein below.
- 2.3 The ST P-5A Contractor shall liaise with Civil Works Contractors during the development of the Interface Management Plan for any requirements of the Works.

## **3. Civil Contractors' Scope of Works**

- 3.1 The Civil Works Contractors shall liaise with the ST P-5A Contractor in the detailed design, installation, testing and acceptance of the civil works provisions provided for the installation of TPWS system by the ST P-5A Contractor.

- 3.2 The Civil Works Contractors shall provide all access and attendance necessary in accordance with the General Specification to enable the ST P-5A Contractor to complete those activities defined under clause 4 of this Appendix in a timely manner. Such access and attendance shall include, but not be limited to, the safety supervision if necessary, safe access and egress to all parts of the Works required to complete the survey and marking out Works. The Civil Works Contractors shall also provide competent personnel to witness and assist with the marking out activities and enable ST P-5A to use the main survey control data efficiently.
- 3.3 The Engineer shall make available results of geotechnical survey done by Civil Works Contractors to STP-5A Contractor, if required, for ensuring suitable & safe foundations for Location Boxes.
- 3.4 Where Civil Works Contractor's non-conformances are identified which shall impact on the ST P-5A Contractor's interface, the Civil Works Contractors shall submit the proposed remedial measures to the Engineer for review.

#### **4. Functional Interface**

- 4.1 The ST P-5A Contractor shall work with CT P-1, CT P-2, CT P-3, CT P-11, CT P-12 and CT P-13 Contractors to obtain a continuous Track layout plan starting at the Rewari end of CT P-1 through to the Mumbai end of CT P-11. All Contractors shall co-operate to obtain plan. This plan shall be used for common project working chainages for all contractors. CT P-1, CT P-2, CT P-3, CT P-3A, EM P-4, ST P-5, PE P-6, RS P-7, CT P-11, CT P-12, CT P-13, CT P-15A, CT P-15B, EM P-16 and ST P-17 Contractors shall liaise with ST P-5A contractor for suitable access dates for taking up & completing TPWS construction works to enable continuous progress of works without any hold up.

- 4.2 Other contractors (Civil and Track) are required to standardize the layer naming in the Civil Works Drawings and numbering convention so as to allot layer numbers in the CAD layering as referred to in ER GS Appendix 8, para 3.7 to ST P-5A and other remaining contractors such as ST P-5, ST P-17, EM P-4, EM P-16 etc. so as to make the layout plans pertaining to their discipline of work on the allotted layer. The ST P-5A Contractor shall use the same CAD File on his allotted layer to develop his Construction Drawings.
- 4.3 ST-P-5A Contractor shall liaise with Civil works Contractors for provision of space for digging trench (if required) along both UP and DN lines in block section for laying TPWS cables.
- 4.4 ST-P-5A Contractor shall liaise with Civil works Contractors for alignment of storm drains along the track to ensure that the alignment of Cable trenches and storm drains do not obstruct each other.
- 4.5 ST-P-5A Contractor shall liaise with the Civil Works Contractors for fixing Balise on sleepers.
- 4.6 Civil Works Contractors shall provide and lay 100mm dia Double Wall Corrugated HDPE pipes under the track for the following and at the locations as decided by ST P-5/ST P 5A contractors:
- (i) Track crossing of cables at 50 locations per station considering Home to Home signal as station area and at 4 locations per Km in Block Sections;
  - (ii) Platform crossing at from Relay Room to track side at 2 locations per station;
  - (iii) Road crossing at 2 locations per Level Crossing.

For the above, ST P-5A Contractor shall give his requirements to ST P-5/ST P-17 Contractor for Compilation and conveyance to Civil Contractors.



4.7 The buildings for Signal and Telecom equipment rooms, PSS(S&T) rooms and maintenance depots shall be constructed by the Civil Works Contractors. ST P-5 Contractor shall provide necessary details to finalise the layout of these structures. Floor loading details shall also be furnished by ST P-5 Contractor to the Civil Works Contractors before the construction of respective buildings is taken up by them.

For the above, ST P-5A Contractor shall give his requirements to ST P-5/ST P-17 Contractor for Compilation and conveyance to Civil Contractors.

4.8 ST P-5A contractor shall give his requirement for fixing cable channels on steel bridges to concerned Civil Works Contractors. Cable channels and its fixing arrangements shall be supplied and installed by ST P-5A contractor.

4.9 Civil Works Contractors shall furnish design of track formation, cess, track separation on main line and yards for erection of, location boxes etc. by ST P-5A contractor.

4.10 Civil Works Contractors shall prepare Coordinated Construction Programme in association with ST P-5, ST P-5A & ST P-17 Contractors and shall provide the section wise dates to them as to when the access to different sections shall be made available for carrying out their activities.

4.11 ST P-5A Contractor shall arrange provision of TPWS equipment as per access dates at different stations & sections as provided by Civil Works Contractors.

4.12 Civil Works Contractors shall liaise with ST P-5A Contractor & the Engineer / Employer for identifying the land required for Temporary Office/ store, within the ROW and shall provide the access dates for the same.

4.13 Civil Works Contractors shall liaise with ST P-5A Contractor to decide height of false ceiling and location of Air Conditioning system in Electronic Equipment Rooms and

Ventilation System in Power Supply/Battery rooms so that there is no hindrance to fixing of equipment racks.

- 4.14 Civil Works Contractors shall provide additional earth work above slope section on the embankment or by the side of the track in coordination with ST P-5A Contractor for provision of Location Boxes.
- 4.15 ST P-5A Contractor shall give details of TPWS equipment dead load on bridges (cables, etc.) to concerned Civil Works Contractors.

\* \* \* End of Appendix 7-3 \* \* \*

**ANNEXURE 7-4: NOT USED**

\* \* \* End of Appendix 7-4 \* \* \*

**ANNEXURE 7-5: NOT USED**

\* \* \* End of Appendix 7-5 \* \* \*

## **ANNEXURE 7-6: INTERFACE ISSUES BETWEEN ST P-5, ST P-17 AND ST P-5A**

### **1. Definition and Scope**

- 1.1 This Annexure describes the interface requirements between ST P-5A Contractor and Other Signal & Telecom contractors ST P-5/ST P-17 carrying out Signalling works from Rewari to JNPT.
- 1.2 All interface shall be through the Employer.
- 1.3 Throughout this Annexure, 'the Contractor' shall mean the ST P-5A Contractor, whereas 'the Contract' shall mean Contract ST P-5A.
- 1.4 The interface issues between the Contractor and ST P-5/ST P-17 Contractors shall have to be identified. Such issues arise primarily at the following interfaces: -
- (i) Cable laying;
  - (ii) TPWS equipment provision;
  - (iii) Power Supply for TPWS.
- 1.5 The scope shall comprise of but not limited to the following:
- (i) Laying of cables:
    - a. Cables shall ordinarily be laid in common trench dug by P-5/P-17 Contractors in Block Section and common Duct provided by P-5/P-17 Contractors at stations;
    - b. Each of P-5/P-17 and P-5A Contractors shall coordinate so that they lay cables simultaneously.
    - c. In case P-5/P-17 Contractors consider it necessary to lay cables and close the trench before P-5A Contractor lays his cables, P-5/P-17 Contractors shall submit proposal to the Engineer with full details for his consent.

- d. If P-5A Contractor has to lay cables in a closed trench, he shall open the trench manually with utmost care so that no damage is caused to cables already laid.
  - e. If opening of existing trench leads to any damage to cables already laid by the other Contractor, the Contractor opening the trench shall be fully responsible for the same and shall compensate the other Contractor which shall be mutually settled between the two Contractors. In case of any dispute, the matter shall be referred to the Engineer whose decision shall be final and binding on both the Contractors.
  - f. P-5A Contractor shall normally use CTR provided by P-5/P-17 Contractors.
  - g. If at any place, CTR/Trench/Duct provided by P-5/P-17 Contractors either does not exist or cannot accommodate P-5A cables, P-5A Contractor shall provide his own CTR/Trench/Duct. Details of the same shall be submitted to the Engineer for his consent.
  - h. P-5A Contractor shall lay balise cable on the side of Telecom cables separated by bricks in trench/ duct. If in any stretch of trench/ duct provided by P-5/ P-17 Contractors, no telecom cable is laid, then P-5/ P-17 Contractors shall provide brick separation with balise cable.
- (ii) P-5/P-17 Contractors shall provide required space to P-5A Contractor for fixing TPWS equipment in SER/ Auto Location Huts.
- (iii) Power Supply:
- a. Each of P-5/P-17 and P-5A Contractors shall coordinate so that power supply load requirement (in terms of watts) for TPWS in SER/ Auto

Location Huts/ Location Boxes is incorporated in PSS being provided by P-5/P-17 Contractors;

b. P-5A Contractor shall use as it is, convert to required voltage or extend available power supply as required from panel and/or Location Boxes as indicated by P-5/P-17 Contractors. This shall be protected by a separate fuse to be provided in the panel by P-5/P-17 Contractors.

(iv) P-5/P-17 Contractors shall provide potential free relay contacts for input to LEUs even by providing repeater relays, if required. While LEUs shall normally be kept inside the Auto Location Huts, if any LEU has to be installed in a Location Box due to design considerations, then P-5 Contractor shall provide the said repeater relay in the Location Box containing the LEU.

(v) TPWS equipment failure inputs shall be provided by P-5A Contractor in agreed format to P-5/P-17 Contractors for its integration with failure alarms and reports in TMS.

(vi) Earthing of TPWS indoor as well as track side equipment shall be suitably coordinated and provided by P-5A Contractor.

(vii) Each of the Contractors shall coordinate for successful conduct of Integrated testing.

(viii) In exceptional cases splicing required for making available fibres for monitoring of TPWS equipment along the track side shall be provided by ST P-5 Contractor.

1.6 ST P-5/ST P-17 shall be the lead contractors in their respective sections.

\* \* \* End of Annexure 7-6 \* \* \*

## **ANNEXURE 8: SPECIFICATIONS OF PRE-FABRICATED AUTO LOCATION HUTS**

### **1 General:**

- 1.1 These shall be provided by ST P-5/ST P-17 Contractors and are included in this document only for information of ST P-5A Contractor.
- 1.2 Pre-fabricated structures shall be of steel construction.
- 1.3 All pre-fabricated structures shall be resistant against shock and vibration from passing trains.
- 1.4 The construction must be water proof against rainfall.

### **2 Wall Construction.**

- 2.1 External facing shall be of galvanized sectional sheet-metal.
- 2.2 Adequate thermal insulation shall be provided by using Polyurethane Foam (PUF) of adequate thickness.
- 2.4 NOT USED.
- 2.5 Doors of adequate size to permit entry of largest equipment cabinet. Door locks to be provided. Opening and closing of doors shall be monitored through TMS.

### **3 Roof Construction**

- 3.1 The roof shall be protected from sun heat with adequate thermal insulation.
- 3.2 Height shall be sufficient for installation of equipment to ensure running of cable/wiring trays and provision of tube lights.
- 3.3 NOT USED.



- 3.4 Adequate and suitable drainage system for roof and the whole area outside shall be provided.
- 3.5 Roof structure may be formed by pitch roof panels and trusses covered with OSB radiant barrier roof panels/sandwich panels of adequate size or any other equivalent.
- 3.6 The surface obtained after the implementation/application of OSB covering shall then be applied with requisite number of layer waterproofing membrane.
- 3.7 Subsequent process shall be application of shingle waterproofing membrane of suitable colour and texture as roof covering material to make it waterproof for climate conditions in the project section.

#### 4 **Floor Construction:**

- 4.1 Sub-floor shall be of galvanized sheet metal.
- 4.2 It shall be made waterproof with bonded hardboard plates.
- 4.3 Good thermal insulation shall be achieved using mineral wool/rock wool/rubber/fibre glass or any other equivalent suitable material of adequate thickness.
- 4.4 Floor openings for cables as needed shall be provided.

#### 5 **Floor Covering.**

- 5.1 Elevated double floor may be provided only if rack to rack/rack to equipment cabinets overhead cabling;/wiring is seen to be problematic.
- 5.2 Carrying capacity 20 kN/m<sup>2</sup>, at a point load capacity of 3,000 N or adequate to cater for maximum load requirement.
- 5.3 Surface shall consist of PVC covering/tiles.

#### 6 **Corrosion protection:**

This shall be achieved using following measures:

- 6.1 Frame construction: Shot-blasted with steel and primed.
- 6.2 Facing of sectional sheet-metal, galvanized.
- 6.3 Sectional sheet-metal for roof, galvanized and preferably plastic-laminated or any other equivalent.
- 6.4 Flat-type sheet-metal for dead floor, galvanized.
- 7.0 **Electrical Installation:**
- 7.1 Space for Auto change over switch and termination of AT supply from UP & DN Catenary to be provided. Auto change over switch with termination from UP & DN catenary shall be carried out by P-4/P-16 contractor.
- 7.2 Internal electrical wiring & fixtures for light, power socket etc. shall be provided by the ST P-5/ST P-17 contractors.
- 8 **Foundation:**
- 8.1 Provision of concrete foundations including earth work, if necessary, to be done.
- 8.3 Channels and openings required for cables leading to the individual structures shall be designed in a way that replacement of cables is possible. Cable entry shall be Rodent & pilferage proof.
- 9 **Lightning Protection.**
- 9.1 The outdoor lightning protection shall cover persons as well as all equipment and facilities to be protected.
- 9.2 The lightning current shall be captured and discharged to the earthing system.
- 9.3 Air termination network consisting of lightning conductors and lightning rods shall be installed. Traction earth may be used if available nearby. Otherwise, a ring-shaped

earth shall be used for discharging the lightning current. The tracks must not be used as part of the lightning protection system.

## **10 Air Conditioning**

- 10.1 Each Porta Hut shall have two rooms one for Electronic Equipment and the other for Power Supply/Battery System. Electronic Equipment (including for electronic equipment provided by ST P5-A Contractor) shall be provided with Panel Air-conditioning with air-conditioning equipment in (1+1) hot standby configuration to regulate temperature of the equipment within 24+/-2 degree C. Further, these Electronic Equipment Rooms shall be provided with suitable means to maintain air circulation with (1+1) standby air-circulation system.
- 10.2 The Power Supply/Battery Room of the Porta Hut shall be provided with ventilation and suitable means to regulate temperature and maintain air-circulation with (1+1) standby air-circulation system.
- 10.3 The Panel air-conditioning and air-circulation system in Porta Huts shall be provided by the ST P-5/ST P-17 Contractors. A suitable plan to this effect shall be submitted to the Engineer for his consent as part of the Preliminary Design.
- 11 The entire design shall be pilferage proof.

\* \* \* End of Annexure 8 \* \* \*

**ANNEXURE 9: GUIDELINES ON SIGNALLING CABLE LAYING**

Government of India - Ministry  
*Research Designs &*  
LUCKNOW – 226011



सत्यमेव जयते

of Railways  
*Standards Organisation*

**GUIDELINES**

**ON**

**SIGNALLING CABLE LAYING**

Number of Pages - 44

Issued by

SIGNAL DIRECTORATE

RESEARCH, DESIGNS & STANDARDS ORGANISATION

MINISTRY OF RAILWAYS

MANAK NAGAR

LUCKNOW – 226 011

October 2011

## INDEX

<b>Para</b>	<b>Content</b>	<b>Page No.</b>
1.	Background	3
2.	General	3
3.	Planning for cables	3
4.	Planning for cable route	5
5.	Laying of cable above ground	6
6.	Excavation and backfilling of the trenches	6
7.	Cable laying in underground	7
8.	Track crossing	10
9.	Road crossing	10
10.	Cable laying on bridges/culverts	11
11.	Laying near to sleeper	11
12.	Jumper cables for track circuits	12
13.	Cable markers	12
14.	Storing & transportation of cable	12
15.	Paying out the cable	13
16.	Laying the monsoon season	13
17.	Entry of cable at cabin, relay room, location boxes etc.	13
18.	Cable termination	14
19.	Testing of cable	14
20.	Instructions for insulation resistance testing of signalling cable	15
21.	Supervision of cable laying	16
22.	Special requirements in 25 kV AC electrified area	16
23.	Drawings for cable laying	17
24.	Annexure-1	18
25.	Annexure-2	21
26.	Annexure-3	22
27.	Annexure-4	23
28.	Annexure-5	24
29.	Annexure-6	25
30.	Annexure-7	26
31.	Annexure-8	27
32.	Annexure-9	28
33.	Annexure-10	29
34.	Annexure-11	30
35.	Annexure-12	31
36.	Annexure-13	32
37.	Annexure-14	33
38.	Annexure-15	34
39.	Annexure-16	35
40.	Annexure-17	36
41.	Annexure-18	37

42.	Annexure-19	38
43.	Annexure-20	39
44.	Annexure-21	40
45.	Annexure-22	41
46.	Annexure-23	42
47.	Annexure-24	43
48.	Annexure-25	44

## 1. Background

- 1.1 The Signal Engineering Manual (SEM) covers broadly various instructions on laying of signalling cables. Railway Board have also issued guidelines on the subject from time to time. This issue of cable laying practices has also been discussed in many forums like CSTE's Conference, MSG's etc.
- 1.2 On account of multiple faults in the cable and inadequate protection arrangement against short/open circuit faults, failures of point and other signalling gears have taken place on various Zonal Railways. In some of the cases, Railways signalling cables are invariably damaged by JCB & other track machine operated by Engineering Department, which resulted in serious dislocation to train services inviting criticism from different quarters. In view of this, board has asked RDSO to prepare detailed instruction for laying of signaling cable.
- 1.3 Following documents are also considered while preparing this document:-
- 1.3.1 Railway Board's Joint Procedure Order No. 1/SG/2004 issued under D.O. letter No. 2004/Sig/G/7 dated 17.12.2004.
- 1.3.2 Railway Board's letter No. 2004/Sig/AWR/1 dt. 20.07.2007 enclosing Joint Committee Report No. SS-117/2007 and RDSO's comments on the report.
- 1.3.3 Cable Laying Practices followed by various Zonal Railways i.e. CR, WR, SR & RE etc.
- 1.3.4 Railway Signalling Installation and Quality Handbook.
- 1.4 These guidelines on signalling cable laying containing consolidated instructions on the subject are being issued for uniform adoption by Railways.

## 2. General

2.1 Railway signalling circuits shall normally be carried on cables. For new works, signalling circuits shall only be carried on cables. In 25 KV AC electrified areas overhead lines shall not be used.

## 3. Planning for cables

3.1 Cables used for carrying signalling, circuits shall conform to relevant approved specification. The conductors used shall be of annealed copper and of approved size. For this purpose, specification No. IRS:S 63 may be referred.

3.2 3.2Power cable used for carrying power supply for signalling circuits shall conform to relevant approved specification. The size of conductor shall be so selected as to suit the electrical load. For this purpose, specification No. IRS:S 63 may be referred.

3.3 The Core-wise usage of signalling cable is as given below:-

Core & Cross section	RDSO Specification	Usage
6 Core x 1.5 mm <sup>2</sup>	IRS S 63	Tail Cable
12 Core x 1.5 Sq. mm <sup>2</sup>	IRS S 63	Tail Cable/LC Gate/Main Cable
19 Core x 1.5 Sq. mm <sup>2</sup>	IRS S 63	Main Cable
24 Core x 1.5 Sq. mm <sup>2</sup>	IRS S 63	Main Cable
30 Core x 1.5 Sq. mm <sup>2</sup>	IRS S 63	Main Cable
2 Core x 2.5 Sq. mm <sup>2</sup>	IRS S 63	Track circuit lead connections
12 Core x 2.5 Sq. mm <sup>2</sup>	IRS S 63	Main/Tail Cable
2 Core x 16 Sq. mm <sup>2</sup>	IRS S 63 & IS 1554	Power cable
2 Core x 25 Sq. mm <sup>2</sup>	IRS S 63 & IS 1554	Power cable
2 Core x 35 Sq. mm <sup>2</sup>	IRS S 63 & IS 1554	Power cable
2 Core x 50 Sq. mm <sup>2</sup>	IRS S 63 & IS 1554	Power cable
4/6 Quad Cable (0.9 mm)	IRS TC:30	Axle Counter

3.4 A cable core distribution plan is required to be prepared for each installation. Cables for power distribution shall be indicated for each signaling gear. A sketch No. SDO/CABLE LAYING/001 showing typical main cable distribution plan including

power cable for field gears for a typical double line (4 lines) PI station is enclosed **(Annexure-4)**.

3.5 The distribution of various power supplies for operating signalling gear in yard shall be covered in cable distribution plan issued by CSTE of Zonal Railways. However, following guidelines may be followed:-

3.5.1 In general following power supplies and required to distribute on each side of the station:-

- (i) 110V AC for track feed battery charger etc.
- (ii) 24/60 DC for external for TPR, point detection etc.
- (iii) 24 DC external for electronic equipment like Axle Counter, BPAC etc.

3.5.2 The above power supplies as per the requirement of the station may be extended on each side of station and terminated at all main location boxes/huts.

3.5.3 All the power supplies at wayside stations as well as major yards may be laid with redundancy i.e. 2 power cables for each circuit to avoid major signalling breakdown affecting punctuality of train services during any damage/cable becoming faulty. A changeover switch may be provided at either end of the station for extending the alternate power supply in case of failure.

3.5.4 In RE area, for automatic signalling, IBH, mid-section, level crossing gates and at station where location boxes/huts are more than 2 km power supply may be taken from auxiliary transformer.

3.5.5 In Non-RE area, for automatic signalling, IBH and mid-section level crossing gates, power supply may be extended from stations on either side. The arrangement shall be such that the power supply from one of station can be extended while at same time power supply from other station shall remain isolated.

3.6 While planning for cabling on a route, the number of conductors required, for the circuits shall be first determined. Recommended core sizes shall be used.

3.7 Adequate spare conductors to a minimum of 20% of the total conductors used shall be provided for in each main cable up to the farthest point zone, beyond this there shall be a minimum of 10% spare conductors of the total conductors used. The spare conductors shall be provided on the outermost layer. 2 numbers of 12 Core dedicated spare cable from home signal to home signal may be laid and terminated



in all locations for instant transfer of these dedicated conductors in case of cable failure and cable testing.

- 3.8 Where a number of cables have been laid along a route, the circuits shall be so distributed that cables can be disconnected for maintenance purpose with the least possible dislocation to traffic. Line wise and, if necessary; function wise cable shall be provided. Auxiliary signals shall be taken in different cables.
- 3.9 Separate cables of suitable size shall be laid for point operation.
- 3.10 Numbering of cable to be done in ascending order from right hand side of the cable core distribution plan.
- 3.11 Number of location boxes shall be kept at minimum. Where too many locations boxes (say more than 10) are coming in a close proximity generally between starter & home signal, it is proposed to use location huts instead of location boxes for security, proper protection and ease of maintenance. Prefabricated huts (approximate size 10 feet x 10 feet) may be used, the drawing/design of which shall be issued by RDSO separately.

#### **4. Planning for cable route**

- 4.1 After deciding the size and the number of conductors in the different types of cables to be used on a route, a foot survey along the track shall be done to determine the best route for the cable.
- 4.2 The route shall be shown clearly on a cable route plan showing the actual alignment of track, giving offsets from permanent way or permanent structures. The diagram shall indicate the various road and track crossings, crossing with power cables, water and sewage mains and other points of importance. It is preferable to chart the route on a route plan on which the existing routes of power cables, etc. are shown. Changes, if any, shall be incorporated in the chart/plan.
- 4.3 While planning cable route plan, any future yard modification/doubling etc. shall also be kept in view.
- 4.4 Cable route plan shall also be approved by Engineering and Electrical Department. Cable route plan shall also be approved by Branch Officer of Signal & Telecom (Open Line) wherever it is prepared by organization other than open line.

- 4.5 As far as possible low lying areas, platform copings, drainages, hutments, rocky terrains, points and crossings, shall be avoided.
- 4.6 Wherever JCB/Mechanized trenching or any kind of digging cases near existing cables is resorted, instructions contained in Railway Board's JPO No. 1/SG/2004 issued under D.O. letter No. 2004/Sig/G/7 dated 17.12.2004 (**Annexure-1**) shall be followed.

## **5. Laying of cable above ground**

- 5.1 Signalling cables for outdoor circuits shall not normally be laid above ground. In exceptional cases where it becomes unavoidable, the following precautions shall be taken:-
- i) The cable shall be suspended in wooden cleats, from cable hangers or in any other approved manner so that no mechanical damage occurs to the cable even under exposed condition.
  - ii) The cable supports shall be so spaced as to avoid sag.
  - iii) In station yards, cable shall be laid in ducts suitably protected.
- 5.2 Indoor signalling cable shall normally be laid on ladders, channels or in any other approved manner. The cables shall be neatly tied/laced.
- 5.3 In AC electrified areas cables shall be laid underground only. For laying cables in RE area instructions laid down in Chapter XXII of SEM shall also be followed. Extract of this chapter are available in para 22 of these guidelines.

## **6. Excavation and backfilling of the trenches**

- 6.1 Manual trenching is recommended for laying of signalling cables in the station yards from Home to Home signal and mechanized trenching is recommended from Home to distant signal and beyond into block/automatic section.
- 6.2 Under road/platforms/railway tracks/difficult terrain etc., trench less horizontal directional drilling (HDD) method may be adopted under the supervision of competent staff for laying of GI/DWC-HDPE pipe. Both ends of GI/DWC-HDPE pipes shall be closed properly using accessories and the pits shall be properly backfilled. There shall be no damage to the road/platform/tracks or any such structures etc. enrooted during or after the HDD operations.

- 6.3 Excavation of cable trench shall be made in all kinds of soils including clearing roots of trees, rocks etc. Trenches shall be straight as far as possible and steep angles shall be avoided.
- 6.4 The bottom of the trench shall be levelled and got rid of any sharp materials. No sharp object like stone chips, iron pieces etc. shall ever come in contact with laid cables irrespective of the method of laying the same.
- 6.5 After cable has been laid and until the whole of the cables to be laid in the trench have been covered with their protective covers, no sharp metal tool such as spades, crowbar or fencing pins shall be used in the trench or placed in such a position that they may fall into the trench.
- 6.6 When cables are laid in trunking, care shall be taken to see that no ballast or stones have been dropped inside the trunking. The trunking shall be cleared of all ballast and stones before the cover is secured. When the ends of covers are joined together with cement plaster, a piece of paper or wood shall be placed under the joint to prevent the cement plaster from falling on the cable.
- 6.7 It is desirable that the excavation of the trenches is not done in long lengths and does not remain uncovered for long period. It is preferable that cables are laid and refilling done on the same day.
- 6.8 Before commencement of the laying, inspection of the trench and inspection of protection works shall be carried out so as to ensure their conformity with the specification. A sketch No. SDO/CABLE LAYING/022 rule made of pipe for measuring depth is enclosed (**Annexure-25**).
- 6.9 Backfilling of the trenches shall be done properly. The earth excavated shall be put back on the trench, rammed and consolidated.
- 6.10 During excavation, the earth of the trenches shall not be thrown on the ballast. The earth shall be thrown by the side of the trenches away from the track.

## **7. Cable laying in underground**

### **7.1 General**

- 7.1.1 Cables may be laid underground, either in the trench, in ducts, in cement troughs, in pipes or in any other approved manner.

- 7.1.2 Cables shall be laid generally as per instructions given in these guidelines. However, special precautions to be taken in the station yards etc. where a number of other utilities may be existing, may be detailed in a joint circular issued by the Civil Engineering, Signalling and Electrical Department (where applicable) of the Railway. Railways may provide any additional protection as necessary at a particular location due to prevailing law and order problem.
- 7.1.3 Cable is generally laid parallel to the track beyond Home signal with minimum deviations and on one side of the yard.
- 7.1.4 As far as possible, cable shall be crossed only at two locations, i.e. one crossing on each side of the yard.
- 7.1.5 The cable laid parallel to the track shall be buried at a depth of minimum 1.0 metre (top most cable) from ground level. A sketch No. SDO/CABLE LAYING/003 showing cable trench is enclosed (**Annexure-6**). While those laid across the track must be minimum 1.0 metre below the rail flanges. However, in case of rocky soil, the depth may be reduced suitably. When it concerns the laying of tail cables which serve the track apparatus etc. the depth shall not be less than 0.50 metres. In theft prone areas the cables may be laid at a depth of 1.2 metres with anchoring at every 10 metres.
- 7.1.6 The width of manually made cable trenches shall commensurate with number of cables. The minimum width shall be kept as 0.3 meters. The bottom of the cable trench shall be levelled and got rid of any sharp materials. In the soft ground, the cable shall be laid at the bottom of the trench previously levelled. In the rocky ground, the cable shall be laid on a layer of sand or sifted earth of 0.05 metre thickness previously deposited at the bottom of the trench. In both the above cases, the cable shall be covered with a layer of sand or sifted earth of 0.10 metre thickness and thereafter a protective cover of trough or a layer of bricks shall be placed.
- 7.1.7 Normally, not more than 12 cable are to be laid in one trench as it shall be difficult to attend failure at a later date. At a moderate size station with electrical signaling installation, generally the numbers of cable are more up to home, it is recommended that cables are laid in RCC duct up to home signal on both side of the station and may be extended up to distant, if required. This will also help later for laying of additional cable later without carrying out trenching.

7.1.8 While laying the cables in accordance with the above instructions, the following instructions shall be adhered to for the safety of the track:-

- i) Outside the station limits, the cables shall generally be laid at not less than 5.5 metre from the centre of the nearest track.
- ii) Within the station limits, the trenches shall preferably be dug at a distance of not less than 3 metre from the centre of the track, width of the trench being outside the 3 metre distance.
- iii) At each end of the main cable an extra loop length of 6 to 8 metre shall be kept.

7.1.9 Before starting cabling work location boxes shall first be erected so that cable after laying is directly taken inside location box and its multiple handling/damage by re-digging and taking inside location box/Relay Room is eliminated.

7.1.10 A sketch No. SDO/CABLE LAYING/002 showing position of trenches for cable laying is enclosed (**Annexure-5**).

## 7.2 Laying of different type of cable in same trench

7.2.1 Where several cables of different categories have to be laid in the same trench, they shall be placed as far as possible in the following order starting from the main track side, so that in the event of failures, the maintenance staff may easily recognise the damaged cables:-

- i) Telecommunication cable
- ii) Signalling cable
- iii) Power cable

7.2.2 A distance of approximately 10 cm must be maintained between telecommunication cable and signalling cables. The signalling cables must be separated from power cables by a row of bricks between them.

7.2.3 A sketch No. SDO/CABLE LAYING/004 showing laying of signalling cable & Telecom/Power cable in same trench is enclosed (**Annexure-7**).

## 7.3 Cable laying in ducts

- 7.3.1 RCC, masonry or any other approved type of ducts may be used for laying the cable. The ducts shall have suitable covers and shall rest on walls of duct.
- 7.3.2 The ducts shall be of such design as to prevent water collecting in the duct.
- 7.3.3 After placing the trunking in the trench the ducts have to be aligned using 8 mm rod. For this purpose, a hole is left in the trunking for insertion of rods. Wherever there is a diversion proper care shall be taken to cover the cables, either by smoothly forming a curve with duct or a masonry structure can be constructed to protect the cables. After laying of cables the ducts shall be covered with RCC slab and shall be continuously plastered at the end with trunking.
- 7.3.4 When cables are laid in rocky area, it is desirable to protect them with split RCC ducts of suitable design.
- 7.3.5 Where it is necessary to take the cable between the tracks, it shall be carried in trunking kept sufficiently below the ballast level.
- 7.3.6 Cables for longer distances shall be laid on bottom layer. Duct shall be filled up with sand after cable is laid to avoid entry of rodents.
- 7.3.7 From Home to Home Signal, where number of signalling cables required are more, subject to availability of space adjacent to tracks, RCC ducts with removable top cover with larger width up to 500 mm are recommended to be used.
- 7.3.8 Beyond Home Signal and up to distant signal including block section/ automatic section RCC ducts with a width up to 300 mm are recommended to be used.
- 7.3.9 Partition of RCC duct for accommodating different types of signalling/telecom cables/ power cables may be provided, wherever required. This can be achieved by earmarking about 80% of inner space for multi core signalling/ telecom cables and the remaining 20% of space for carrying power cable more than 110V in a separate of chamber.
- 7.3.10 In RCC ducts it is recommended to have height of maximum 300 mm (outside dimension inclusive of removable top cover). Length of the duct shall be between 700 mm to 1000 mm (outside dimension). This is mainly required for easy transport of ducts from factory premises to the work sites.
- 7.3.11 Depth of 600 mm to 1000 mm is recommended according to requirement of Zonal Railways depending on site condition and Law & Order situation.

7.3.12 A sketch No. SDO/CABLE LAYING/005, 006 & 007 showing RCC duct is enclosed  
**(Annexure-8, Annexure-9 & Annexure-10).**

#### **7.4 Laying cable in solid & rocky soil**

- 7.4.1 In case of rocky soil the depth may be reduced suitably.
- 7.4.2 Sharp edges on the sides must be smoothed out and bottom of the chase shall be leveled. In the rocky ground the cable shall be laid normally on layer of sifted earth of 0.05 metres thickness previously deposited at the bottom of the trench. Cable shall be covered with the layer of sand or sifted earth of 0.1 metre thickness.
- 7.4.3 In case sharp edge of rocky ground cannot be protected with sifted earth, concrete/GI/CI/PVC/DWC-HDPE pipe shall be used if number of cables are small. If number of cables are large, RCC duct shall be used. In isolated cases, it can be given smooth surface by using either masonry bricks or cement concrete.
- 7.4.4 A row of bricks shall then be placed lengthwise on the top and jointed with cement mortar and a layer of concrete with cement plaster shall be provided on the top of the same.
- 7.4.5 A sketch No. SDO/CABLE LAYING/008 showing laying of cables in rocky area is enclosed **(Annexure-11).**

#### **7.5 Laying in special soil condition**

- 7.5.1 Cable shall not be run through abnormally high acidic or alkaline soil or through sewages. If this is unavoidable special measures shall be taken against corrosion. Cable may be laid in the concrete/GI/CI/PVC/DWC-HDPE pipes properly jointed to prevent ingress of moisture.

#### **7.6 Cable laying in residential area**

- 7.6.1 When laying the cable in residential area, the cable shall be specially protected on both sides up to a distance of about 300 metres beyond the building line. In such cases, the cable shall be protected by means of concreting of 50 mm as proposed for rocky soil. This is better than using bricks as in a residential area bricks are usually found while digging and its special significance of cable protection may be overlooked.

## 7.7 Cable laying in large yard and suburban area

7.7.1 Main signalling cable in large yards including suburban section shall be laid in RCC ducts/DWC-HDPE pipes.

7.7.2 Tail cables shall be laid through DWC-HDPE pipes of suitable sizes and buried in trenches at a depth of not less than 1000 mm from ground level.

## 8. Track crossing

8.1 As far as possible, cable shall be crossed only at two locations, i.e. one crossing on each side of the yard.

8.2 When a cable has to cross the track, it shall be ensured that-

- i) The cable crosses the track at right angles;
- ii) The cable does not cross the track under points and crossings and
- iii) The cable is laid in concrete/GI/CI/PVC/DWC-HDPE pipes or suitable ducts or in any other approved manner while crossing the track.
- iv) Cable laid across the track must be 1.0 metre (minimum) below the rail flanges.
- v) No digging shall be done below the sleepers. Digging work while crossing a track shall be done between sleepers in the presence of a Railways representative.

8.3 A sketch No. SDO/CABLE LAYING/009 showing track crossing is enclosed **(Annexure-12)**.

## 9. Road Crossing

9.1 The cable is laid in concrete/GI/CI/PVC/DWC-HDPE pipes, suitable ducts or in any other approved manner while crossing the road at the depth of 1 metre from the ground level. It shall extend 1 metre (minimum) on each side of the road keeping in view the future increase of width of the road.



- 9.2 When crossing roads, it is necessary to lay the cables in such a manner as to avoid the necessity of bending the cable sharply and minimise the excavation of road surface as far as possible.
- 9.3 The crossing of main roads often involves difficulties, especially if traffic is heavy. Precautions to avoid accidents to workmen, pedestrians and vehicles shall be taken. On minor roads, which can be temporarily closed to traffic it is possible to open up across the entire width of the road, pipes shall be installed quickly in the cutting, which is then filled in there by reducing to a minimum the time for which the road is closed.
- 9.4 Some roads, which are broad, may be opened for half their width allowing the other half for use of traffic, pipes are laid, trench filled in the first half and the other half opened up after the first half is opened half is linked with those laid in the first half.
- 9.5 Whenever a cable is laid across an important road, particularly one with a special surface, it is good investment to provide for future expansion. Either the following methods may be adopted:-
- (a) The size of the pipe shall be so chosen that provision for laying few cable is future is kept in view. Pipes having diameters ranging from 100 to 200 mm are suggested, or
  - (b) A spare pipe may be laid, through which a cable can be drawn when required. It will be advantageous to leave a lead wire of G.I. wire in the pipe for drawing the cable in future.
- 9.6 A separate pipe of suitable dia shall be used for telecommunication cable.
- 9.7 A sketch No. SDO/CABLE LAYING/010 showing road crossing is enclosed(Annexure-13).

## 10. Cable laying on bridges/culverts

- 10.1 Wherever practical, the cable may be taken underground across the drain bed at a suitable depth for crossing small culverts with low flood level. A sketch No. SDO/CABLE LAYING/011 showing cable laying on culverts with low flood level is enclosed (**Annexure-14**).

- 10.2 Where cable may not be taken underground across the drain bed, cable shall be taken on the culvert through GI/DWC-HDPE pipe of suitable sizes. A sketch No. SDO/CABLE LAYING/012 showing cable laying on culverts with high flood level is enclosed (**Annexure-15**).
- 10.3 When cables have to cross a metallic bridge, they shall be placed inside a metallic trough which may be filled, as an anti-theft measure, with sealing compound. The cable shall be supported across the bridge in a manner which would involve minimum vibrations to the cable and which will facilitate maintenance work. Adequate cable length to the extent of 2 to 3 meters shall be made available at the approaches of bridge. A sketch No. SDO/CABLE LAYING/013 & 014 showing cable laying on metallic bridges is enclosed (**Annexure-16 & Annexure-17**).
- 10.4 In case of arch bridges, cable shall be taken through GI/DWC-HDPE pipes on top of the arch adjoining the parapet wall. The pipe shall be covered with ballast. A sketch No. SDO/CABLE LAYING/015 & 016 showing cable laying on arch bridges is enclosed (**Annexure-18 & Annexure-19**).
- 10.5 Concreting of 50 mm shall be done throughout from entry/exit end of cable up to diversion point including slope on either side. The entry and exit ends of the cable from the pipe to the diversion point of the cable shall be concreted for 1 metre (minimum).
- 10.6 As the laying involves movement of a large number of staff over the bridge the line shall be blocked and flagman posted on other side. On a double line only the line near which the cable is being laid shall be blocked but care shall be taken to see that staff are aware of this and measures taken to prevent staff from straying on to the unblocked line.
- 10.7 Damage to cable is likely to occur if care is not taken in laying cable where the bed changes from solid support such as a foundation, pier of bridge to soft support such as soft soil. The cable must not press against the edge of the solid support. The soft soil near the edge must be tamped and the cable raised slightly.
- 10.8 In order to prevent theft and miscreant activities on approach of cable to bridge/culvert where it is not possible to ensure adequate depth, concrete protection is proposed.

## **11. Laying near to sleeper**

11.1 In places where cables are to be laid within 1 metre from sleeper end, digging beyond 0.50 metre shall be done in the presence of an official from Engineering Department, and the laying of the cable and refilling of trench shall be done with least delay. Laying may be undertaken under block protection as needed.

## **12. Jumper cables for track circuits**

12.1 There are numerous instances of jumper cable cut due to Engineering staff working. Such instances can be minimized if jumper cable is tied with the nearest sleeper. This shall be done on wooden sleepers using iron clamps/hooks. On PSC sleepers jumper cable shall be tied using clamps. A sketch No. SDO/CABLE LAYING/017 showing arrangement of jumper cable is enclosed (**Annexure-20**).

12.2 Where sleeper ends, cable shall be buried underground in the line of sleeper and taken to TLJB. Wherever required, cable may be laid in DWC-HDPE pipe.

12.3 Jumper cable shall be laid at least 0.5 metre below ground level excluding ballast depth.

12.4 Jumper cable shall be laid neatly in squared manner and shall not be kept in loose coils above the ground near TLJB.

12.5 Top surface of TLJB shall not be 1 feet above rail level.

## **13. Cable markers**

13.1 Cable markers wherever provided shall be placed at 30-40 metre interval and at diversion points.

13.2 There are three types of cable markers in use in different Zonal Railways:-

- (a) Cast iron Tablet type cable markers.
- (b) Concrete cable markers.
- (c) Electronic Markers

13.3 Concrete cable markers can be adopted where RCC ducts are used or area is prone to theft. Concrete markers are projected above surface level for at least 300 mm.

13.4 A sketch No. SDO/CABLE LAYING/018, 019 & 020 showing cable marker is enclosed (**Annexure-21, Annexure-22 & Annexure-23**).

#### **14. Storing & transportation of cable**

14.1 Cable drums shall not be stacked on flat side. Suitable stoppers shall be placed for stability.

14.2 Cable drums shall have easy access for lifting and moving.

14.3 When rolling the cable drum either for unloading or transportation, the drum shall always be rotated in the direction of the 'arrow' which is marked on the drum.

14.4 The drums shall not be rolled over objects that could cause damage to the protective battens of the cable.

14.5 When unloading is carried out from the vehicle the drum shall not be dropped on the ground directly to avoid damage due to impact. Fork lifter or ramp shall be used.

14.6 During all stages of storage, it is essential that the ends of the cable are effectively sealed by end cap or in any other approved manner to avoid water entry into the cable.

14.7 It is desirable that cable drums are stored in covered shed to protect against direct exposure to sun.

#### **15. Paying out the cable**

15.1 For paying out cables, the cable drums shall be mounted on cable wheels. It shall be ensured that no kink is formed while paying out the cable. A sketch No. SDO/CABLE LAYING/021 showing method of unrolling cable is enclosed (**Annexure-24**).

15.2 The drum on the wheel shall be brought to one end of the trench and the end of the cable freed and the cable shall be laid along the trench.

15.3 The cable duct shall be brought as close to the cable trench if possible. The cable drum shall clear the ground by 5 to 10 cm.

- 15.4 The wooden battens on the drums shall be carefully removed shortly prior to laying and before the drum is mounted on the jack.
- 15.5 A party of labourers shall move along the trench carrying cable at suitable intervals so that cable is not damaged due to dragging along the ground or bent unduly.
- 15.6 The in-charge of cable laying shall ensure proper synchronization of all labourers for smooth laying.
- 15.7 In cases where the wheels are not available, the drum shall be mounted on an axle at one end of the trench and cable paid out and carried by labourers.
- 15.8 In no case, shall the drum be rolled off on to the road for laying the cable and the cable dragged on the ground for laying purposes.
- 15.9 Whenever mechanized equipment is used, the work shall be carried out by a trained operator under the supervision of SSE/SE/JE (Signal) in-charge of the work.
- 15.10 Where the cable drum is in damaged condition the cable may be placed on a horizontal revolving platform and the cable paid out in the same manner as given in paras above.
- 15.11 Paying out of cable shall be done by rotating the cable drum and not by pulling the cable with excessive force.
- 15.12 Wherever flaking of cable is required, it shall be done by making a succession of loops in the form of Figure '8', these loops being disposed on top of each other to avoid tangling of cable. Figure of '8' flaking shall only be carried out under the direct supervision of an experienced official.

## **16. Laying in monsoon season**

- 16.1 It is not advisable to lay cables in monsoon when the precipitation is heavy. The trenches will be inundated and visual inspection of the bedding of the trench will be rendered difficult. Threading the cable in pipes will also be more difficult.
- 16.2 When however cable laying is necessary during the monsoon season, the cable ends shall be inserted in a pipe sealed at one end and the pipe buried. Termination work shall be started only when there is likelihood of a clear weather for three or four days.

## **17. Entry of cable at cabin, relay room, location boxes etc.**

- 17.1 All cable entry points in cabin, relay room, battery room, SM's room, location boxes, location huts, junction boxes, etc. must be closed with suitable masonry works, sand covered and plastering to prevent entry of rats etc. RCC slab shall be provided on the cable pit of cabin and relay room/station.
- 17.2 Cable shall be protected on both sides up to a distance of 10 metre beyond building line of cabin, relay room, battery room, SM's room. In case of location boxes, location huts, junction boxes etc. cable may be protected for 1 metre on each side.
- 17.3 Damage to cable is likely to occur if care is not taken in laying cable where the bed changes from solid support such as a foundation/masonry to soft support such as soft soil. The cable must not press against the edge of the solid support. The soft soil near the edge must be tamped and the cable raised slightly.

## **18. Cable termination**

- 18.1 The cable termination of signalling cables shall be undertaken by providing suitable location boxes/junction boxes on approved type termination.
- 18.2 All the core of the cable (used or spare) shall be terminated on approved type termination in cabin/SM's office or apparatus cases. Each core so terminated will be provided with identification ferrules with letters or/numbers embossed on them as per requirement of circuitry.
- 18.3 Termination of signalling cable on CT rack in relay room and in location boxes shall be done duly using identification marking on cable and on conductors/terminals. This will enable easy identification of conductors in case of any failures or cable disconnections or cable cut done by outsider/ miscreants. A proper marking and termination practice ensures quick and easy restoration during failures.
- 18.4 For quad cable, jointing may be done as per instructions of Telecom Directorate of RDSO. For jointing of signal cable in straight portion arrangement shall be issued by RDSO separately.

## **19. Testing of cable**

- 19.1 Before the cable is laid in the trench, a visual inspection of cable shall be made to see that there is no damage to the cable. It shall be tested for insulation and continuity of the cores. Thereafter, the cable shall be laid into the trench. Record of insulation and loop resistant must be maintained.
- 19.2 Testing of all main and tail cables after laying of the cable in trenches and also after termination in apparatus cases, in boxes and relay room shall be done.
- 19.3 Any defect noticed during the testing after laying the cable the same will be replaced.
- 19.4 All conductors in signalling cables must be tested for their insulation in dry weather every year as per instructions in para 20 below. A comparison of the test results between successive tests carried on a cable under similar conditions will give an indication of the trend towards deterioration of the insulating material over a period of time. If a sudden fall in insulation is observed, the cause shall be investigated and immediate steps taken up to repair or replace the cable.
- 19.5 In addition to the regular testing of cables in dry weather, random tests in wet weather may also be carried out, where considered necessary, to localise any sudden deterioration in insulation of cables.
- 19.6 After completion of any P.Way work in the vicinity of existing cable, testing of all cable may be undertaken to verify proper working of cable.

## **20. Instructions for insulation resistance testing of signalling cable**

### **20.1 General**

- 20.1.1 These instructions apply only to cables used for Railway Signalling and do not cover open line wires and internal wiring.
- 20.1.2 Insulation Resistance tests shall be made in such a manner that safe operation of trains is not affected. It shall be ensured that no unsafe conditions are set up by the application of test equipment.

- 20.1.3 All conductors in signalling cables must be tested for their insulation at the time of commissioning and thereafter in dry weather every year preferably during the same part of the year.
- 20.1.4 The insulation resistance tests shall be made when conductors, cables and insulated parts are clean and dry.
- 20.1.5 In addition to regular testing of the cables in dry weather, random tests in wet weather may also be carried out where considered necessary.
- 20.1.6 The conductors of the cables possess appreciable electrostatic capacity and may accumulate electrostatic charge. The cable conductors shall be shorted or earthed to completely discharge any accumulated charge (i) before connecting the insulation tester while commencing the test (ii) before the insulation tester is disconnected when the test is completed. This is in the interest of safety of personnel and protection of equipment
- 20.1.7 A 500V insulation tester shall be used for insulation testing. The fact that the cable has capacitance means that it has to be discharged before a measurement of the insulation resistance can be made. The insulation resistance shall therefore be recorded after the test voltage has been applied for one minute or so when the indicator of the insulation tester shows a steady reading.
- 20.1.8 Any metallic sheath or metal work of any rack or apparatus case shall be bonded to earth during test.

## 20.2 Procedure

- 20.2.1 Disconnect all cores of a cable at both ends. The disconnection may be made through links of approved type terminals, if provided.
- 20.2.2 Connect one terminal of the insulation tester to the conductor under test and other terminal to all the other conductors being bunched together and connected to earth.
- 20.2.3 Similarly test remaining conductors of the cable one by one.
- 20.2.4 Insulation Resistance so measured shall not be less than 5 mega ohms per kilometer at buried temperature. If the insulation resistance is found to be lower than 5 mega ohms, the cause shall be investigated and immediate steps taken



to repair or replace the cable to prevent any malfunctioning of the equipment and circuits.

20.2.5 The results of the insulation resistance tests shall be recorded in approved proforma. A comparison of test results between successive tests carried out on a cable under similar conditions will give an indication of the trend towards deterioration of the insulation resistance of the cable. If sudden fall in the insulation resistance is observed the cause shall be investigated and immediate steps taken to repair or replace the cable.

## **21. Supervision of cable laying**

21.1 The work shall be supervised at site personally by an official of the Signal & Telecommunication Department not below the rank of a JE/SE/SSE (Signal).

21.2 Orders will be given by the Inspector in charge only. He will be assisted by others at vulnerable places to inform him of the position and possible danger.

21.3 All concerned staff shall have full knowledge of their duties and the material handled by them.

21.4 No work shall be started unless all types of materials, tools consumable materials and staff are available. Location boxes and junction boxes shall be in position. If the cable ends are left in the ground unattended, damage is likely to take place.

21.5 Following record shall be maintained by JE/SE/SSE in-charge of the work/section:-

21.5.1 Cable route plan

21.5.2 Cable distribution chart

21.5.3 Cable termination diagram

21.5.4 Cable Testing Record : Summary Sheet, including supply details etc. as per **Annexure 2**.

21.5.5 Cable Insulation Resistance Test Sheet as per **Annexure 3**.

## **22. Special requirements in 25 kV AC electrified area**

22.1 Only unscreened cable shall be used.

- 22.2 Screened signalling cable may be used on signalling installations where screened cable is already in use and site condition demand its further use.
- 22.3 PVC insulated PVC sheathed and armoured unscreened cable to an approved specification (IRS-63) shall be used for carrying signalling circuits. Only approved type (IS-1554) power cable shall be used for signalling purposes.
- 22.4 The screened cable, if used, shall be PVC insulated, armored and to an approved specification IRS S-35.
- 22.5 The cable shall be so laid that it is not less than one meter from the nearest edge of the mast supporting the catenary or any other live conductor, provided the depth of the cable does not exceed 0.5 meters. When the cable is laid at a depth greater than 0.5 meters, a minimum distance of 3 meters between the cable and the nearest edge of the O.H.E structure shall be maintained. If it is difficult to maintain these distances, the cable shall be laid in concrete/heavy duty HDPE/Ducts or any other approved means for a distance of 3 meters on either side of the Mast. When so laid, the distance between the cable and the mast may be reduced to 0.5 meters. These precautions are necessary to avoid damage to the cable in the event of the failure of an overhead insulator.
- 22.6 In the vicinity of traction sub stations and feeding posts, the cable shall be at least one metre away from any metallic part of the O.H.E and other equipment at the substation, which is fixed on the ground, and at least one metre away from the substation earthing. In addition, the cable shall be laid in concrete or heavy-duty HDPE pipes/or other approved means for a length of 300 meters on either side of the feeding point. As far as possible, the cable shall be laid on the side of the track opposite to the feeding post.
- 22.7 In the vicinity of the switching stations, the cable shall be laid at least one metre away from any metallic body of the station, which is fixed in the ground, and at least 5 meters away from the station earthing. The distance of 5 meters can be reduced to one metre provided the cables are laid in concrete pipes/ heavy-duty HDPE pipes/ducts or any other approved means.
- 22.8 Where an independent Earth is provided for an OHE structure, i.e. where the mast is connected to a separate Earth instead of being connected to the rail, the cables shall be laid at least one metre away from the Earth.

22.9 Where there are O.H.E structures along the cable route, the cable trenches shall as far as possible, be dug not less than 5.5 meters away from the centre of the Track.

22.10 In a cable run, the number of circuits carrying 300V at any given instant shall not exceed three.

22.11 \*Note: 300 V feed system shall not be used in future installations.

### 23. Drawings for cable laying

23.1 The sketches for cable laying in different areas, soils, bridges etc. are listed below and are enclosed. However, Railways may issue detailed drawings as per local requirement of Railways and number and size of cables required.

S. N.	Description	Drawing No.	Annexure
1.	TYPICAL MAIN CABLE DISTRIBUTION PLAN FOR DOUBLE LINE (4 LINES) PI STATION	SDO/CABLE LAYING/001	Annexure-4
2.	POSITION OF TRENCHES FOR CABLE LAYING	SDO/CABLE LAYING/002	Annexure-5
3.	CABLE TRENCH	SDO/CABLE LAYING/003	Annexure-6
4.	LAYING OF SIGNALLING CABLE & TELECOM/ POWER CABLE IN SAME TRENCH	SDO/CABLE LAYING/004	Annexure-7
5.	RCC DUCT 300 MM	SDO/CABLE LAYING/005	Annexure-8
6.	RCC DUCT 500 MM	SDO/CABLE LAYING/006	Annexure-9
7.	RCC DUCT 500 MM	SDO/CABLE LAYING/007	Annexure-10
8.	LAYING OF CABLES IN ROCKY AREA	SDO/CABLE LAYING/008	Annexure-11
9.	TRACK CROSSINGS	SDO/CABLE LAYING/009	Annexure-12
10	ROAD CROSSINGS	SDO/CABLE LAYING/010	Annexure-13
11	CABLE LAYING ON CULVERTS WITH LOW FLOOD LEVEL	SDO/CABLE LAYING/011	Annexure-14
12	CABLE LAYING ON CULVERTS WITH HIGH FLOOD LEVEL	SDO/CABLE LAYING/012	Annexure-15
13	CABLE LAYING ON METALLIC BRIDGES	SDO/CABLE LAYING/013	Annexure-16

<b>S. N.</b>	<b>Description</b>	<b>Drawing No.</b>	<b>Annexure</b>
14	CABLE TROUGH FOR METALLIC BRIDGES	SDO/CABLE LAYING/014	Annexure-17
15	CABLE LAYING ON ARCH BRIDGES	SDO/CABLE LAYING/015	Annexure-18
16	BRICK MASONRY CHANNEL FOR ARCH BRIDGE	SDO/CABLE LAYING/016	Annexure-19
17	ARRANGEMENT OF JUMPER CABLE	SDO/CABLE LAYING/017	Annexure-20
18	CI CABLE MARKER & CONCRETING	SDO/CABLE LAYING/018	Annexure-21
19	CI CABLE MARKER	SDO/CABLE LAYING/019	Annexure-22
20	CONCRETE CABLE MARKER	SDO/CABLE LAYING/020	Annexure-23
21	METHOD OF UNROLLING CABLE	SDO/CABLE LAYING/021	Annexure-24
22	RULE MADE OF PIPE FOR MEASURING TRENCH DEPTH	SDO/CABLE LAYING/022	Annexure-25

**Annexure-1**

**JPO No. 1/SG/2004**

**(Issued under CRB's D.O. letter No. 2004/Sig/G/7 dated 17.12.2004)**

**JOINT PROCEDURE ORDER FOR UNDERTAKING DIGGING WORK IN THE  
VICINITY OF UNDERGROUND SIGNALLING, ELECTRICAL AND  
TELECOMMUNICATION CABLES**

- A. A number of Engineering works in connection with gauge conversion/doubling/third line are in progress on various railways, which require extensive digging work near the running track, in close vicinity of the working S&T cables carrying vital safety circuits as well as electrical cables feeding the power supply to Cabins, ASM room, RRI Cabin, Intermediate Block Huts (IBH) etc. Similarly, S&T organization under open line or construction units under CAO/C are executing various signalling and telecommunication works requiring digging of earth for laying of cables or casting of foundations for the erection of signal posts etc. RailTel are also executing the work of laying of quad cable and OFC on various Railways as a part of sanctioned works for exclusive use of Railways for carrying voice and data i.e. administrative and control communication, PRS, FOIS etc. or shared by RailTel Corporation of India Ltd. On certain sections digging is also required for laying of electrical cable and casting of foundation for the erection of OHE masts by Electrical Deptt. Generally, these works are executed by contractors employed .by these organizations.
- B. However, while carrying out these works in the vicinity of working signalling, telecommunication and electrical cables, at times, cable cuts take place due to JCB machines working along the track or during the digging work being done by Contractors carrying out the Civil Engineering Works. Similarly, such cable cuts are also resulting due to works undertaken by S&T or Electrical deptts. Such Cable faults results in the failure of vital signalling and telecommunication circuits.
- C. Henceforth, the following joint procedure shall be followed by Engineering, Electrical and S&T (and RailTel organization, wherever such works are being done by them) Officers of the respective divisions and by the Construction Organization, while carrying out any digging work near to existing signalling & telecommunication and electrical cables, so that the instances of cable cut due to execution of works can be controlled and minimized.

1. S&T Department (and RailTel, where they have laid the cables) & Electrical Deptts. shall provide a detailed cable route plan showing exact location of cable at an interval of 200m or wherever there is change in alignment so that the same is located easily by the Engineering official/contractor. This cable route plans shall be made available to the DSE/DEN or Dy. CE/C as the case may be by Sr. DSTE/DSTE or Sr. DEE/DEE of the divisions or Dy. CSTE/C or Dy. CEE/C within a reasonable time in duplicate. DSE/DEN or Dy. CE/C will send copies to their field unit i.e. AEN/SE/P.Way& works.
2. Before taking up any digging activity on a particular work by any agency, Sr. DSTE/DSTE or Sr. DEE/DEE of the section shall be approached in writing by the concerned Engg or S& T or Electrical officer for permitting to undertake the work. After ensuring that the concerned executing agencies including the Contractor have fully understood the S&T and Electrical cable route plan shall permit the work in writing.
3. After getting the permission from S&T or Electrical Deptt. as the case may be, the relevant portion of the cable route plan shall be attached to the letter through which permission is issued to the Contractor by concerned Engg. official for commencement of work and ensuring that the Contractors have fully understood the cable route plan and precautions to be taken to prevent damage to the underground cables. The Contractor shall be asked to study the cable plan and follow it meticulously to ensure that the safety of the cable is not endangered. Such a provision, including any penalty for default, should form part of agreement also. It is advisable that a suitable post of SE (Sig) or SE (Tele) or SE(Elect.) shall be created chargeable to the estimates of doubling / Gauge conversion, who can help engg. agencies in the execution of the work. However basic responsibility will be of the Department executing the work and the Contractor.
4. The SE (P.Way) or SE (Works) shall pass on the information to the concerned SE (Sig) or SE (Tele) or SE (Elect.) about the works being taken up by the Contractors in their sections at least 3 days in advance of the day of the work. In addition Engineering control shall also be informed by SE(P.Way) or SE (Works), which in turn shall pass on the information to the Test Room/Network Operation Centre of RailTel/TPC/Electrical Control.
5. On receiving the above information, SE (Sig) or SE (Tele) or SE (Elect.) shall visit the site on or before the date of taking up the work and issue permission

- to the Contractor to commence the work after checking that adequate precautions have been taken to avoid the damage to the cables. The permission shall be granted within 3 days of submission of such requests.
6. The name of the Contractor, his contact 'telephone number, the nature of the work shall be notified in the Engineering Control as soon as the concerned Engg. official issued the letter authorizing commencement of work to the Contractor. Test Room be given a copy and Test Room shall collect any further details from the Engineering Control and shall pass it on to S&T/RailTel& Elect. officials regularly.
  7. In case of works being taken up by the State Government, National Highway Authority etc., the details of the permission given i.e. the nature of work, kilometer etc. be given to the Engineering Control including the contact person's number so .that the work can be done in a planned manner. The permission letter shall indicate the contact numbers of Test Room/Network Operations Centre of RailTel/TPC/Elect. Control.
  8. Where the nature of the work taken up by the Engineering department is such that the OFC or other S&T cables or Electrical cables is to be shifted and relocated, notice of minimum one week shall be given so that the Division/RailTel/Construction can plan the works properly for shifting. Such shifting works shall, in addition, for security and integrity of the cables, be supervised by S&T supervisors / RailTel supervisors/ Electrical Supervisors.
  9. The concerned SE(P.Way)/SE(Works)/SE(Sig)/SE(Tele)/SE(Elect.) or RailTel supervisors, supervising the work of the Contractor shall ensure that the existing emergency sockets are not damaged in view of their importance in providing communication during accident/emergency.
  10. In case of minor nature of works where shifting of cable is not required, in order to prevent damage to the cable, the Engineering Contractor shall take out the S&T or optical fibre cable or Electrical cable carefully from the trench and place it properly alongside at a safe location before starting the earthwork under the supervision of SE (Sig) or SE (Tele) or SE (Electrical). The cable shall be reburied soon after completion of excavation with proper care including placement of the brick over the cable by the concerned S&T supervisors or Electrical Supervisors. However, the work will be charged to the concerned engineering work.

11. In all the sections where major project are to be taken up/going on RailTel/S&T Deptt. shall deploy their official to take preventive /corrective action at site of work.
12. No new OFC/Quad cable shall be laid close to existing track. It shall be laid close to Railway boundary as per extant instructions i.e. 1.0 m from the Railway boundary to the extent possible to avoid any interference with future works (doubling etc.). It shall be ensured in the new works of cable laying that the cable route is properly identified with electronic or Concrete markers. Henceforth, wherever cable laying is planned and before undertaking the laying work, the cable route plan of the same shall be got approved from the concerned Sr. DEN or Dy. CE/Constn. to avoid possible damages in future. Such approvals shall be granted within 7 days of submission of the requests.
13. The works of excavating the trench and laying of the cable should proceed in quick succession, leaving a minimum time between the two activities.
14. Any damage caused to OFC/Quad cable or Electrical cable during execution of the work, necessary debit shall be raised on Engineering Department who shall bear the cost of the corrective action.
15. All types of bonds i.e. rail bond, cross bond and structure bond shall be restored by the Contractor with a view to keep the rail voltage low to ensure safety of personnel.
16. Above joint circular shall be applicable for construction as well as open line organization of Engineering, S&T & Electrical.
17. The S&T cable and Electrical cable route plan should be got approved from the concerned Sr. DSTE/ DSTE & Sr. DEE/DEE respectively, before undertaking the work and completion cable route plan should be finalised Block section by Block section as soon as the work is completed.

-sd- -sd- -sd--sd-

**(R.S.Grover)(N.K.Goel)(R.C.Sharma)(R.Sundararajan)**  
**AM (Elec.)Adv (Sig)AM (Tele)AM (Works)**



**Annexure-2**

**CABLE TESTING RECORD: SUMMARY SHEET**

Cable No.		Cable Function	
Cable Size		Make	
Length		PO No. and date	
Between Locations		Inspection No. and Date	
Type of Protection		Spare Core Nos.	

SN	Date of Testing	Insulation Test Results		Ref. No. of Test Sheet*	Remarks and Signature
		Core to Core	Core to Earth		

\*Tests sheets for Insulation and Loop resistance results in matrix format to be maintained separately for each cable in the cable testing register.

**Annexure-3**

**CABLE INSULATION RESISTANCE TEST SHEET**

<b>Date of Meggering:</b>														<b>Signature</b>																	
(All figures in mega ohms unless otherwise specified)																															
No	1	2	3	4	5	6	7	8	9	10	11	12	13	14	15	16	17	18	19	20	21	22	23	24	25	26	27	28	29	30	
E																															
	1																														
		2																													
No	E		3																												
1		1		4																											
2			2		5																										
3				3		6																									
4					4		7																								
5						5		8																							
6							6		9																						
7								7		10																					
8									8		11																				
9										9		12																			
10											10		13																		
11												11		14																	
12													12		15																
13														13		16															
14															14		17														
15																15		18													
16																	16		19												
17																		17		20											
18																			18		21										
19																				19		22									
20																					20		23								
21																						21		24							
22																							22		25						
23																								23		26					
24																									24		27				
25																										25		28			
26																										26		29			
27																											27		30		
28																												28			
29																													29		
30																														30	

(All figures in mega ohms unless otherwise specified)

**Date of Meggering:** \_\_\_\_\_ **Signature** \_\_\_\_\_

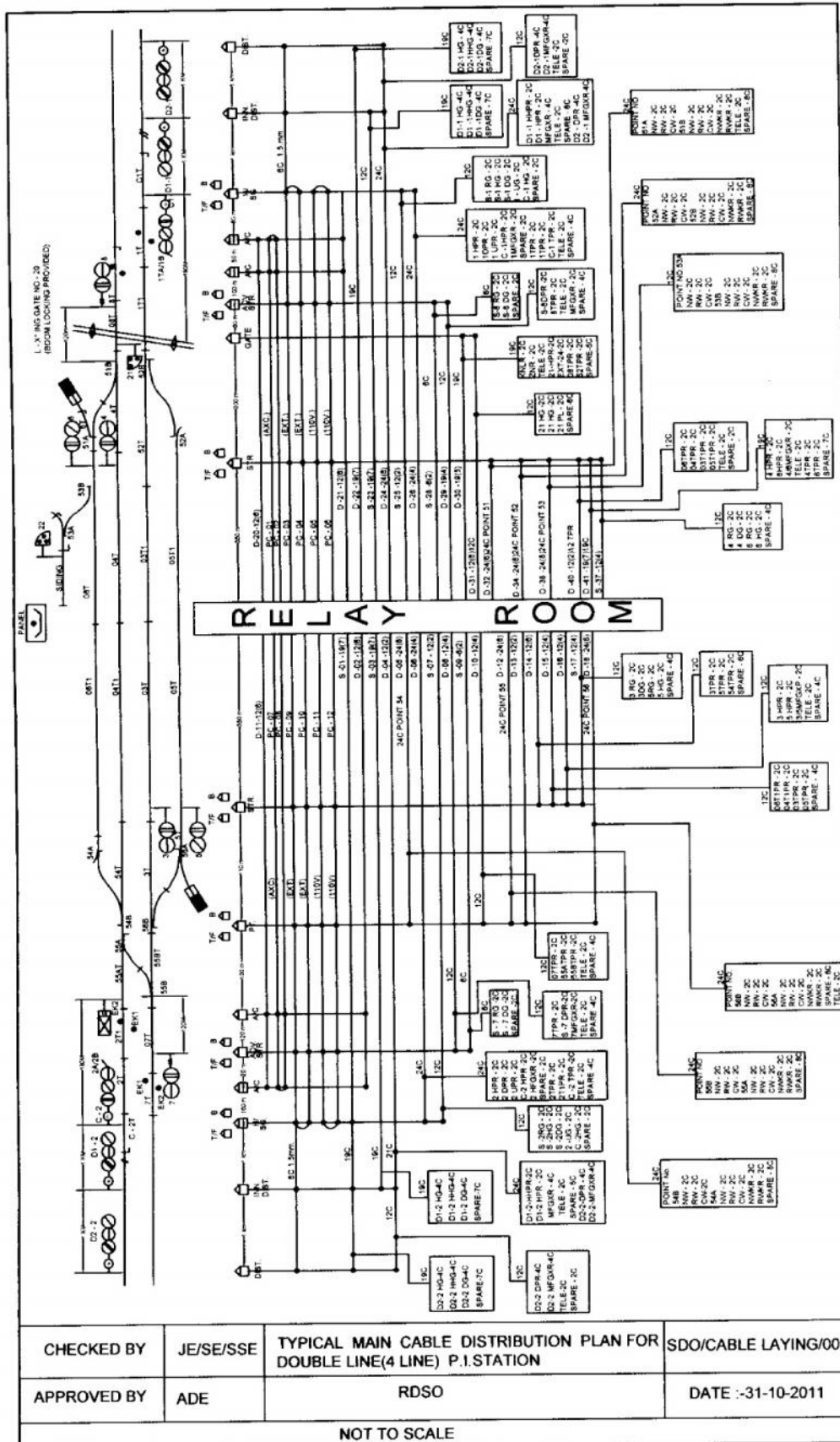

CHECKED BY	JE/SE/SSE	TYPICAL MAIN CABLE DISTRIBUTION PLAN FOR DOUBLE LINE(4 LINE) P.I.STATION	SDO/CABLE LAYING/001
APPROVED BY	ADE	RDSO	DATE :-31-10-2011
NOT TO SCALE			

Annexure-4

**Annexure-5**

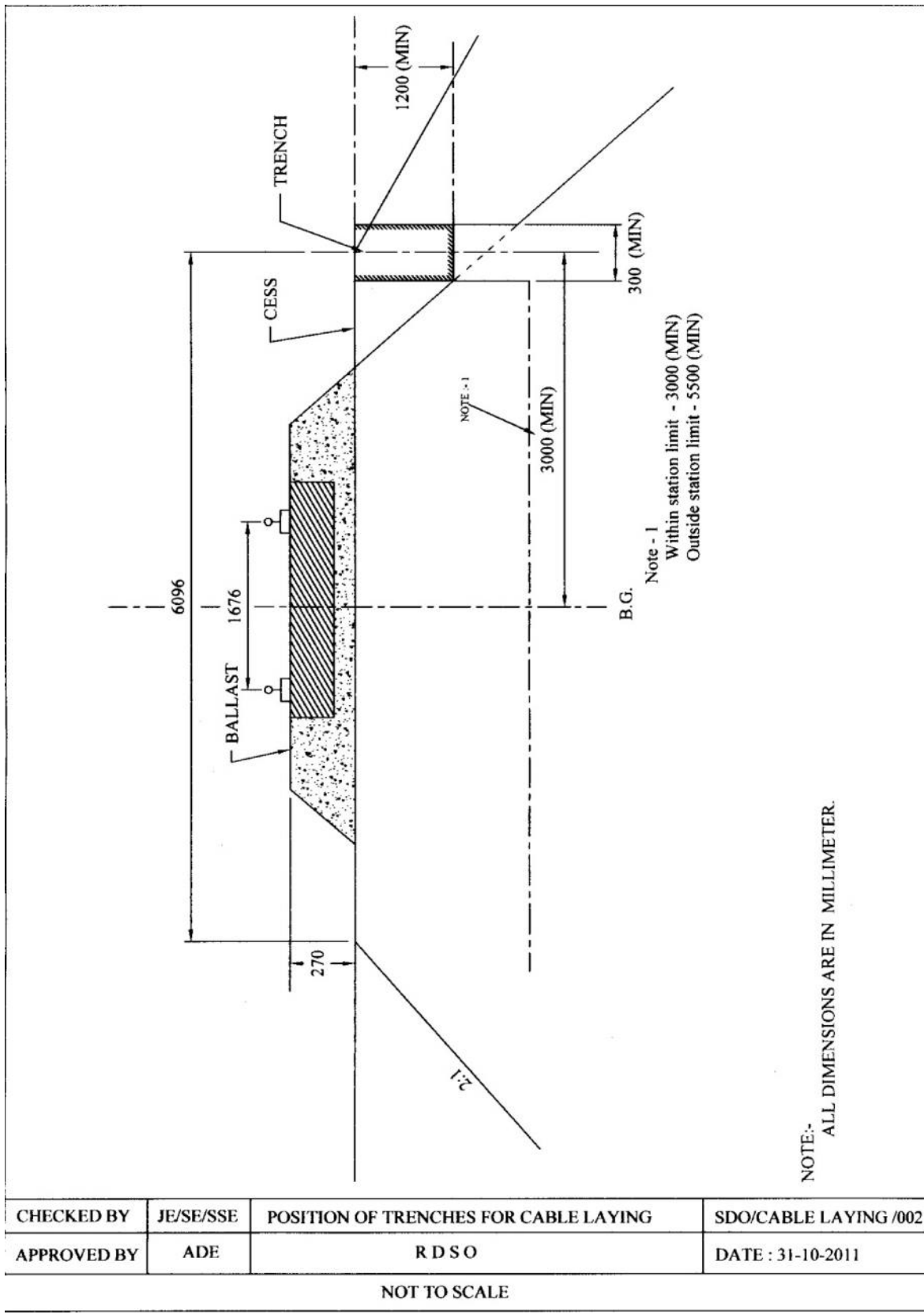

**Annexure-6**

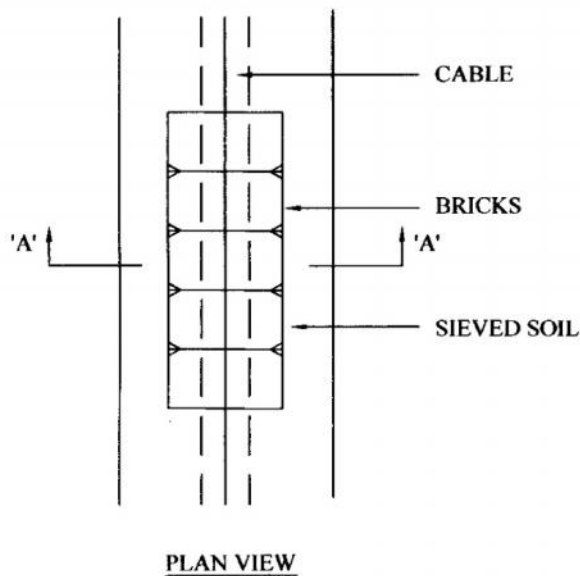
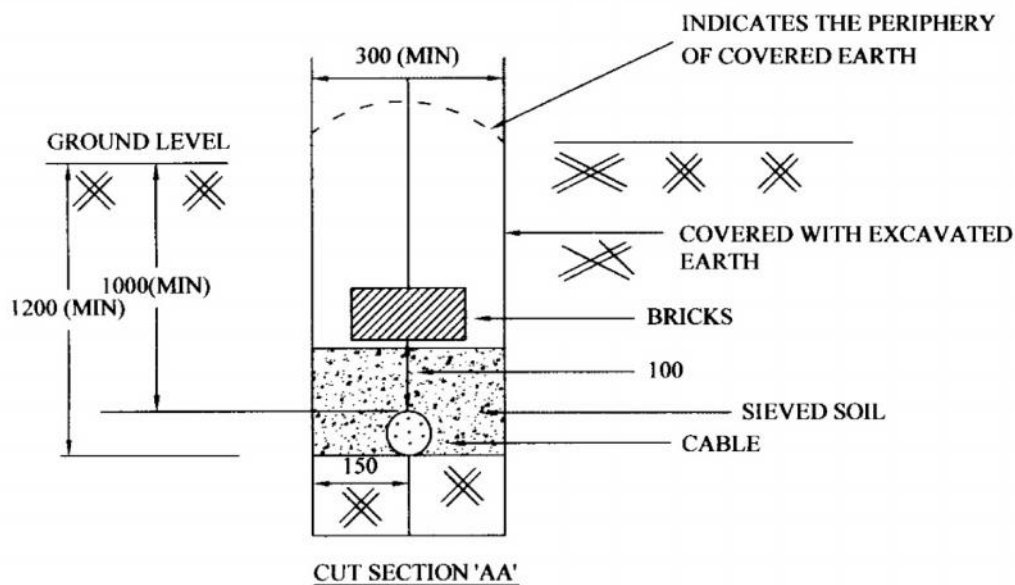

NOTE :  
 1. ALL DIMENSIONS ARE IN MILLIMETER.

CHECKED BY	JE/SE/SSE	CABLE TRENCH	SDO/CABLE LAYING/003
APPROVED BY	ADE	R. D. S. O.	DATE : 31-10-2011
NOT TO SCALE			

**Annexure-7**

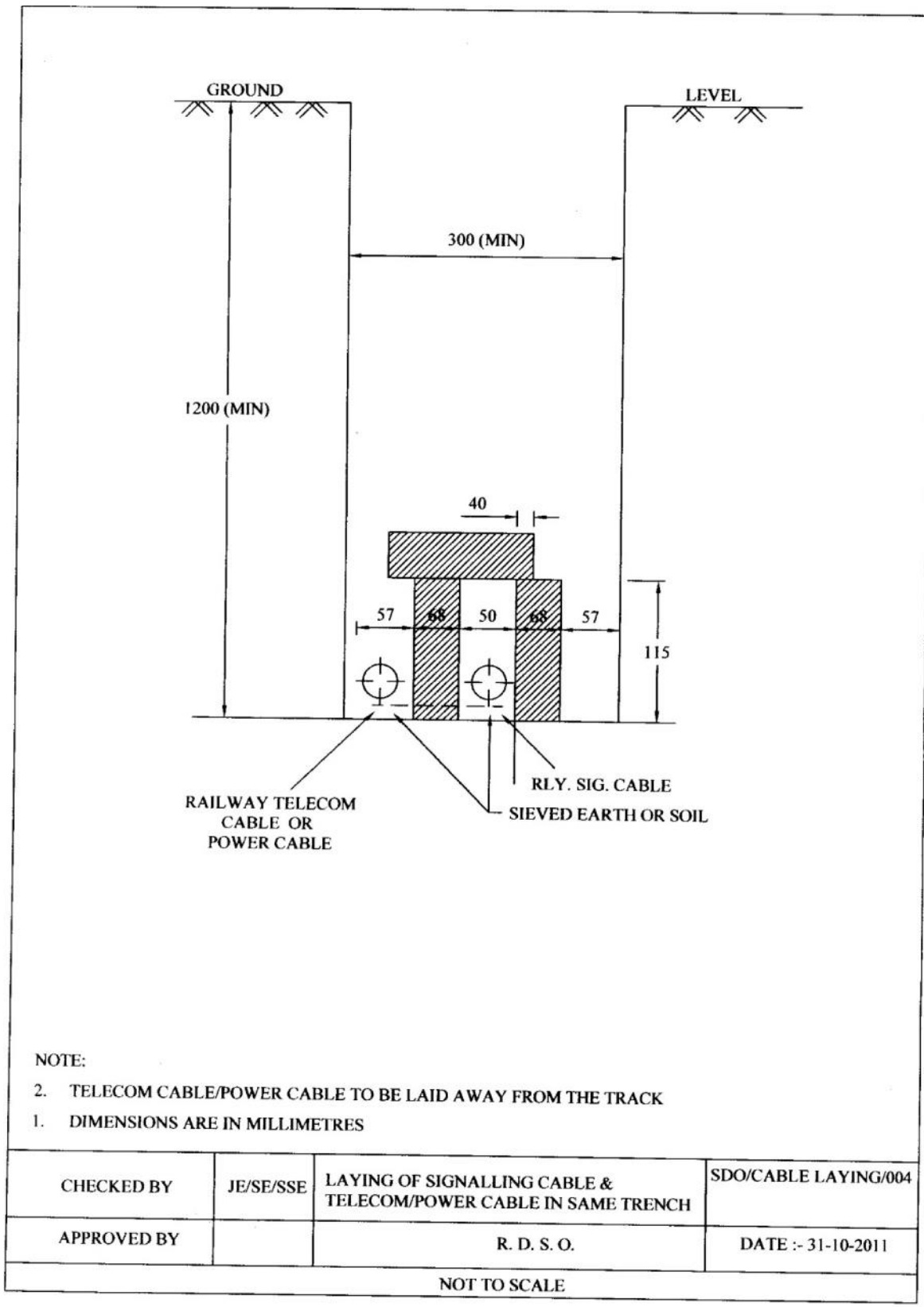

**Annexure-8**

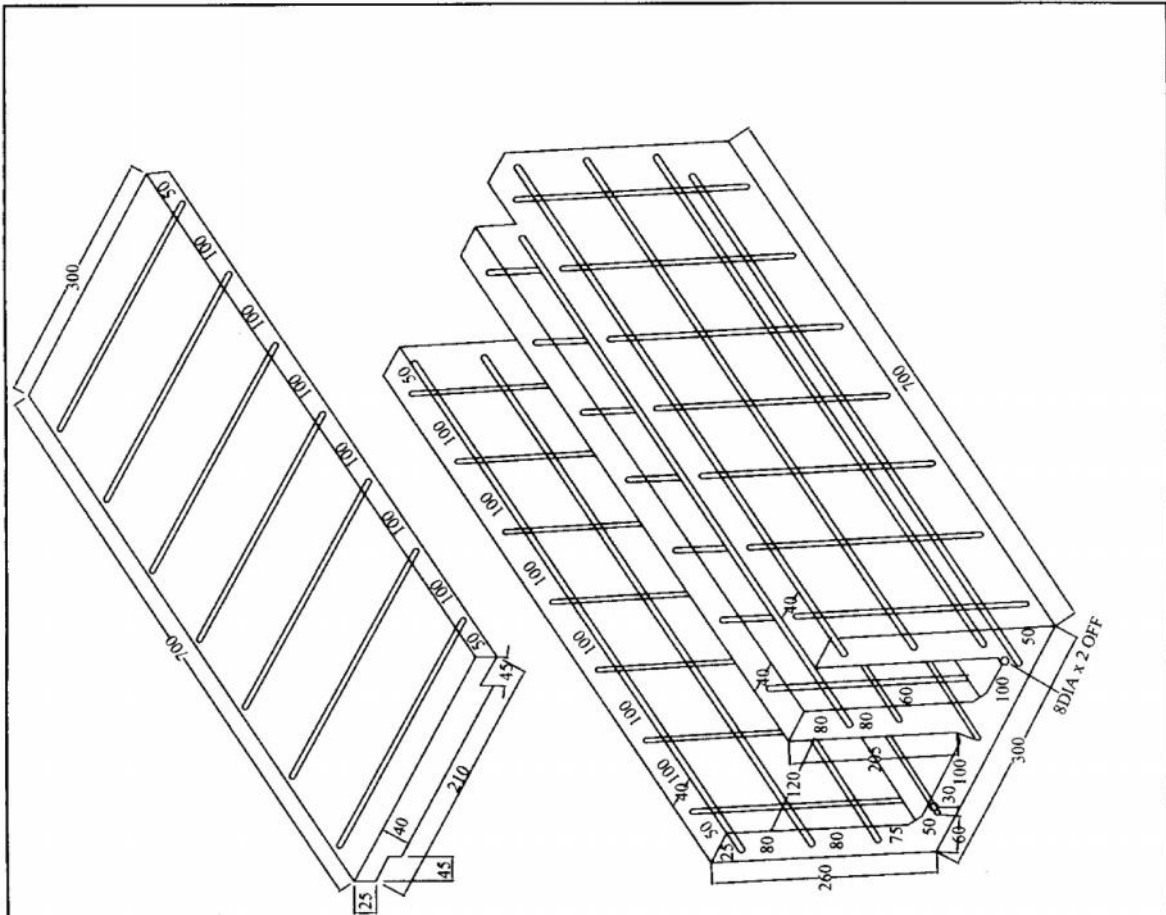

- Note :-
1. TRUNKING AND CAPPING ARE SUITABLE FOR BURYING ADJACENT TO THE TRACKS IN TRENCHES WITH MINIMUM DEPTH OF 600 mm.
  2. THE TRUNKING TO BE ALIGNED BY PUTTING AN MS ROD OF 8 mm DIA X 100mm LONG AS PER IS:432 PART
  3. (1)-1982 IN THE TWO HOLES PROVIDED.
  4. 6.0 mm DIA HIGH STRENGTH DEFORMED STEEL BARS CONFORMING TO IS:11786 TO BE USED FOR REINFORCEMENT
  5. M - 25 GRADE OF CONCRETE TO BE USED CONFORMING TO IS:10262 - 1982 AND IS:456 - 2000 - 10 mm SIZE COURSE AGGREGATE TO BE USED.
  6. OPC OF 43 GRDE TO BE USED CONFORMING TO IS:8112 - 1989.
  7. THE ACCEPTANCE TEST SHALL BE CONDUCTED IN A RECOGNISED LABORATORY AND THE COST OF THE TEST AS CHARGED BY THE LABORATORY SHALL BE BORNE BY THE CONTACTOR.
  8. CURING SHALL BE DOBE AS PER THE IS: 456:2000.
  9. DUCT MAY BE IN-SITU OR FACTORY MADE
  9. ALL DEMENSION ARE IN MILLIMETER

CHECKED BY	JE/SE/SEE	RCC DUCT 300 MM.	SDO/CABLE LAYING/005
APPROVED BY	ADE	R.D.S.O.	DATE :- 31-10-2011
NOT TO SCALE			

**Annexure-9**



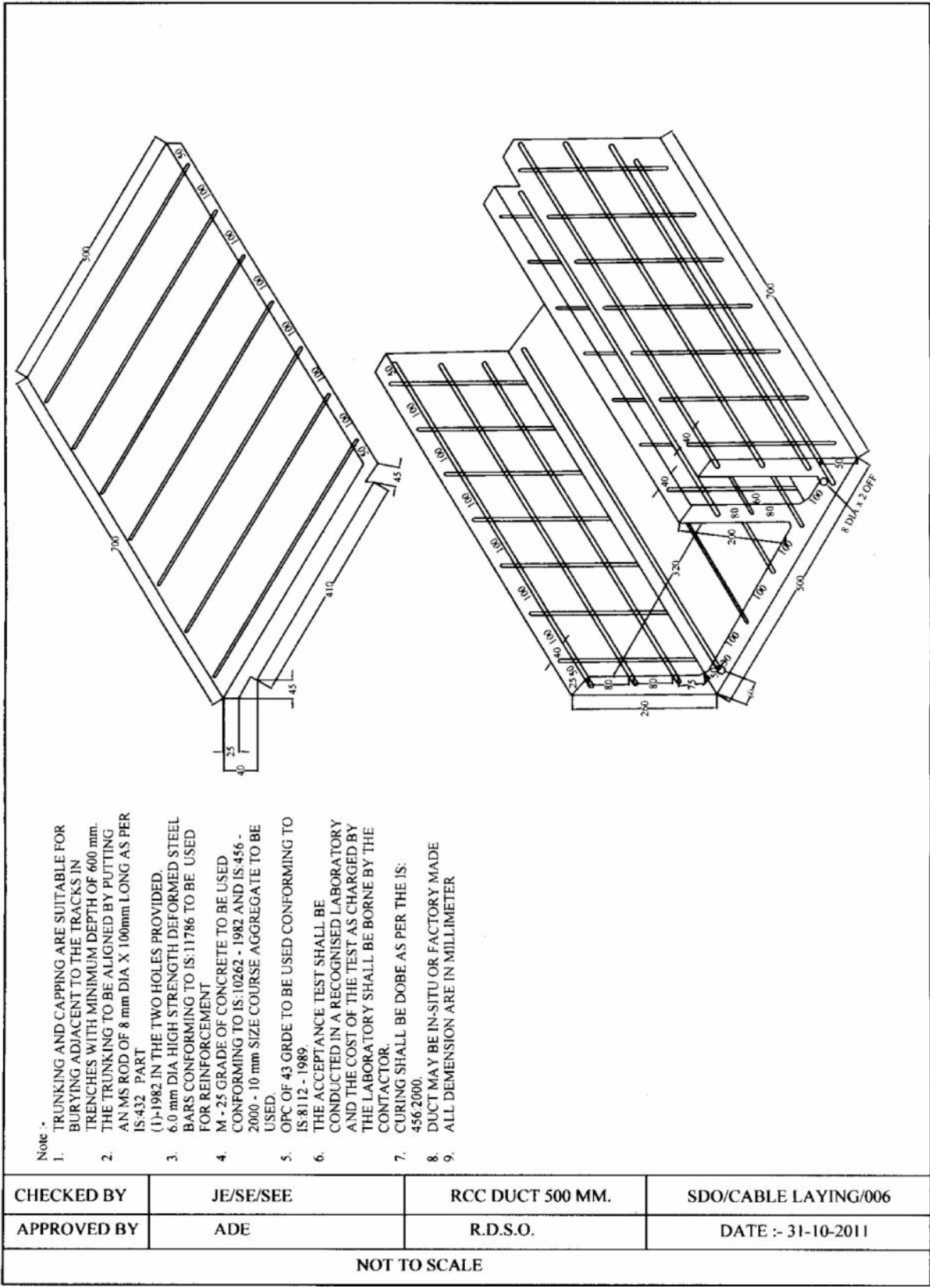

- Note :-
1. TRUNKING AND CAPPING ARE SUITABLE FOR BURYING ADJACENT TO THE TRACKS IN TRENCHES WITH MINIMUM DEPTH OF 600 mm.
  2. THE TRUNKING TO BE ALIGNED BY PUTTING AN MS ROD OF 8 mm DIA X 100mm LONG AS PER IS-432 PART
  3. (1)-1982 IN THE TWO HOLES PROVIDED. 6.0 mm DIA HIGH STRENGTH DEFORMED STEEL BARS CONFORMING TO IS:11786 TO BE USED FOR REINFORCEMENT
  4. M - 25 GRADE OF CONCRETE TO BE USED CONFORMING TO IS:10262 - 1982 AND IS-456 - 2000 - 10 mm SIZE COURSE AGGREGATE TO BE USED.
  5. OPC OF 43 GRDE TO BE USED CONFORMING TO IS:8112 - 1989.
  6. THE ACCEPTANCE TEST SHALL BE CONDUCTED IN A RECOGNISED LABORATORY AND THE COST OF THE TEST AS CHARGED BY THE LABORATORY SHALL BE BORNE BY THE CONTRACTOR.
  7. CURING SHALL BE DOBE AS PER THE IS: 456:2000.
  8. DUCT MAY BE IN-SITU OR FACTORY MADE
  9. ALL DEMENSION ARE IN MILLIMETER

CHECKED BY	JE/SE/SEE	RCC DUCT 500 MM.	SDO/CABLE LAYING/006
APPROVED BY	ADE	R.D.S.O.	DATE :- 31-10-2011
NOT TO SCALE			

**Annexure-10**

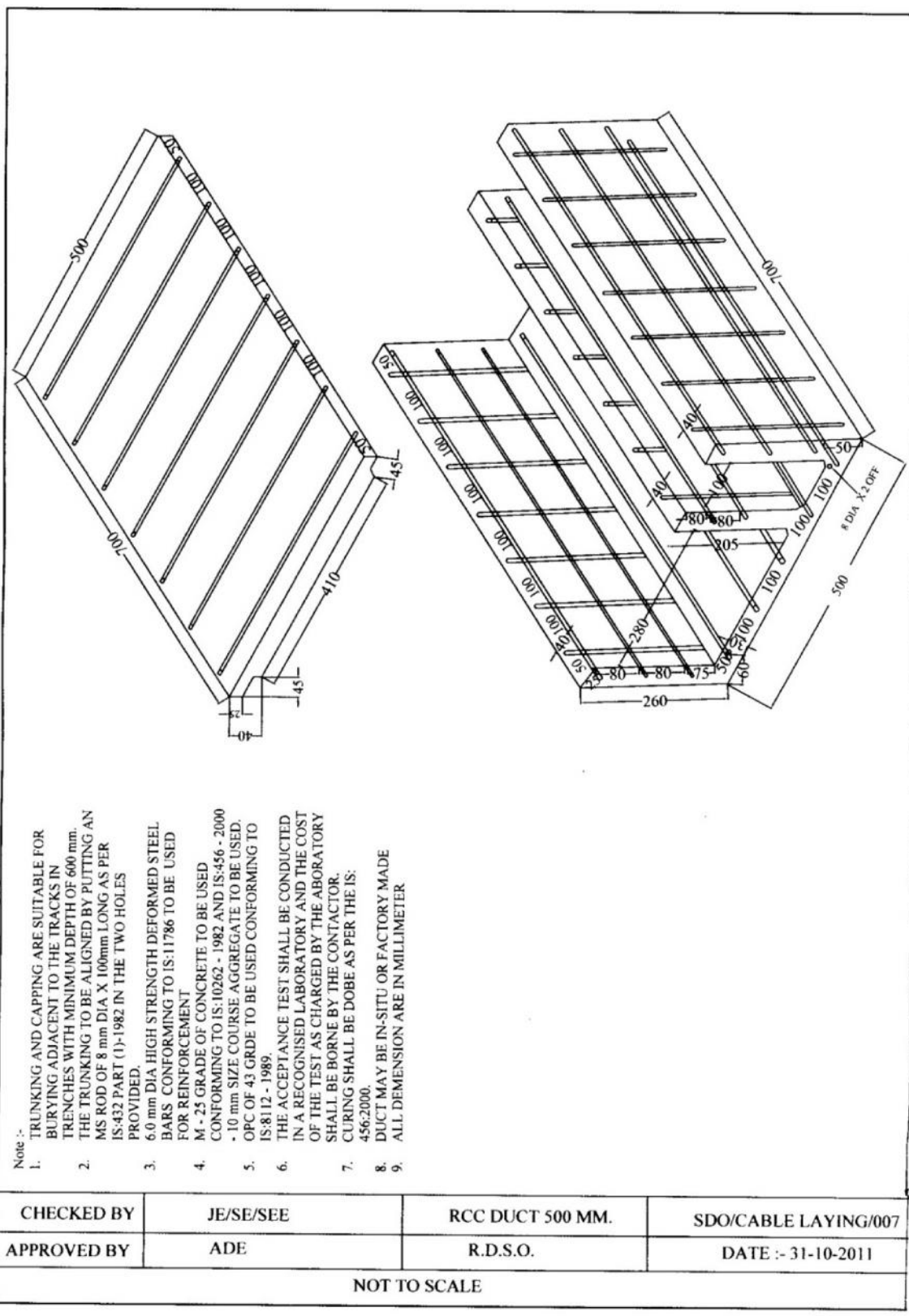

**Annexure-11**

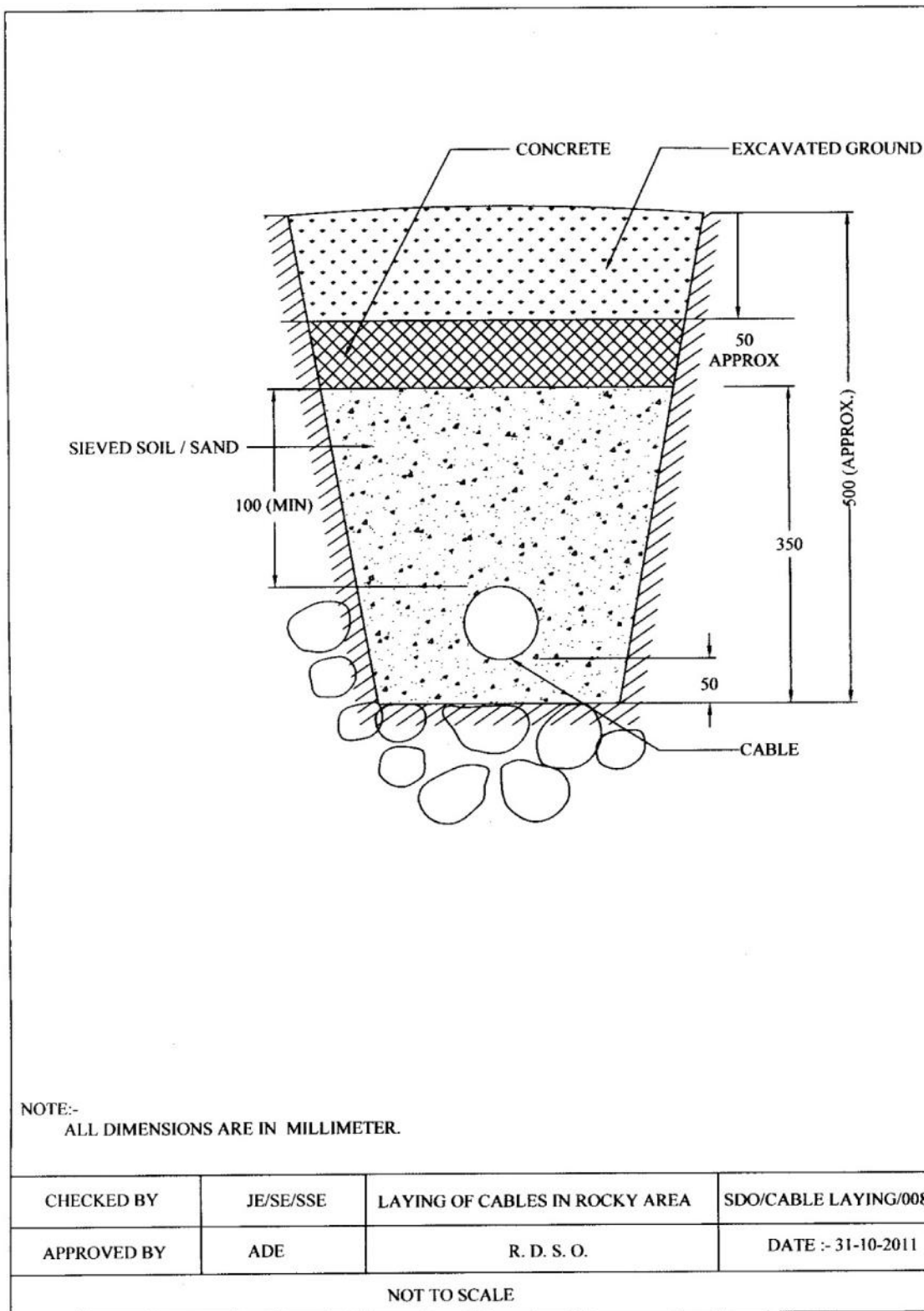

**Annexure-12**

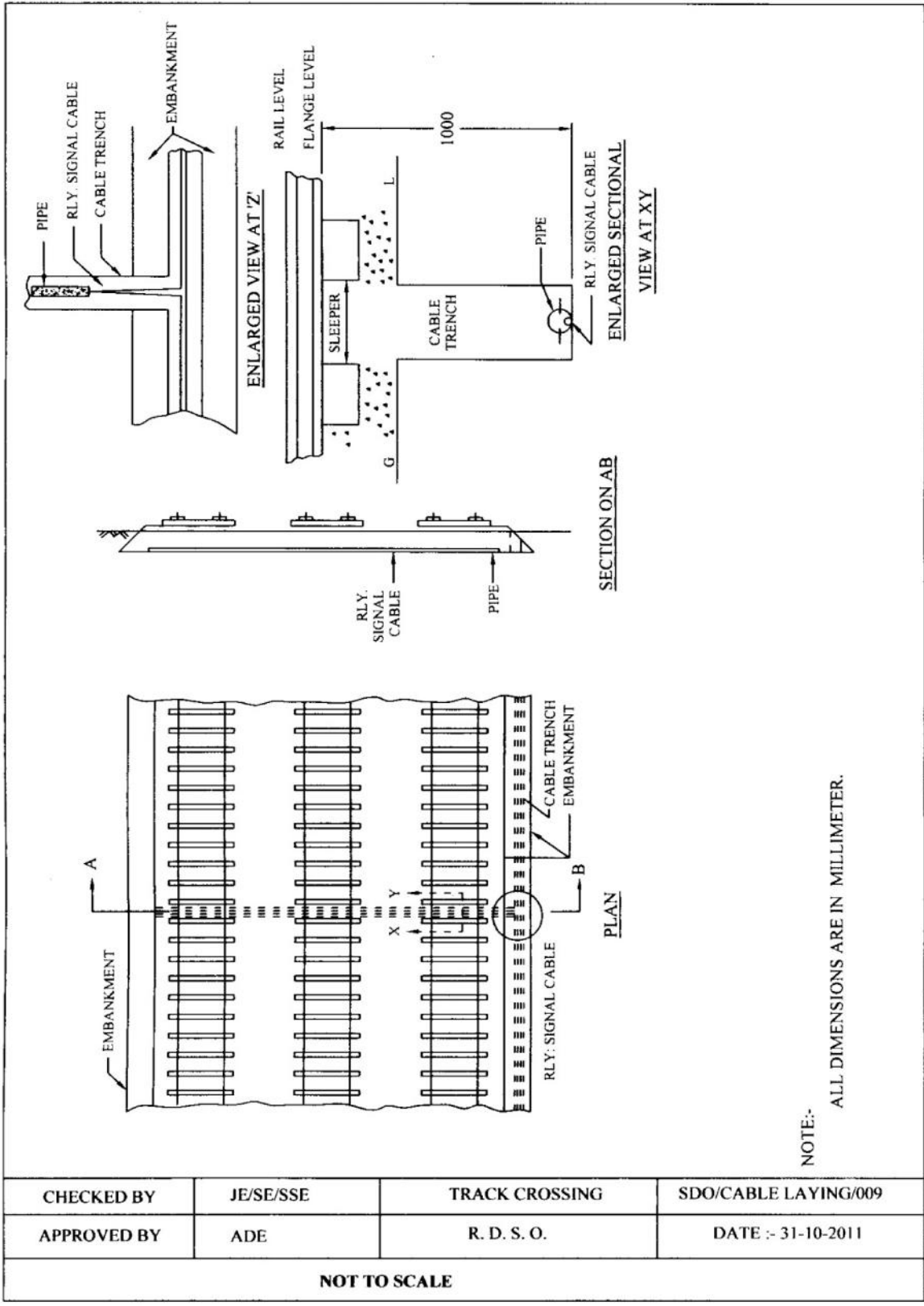

NOTE:-  
 ALL DIMENSIONS ARE IN MILLIMETER.

CHECKED BY	JE/SE/SSE	TRACK CROSSING	SDO/CABLE LAYING/009
APPROVED BY	ADE	R. D. S. O.	DATE :- 31-10-2011
<b>NOT TO SCALE</b>			

**Annexure-13**

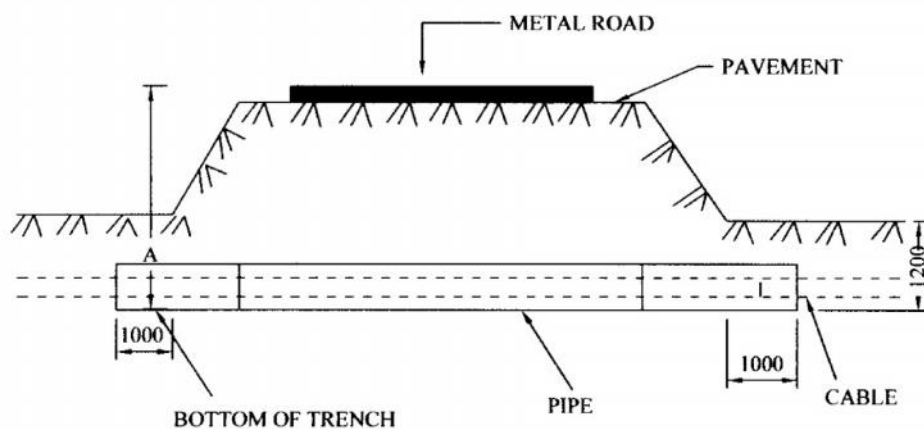

NOTE:-  
 ALL DIMENSIONS ARE IN MILLIMETER.

CHECKED BY	JE/SE/SSE	ROAD CROSSINGS	SDO/CABLE LAYING/010
APPROVED BY	ADE	R. D. S. O.	DATE :- 31-10-2011
NOT TO SCALE			

**Annexure-14**

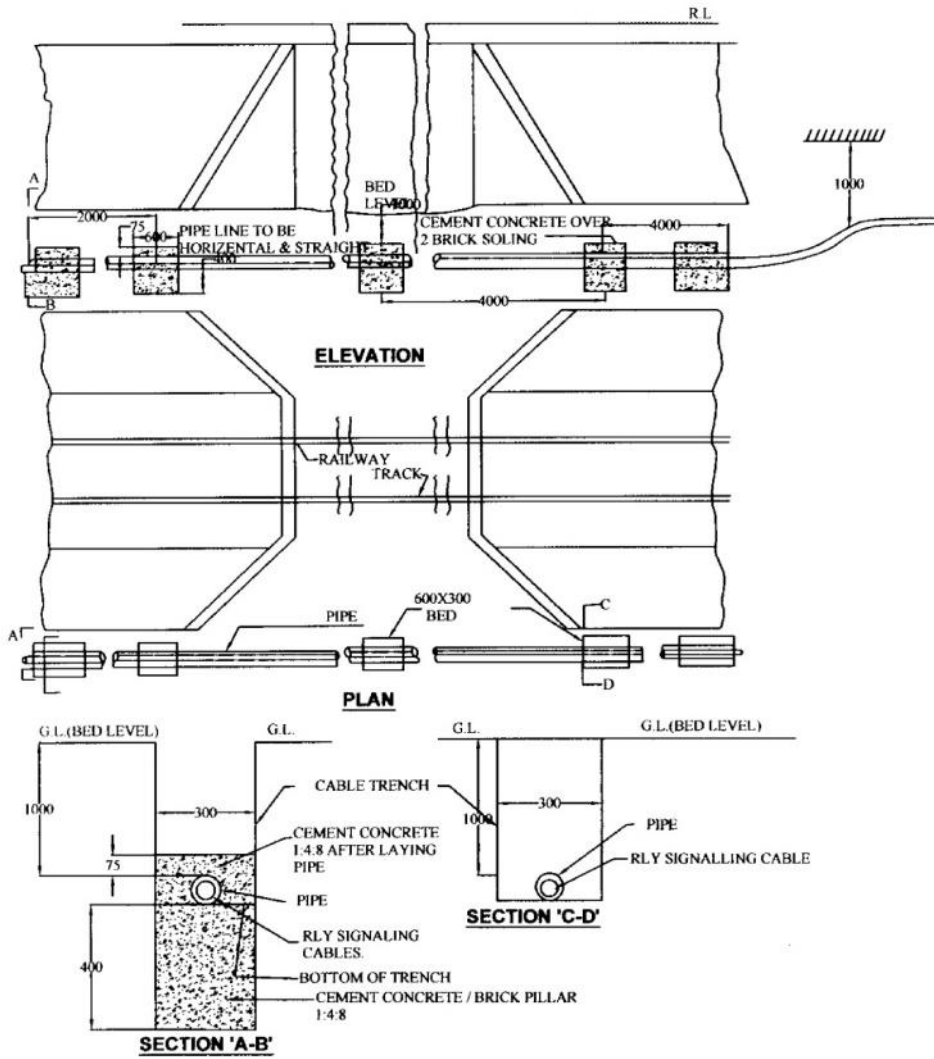

NOTE:-

ALL DIMENSIONS ARE IN MILLIMETER.

CHECKED BY	JE/SE/SSE	CABLE LAYING ON CULVERTS WITH LOW FLOOD LEVEL	SDO/CABLE LAYING/011
APPROVED BY	ADE	R.D.S.O	DATE :- 31-10-2011
NOT TO SCALE			

**Annexure-15**

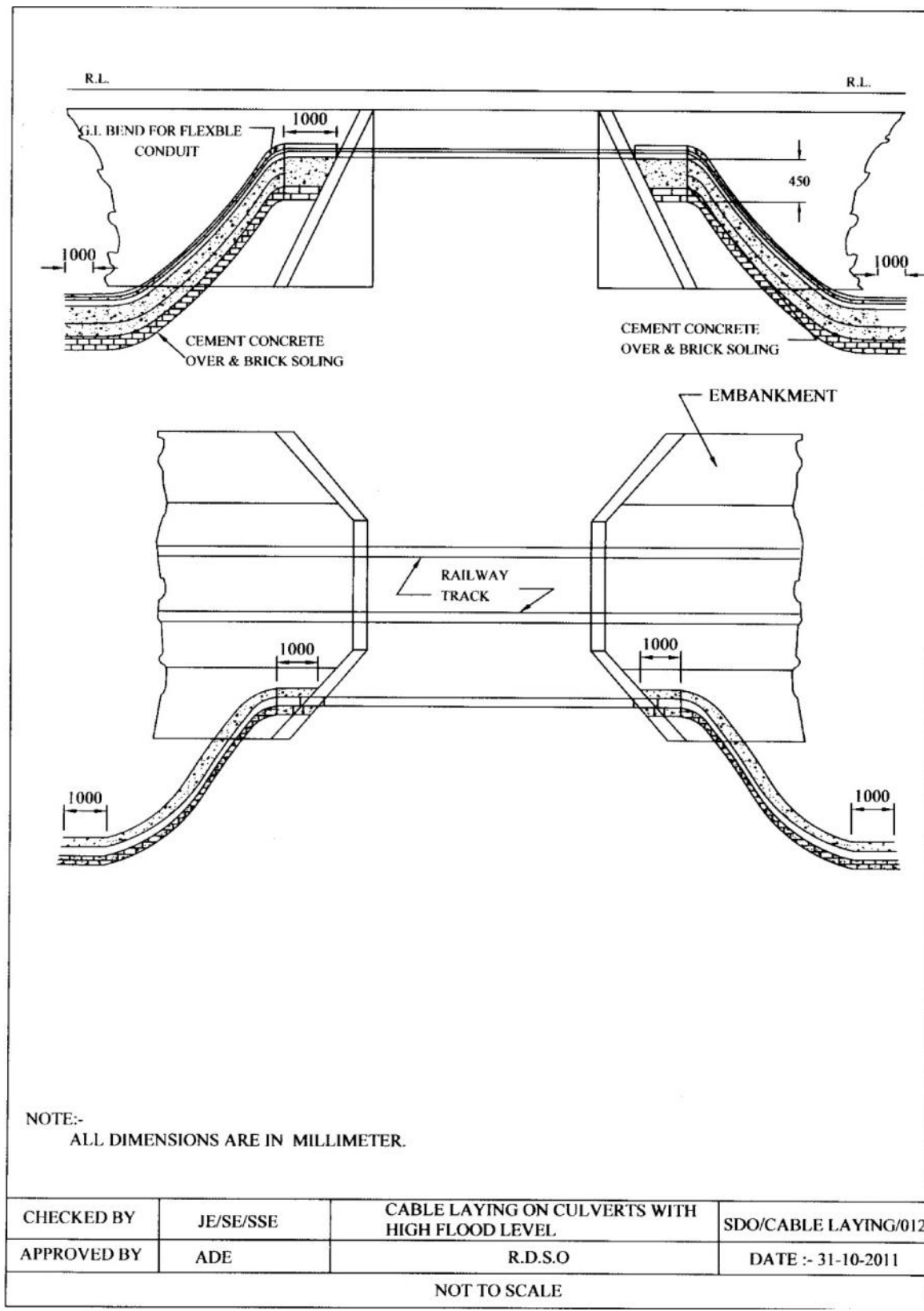

**Annexure-16**



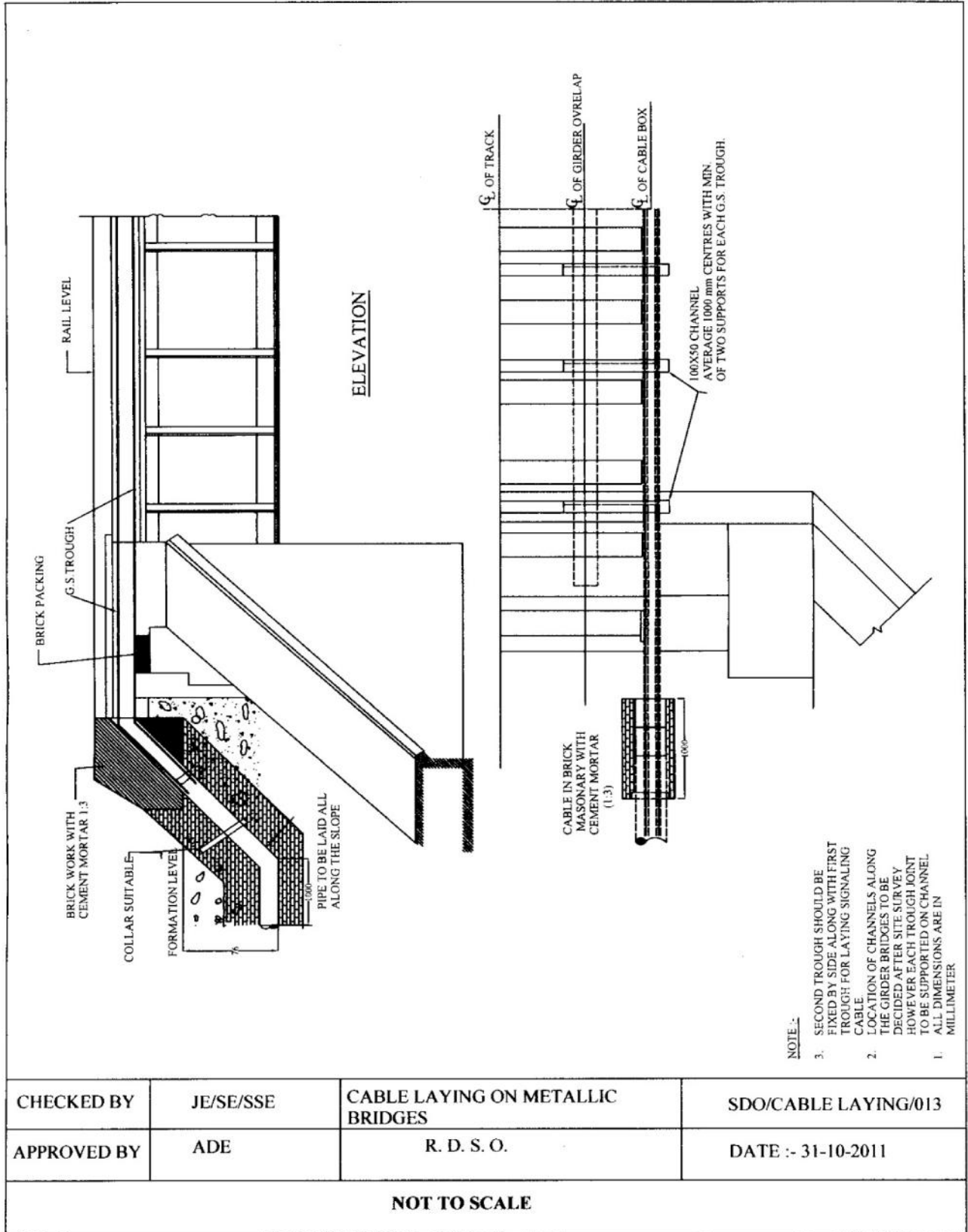

**Annexure-17**

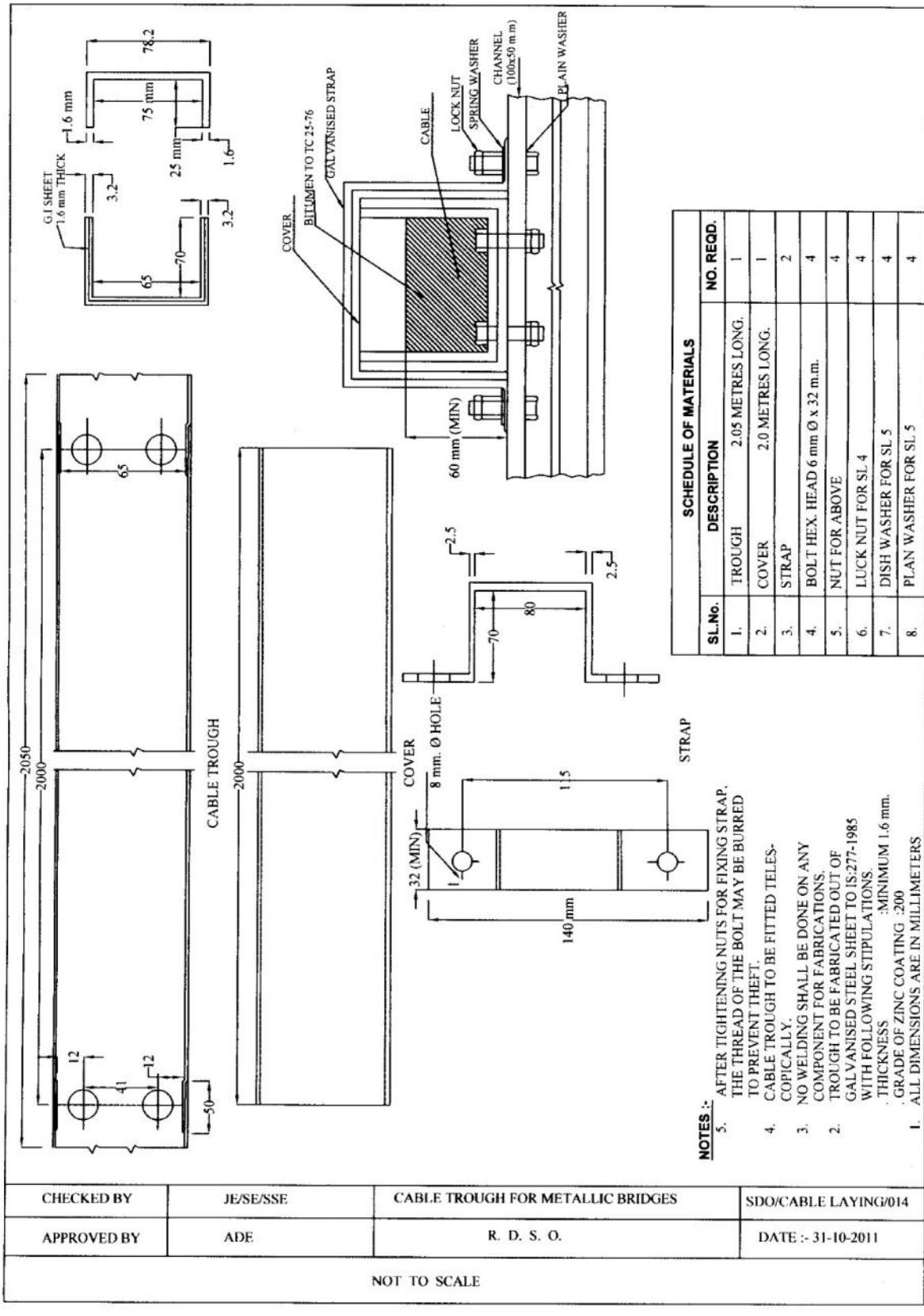

SCHEDULE OF MATERIALS		
SL.No.	DESCRIPTION	NO. REQD.
1.	TROUGH 2.05 METRES LONG.	1
2.	COVER 2.0 METRES LONG.	1
3.	STRAP	2
4.	BOLT HEX. HEAD 6 mm Ø x 32 m.m.	4
5.	NUT FOR ABOVE	4
6.	LUCK NUT FOR SL 4	4
7.	DISH WASHER FOR SL 5	4
8.	PLAN WASHER FOR SL 5	4

- NOTES :-**
1. ALL DIMENSIONS ARE IN MILLIMETERS
  2. GALVANISED STEEL SHEET TO IS:277-1985 WITH FOLLOWING STIPULATIONS.  
 THICKNESS : MINIMUM 1.6 mm.  
 GRADE OF ZINC COATING :200
  3. NO WELDING SHALL BE DONE ON ANY COMPONENT FOR FABRICATIONS.
  4. CABLE TROUGH TO BE FITTED TELESCOPICALLY.
  5. AFTER TIGHTENING NUTS FOR FIXING STRAP, THE THREAD OF THE BOLT MAY BE BURRED TO PREVENT THEFT.

CHECKED BY	JE/SE/SSE	CABLE TROUGH FOR METALLIC BRIDGES	SDO/CABLE LAYING/014
APPROVED BY	ADE	R. D. S. O.	DATE :- 31-10-2011

NOT TO SCALE

**Annexure-18**

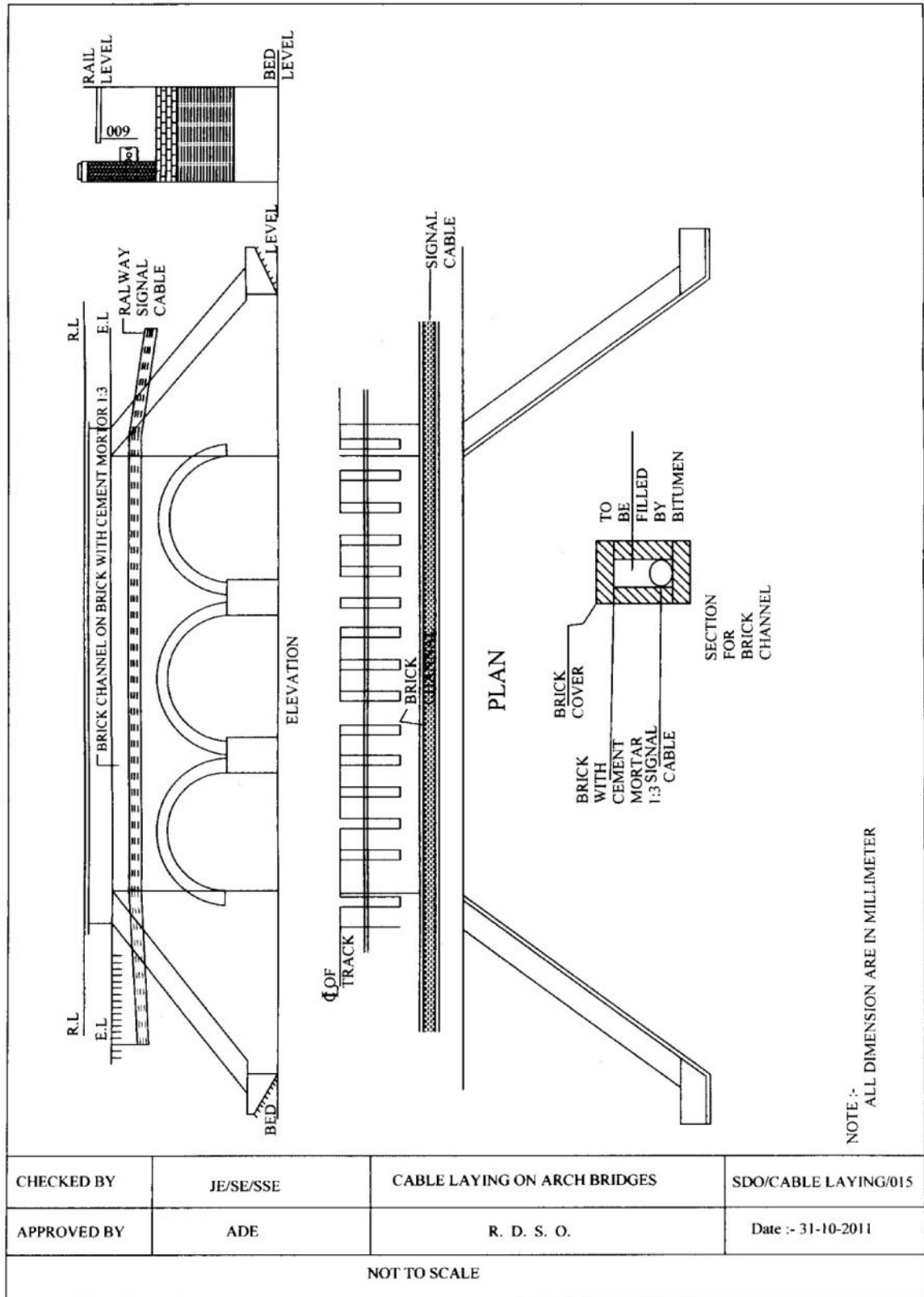

**Annexure-19**

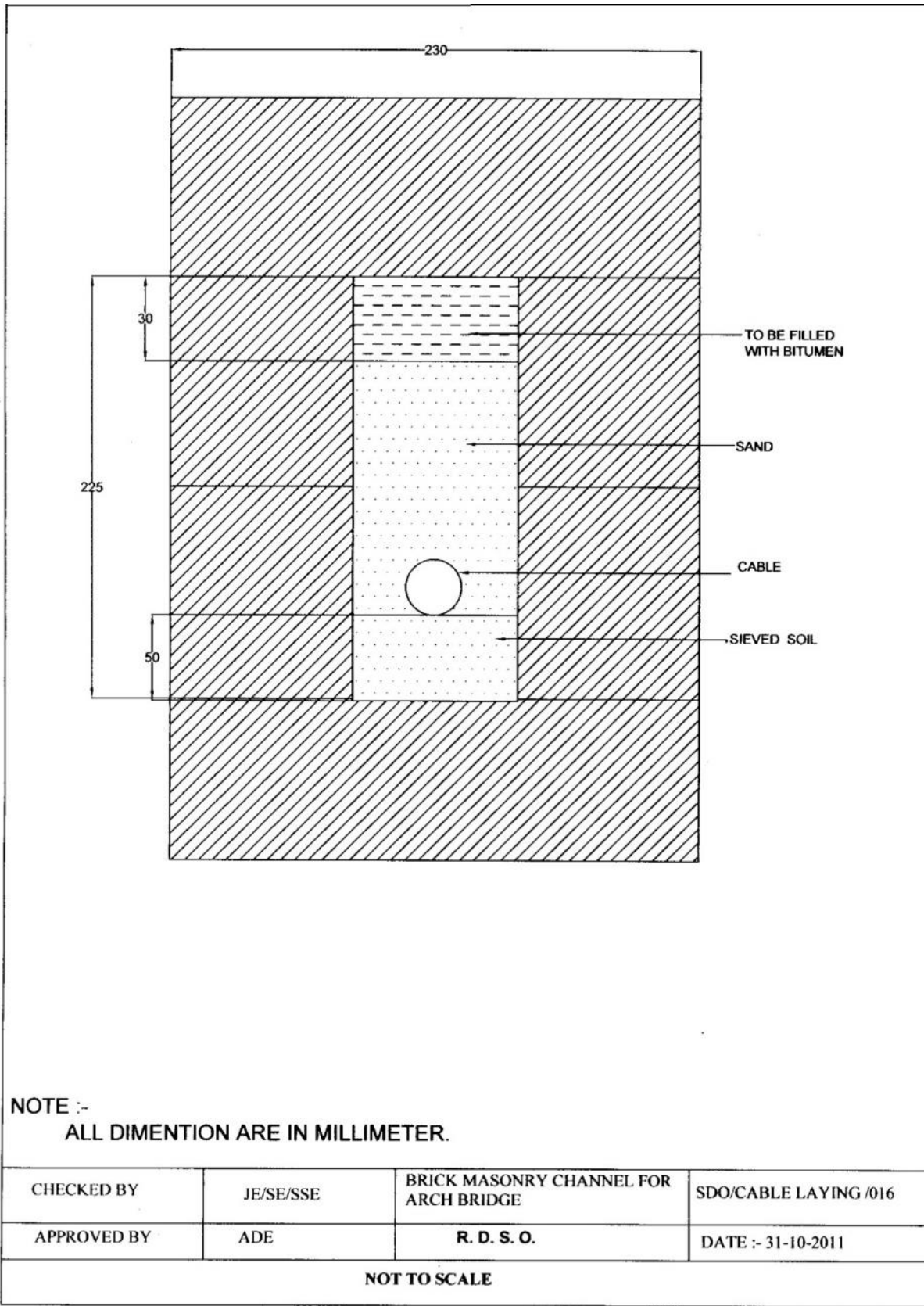

**Annexure-20**

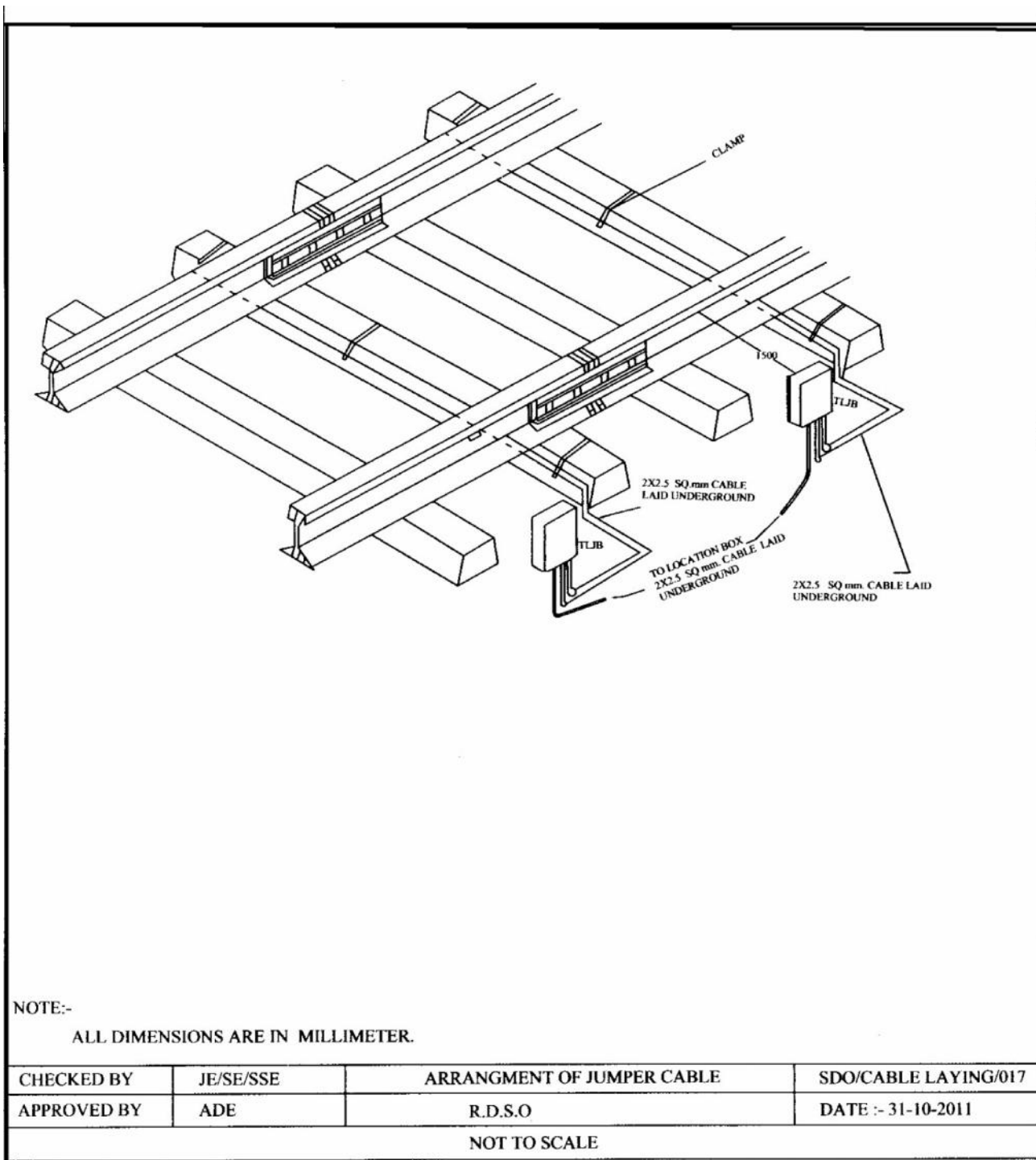

**Annexure-21**

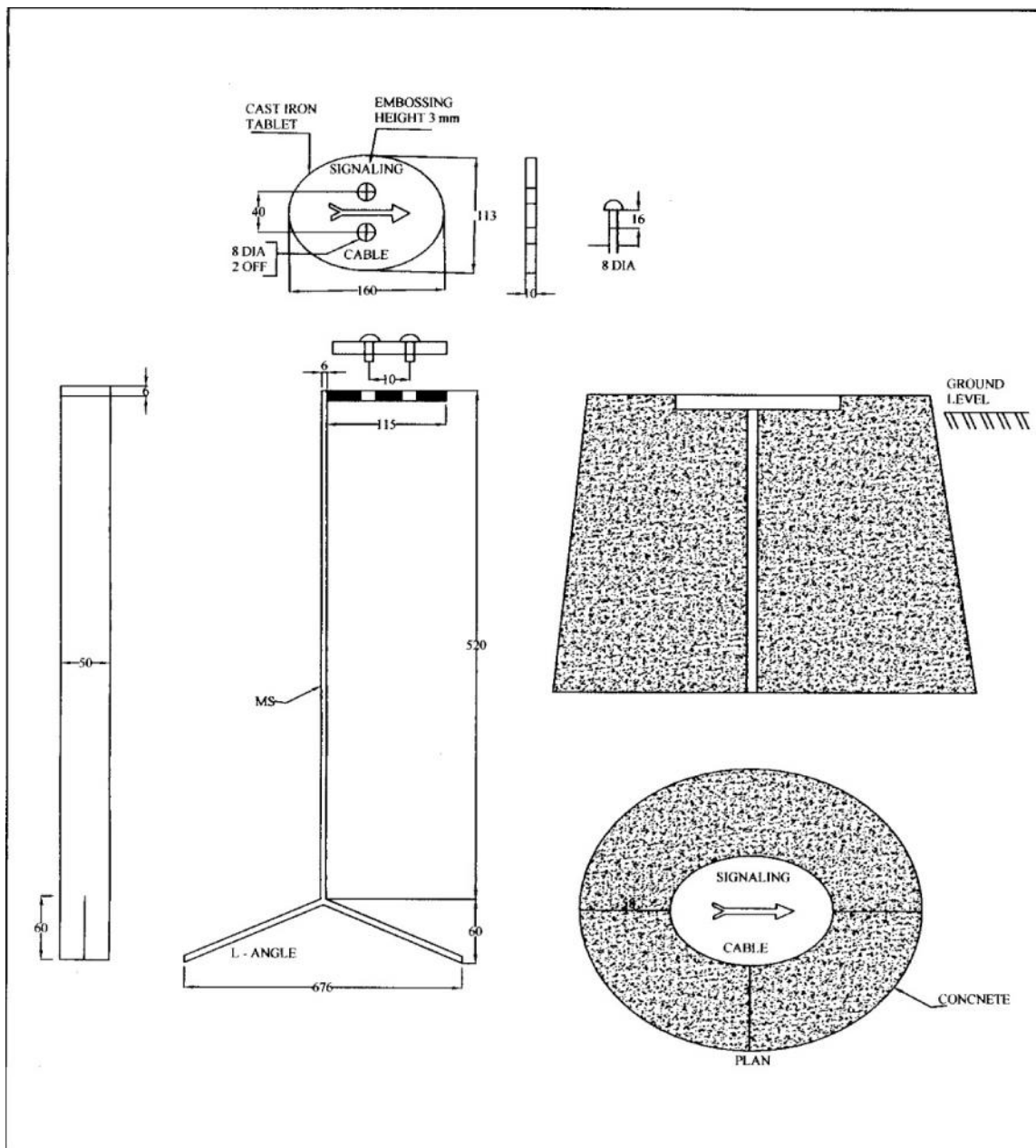

NOTE :-  
 1. ALL DIMENSIONS ARE IN MM.  
 2. CAST IRON TABLET IS TO BE RIVETTED TO THE L - ANGLE ON THE 2 HOLES

CHECKED BY	JE/SE/SSE	CI CABLE MARKER & CONCRETING	SDO/CABLE LAYING/018
APPROVED BY	ADE	R. D. S. O.	DATE :- 31-10-2011
NOT TO SCALE			

**Annexure-22**

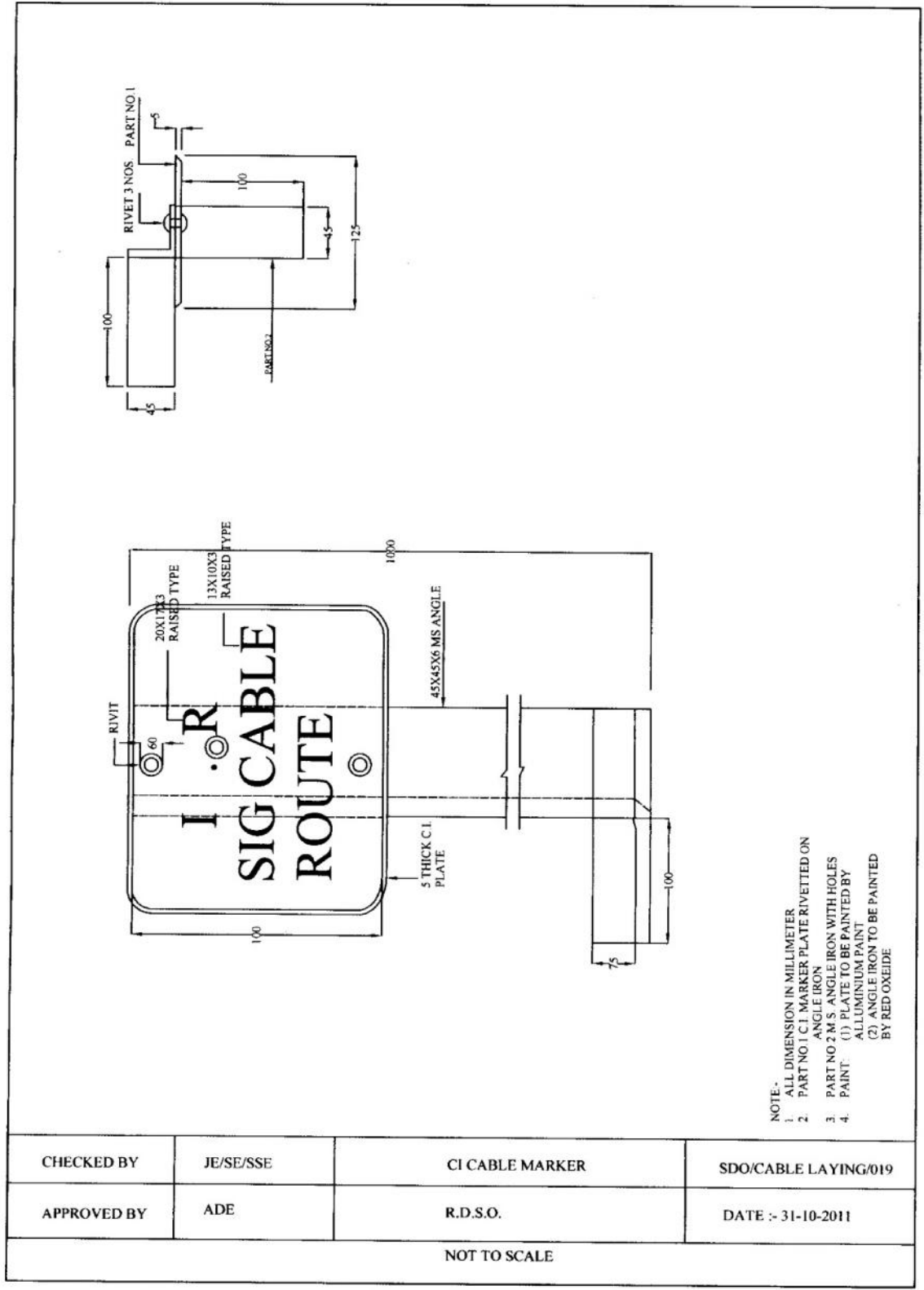



**Annexure-23**

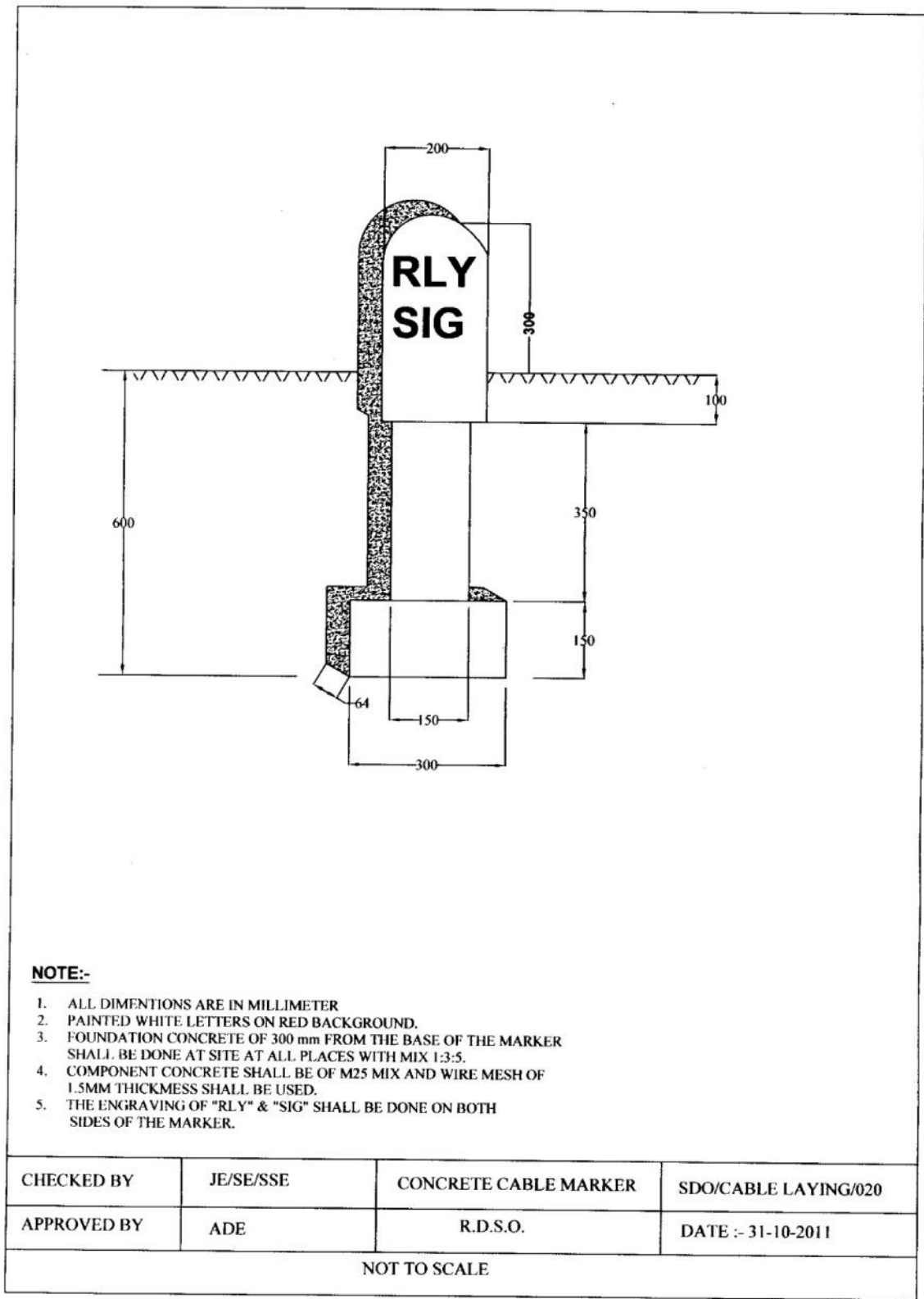

**Annexure-24**

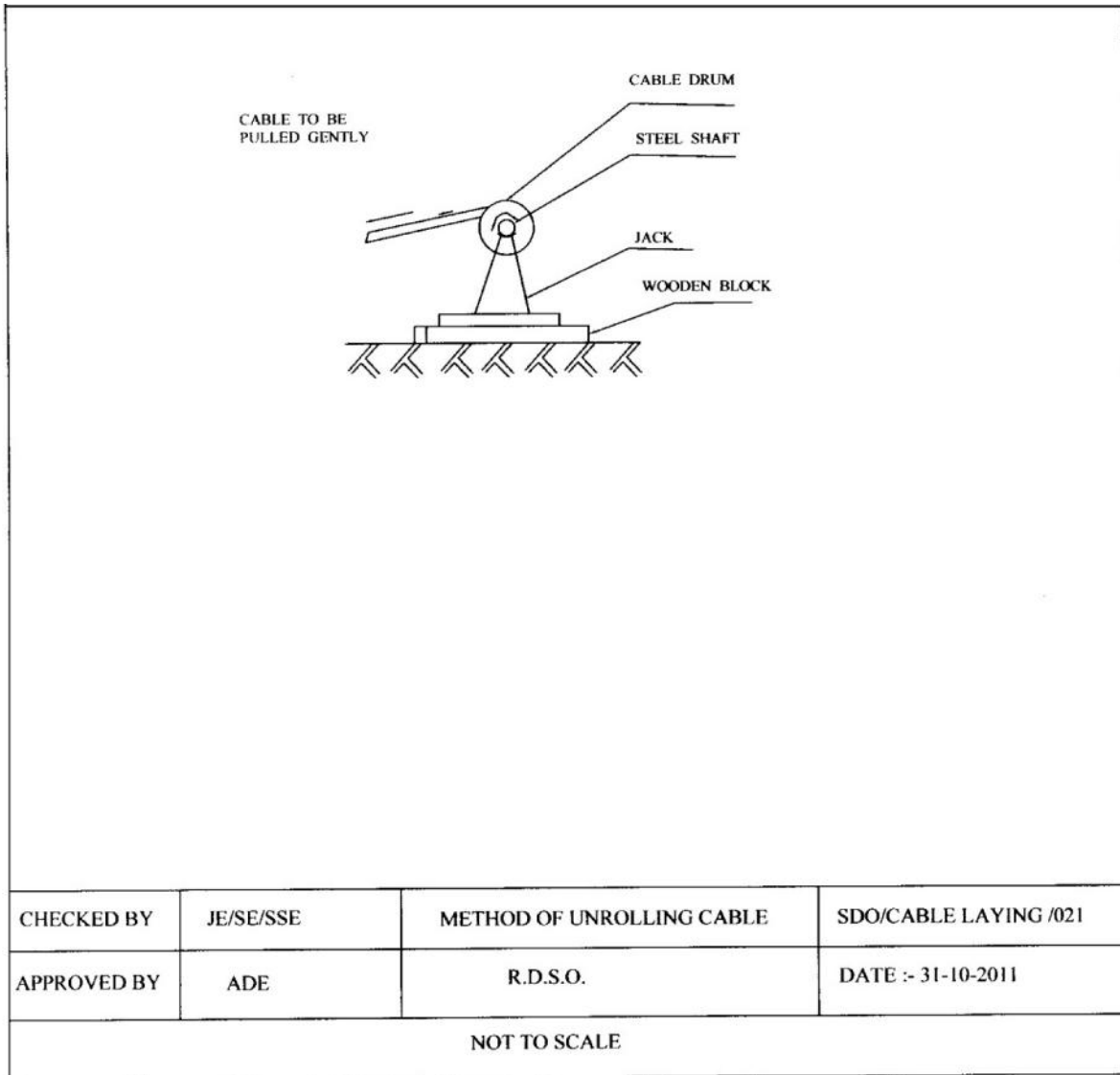

**Annexure-25**

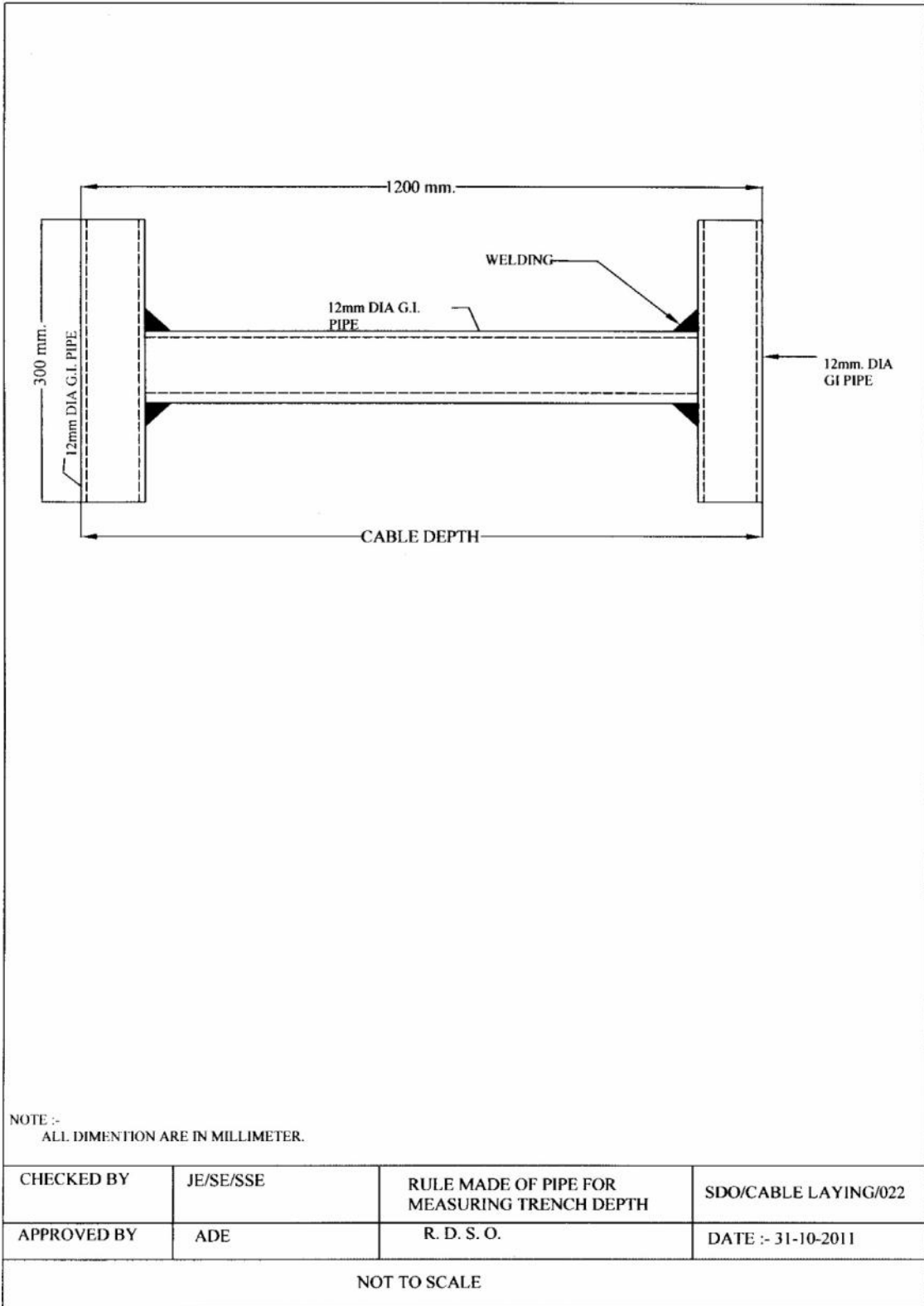

## ANNEXURE 10: SAFETY, HEALTH AND ENVIRONMENTAL (SHE) REQUIREMENTS

## **PART-I:SHE FRAMEWORK**

### **1 GENERAL**

- 1.1 The SHE requirements contain two major items: environmental and social protection and accident prevention and health promotion for all persons involved in and affected by the Works under this contract. Measures relating to the SHE requirements shall be taken by the Contractor in accordance with the requirements detailed in the Clauses herein. The clauses hereunder set out the Employer's requirements regarding the maintenance of human health and safety and protection of the natural and social environment, during design and implementation of the Works, until completion of the Contract.
- 1.2 First, under the SHE requirements, the Contractor shall establish measures to carry out his design and construction process to the highest standards of environmental and social practices and to comply with all relevant Indian environmental and social laws, standards, codes and regulations. The Contractor shall incorporate the principles of good environmental practice and minimizing negative environmental and social impacts into the Works contained in the Contract.
- 1.3 Second, the Contractor shall at all times be solely responsible for maintaining the safety and health of all his employees and of the general public whilst exposed to construction activities whether on or off-site. The Contractor shall take reasonable precautions to maintain the safety and health of all his employees during working hours in the Work Areas and during other hours in his employee's accommodation camps.

### **2 OBLIGATIONS**

#### **2.1 Scope**

- 2.1.1 The Contractor shall be solely and completely responsible for environmental and social impacts induced by the Works under consideration/investigation, design and construction and also responsible for safety and health conditions in the Work Area, including the safety of all persons involved in and affected by the Works, until the completion of the Contract. These requirements shall not be limited to normal business hours or other time constraints, nor be reduced or diminished in any way because the Contractor is not given sole occupation of the Work Area after the possession of the Site and/or legitimate possession of the Work Areas outside the Right of Way (ROW) such as Contractor's Borrow Pits and/or Quarries.

#### **2.2 Management Plans**

- 2.2.1 The Contractor shall formulate a SHE Policy and submit it within a period of 28 days after the Commencement Date. He shall obtain approval from Director General (DG) of Ministry of Labour, Govt. of India within a period of 42 days of Engineer's No-objection of the Policy. He shall immediately thereafter, arrange to display it at conspicuous places at work sites in Hindi and a local language understood by the majority of construction workers.
- 2.2.2 Within 42 days after the commencement date, the Contractor shall submit a detailed and comprehensive SHE Plan. The SHE Plan shall include detailed policies, procedures and regulations which, when implemented, will ensure compliance of the contract provisions as specified in Attachment 1 [Contents of SHE Plan] to Clause 16

[SHE Requirements] of Specifications.

2.2.3 As to environmental and social protection, the following plans shall be supplemented to the SHE Plan.

- (1) Environmental and Social Management Plan (ESMP): The Contractor shall prepare an ESMP setting out in detail how he proposes to manage and minimize the environmental and social impacts of his activities throughout Design and Construction Phases until the completion of the Contract. The Contractor shall submit an ESMP for consent by the Engineer within 42 days after the Commencement Date. The ESMP shall have the content and format specified in Attachment 2 [Contractor's Environmental and Social Management Plan] to Clause 16 [SHE Requirements] of Specifications. The Contractor shall amend and improve the ESMP addressing comments made by the Engineer and submit final ESMP within 28 days of the receipt of comments. Following receipt of the Engineer's written notice of "no objection", the plan will become the Contractor's ESMP with which the Contractor shall accomplish one of the obligations as required herein.
- (2) Environmental and Social Monitoring Plan (ESMoP): The Contractor shall prepare an ESMoP setting out in detail how he proposes to monitor in order to: ensure that all specified mitigation measures that are the Contractor's responsibility are implemented; that the measures protect the environment as intended and that the Contractor complies with all relevant legislation and the conditions of any environmental consents which is required to obtain. The ESMoP shall have the content and format specified in Attachment 3 [Contractor's Environmental and Social Monitoring Plan] to Clause 16 [SHE Requirements] of Specifications.

2.2.4 As to accident prevention, the following plans shall be supplemented to the SHE Plan.

- (1) Safety and Health Plan (SHP): The Contractor shall prepare a SHP to effectively implement the preventive measures taking into account envisaged conditions, situations and particular activities of the Works which may induce accidents. Then the Contractor shall plan measures to be implemented in all Work Areas in various construction stages. The Contractor is responsible for incorporating the accident prevention measures against anticipated dangerous occurrences into the SHE activities to enable to efficiently carry out the measures in a practical manner. The SHP shall have the content specified in Attachment 4 [Contractor's Safety and Health Plan] to Clause 16 [SHE Requirements] of Specifications. Submission procedure shall be the same as that of the ESMP.
- (2) Safety and Health Monitoring Plan (SHMoP): The Contractor shall prepare a SHMoP setting out in detail non-compliance with the relevant clauses and paragraphs hereinafter relevant to the SHE management.

## **2.3 INSPECTION AND AUDIT**

2.3.1 The Contractor shall audit all of the activities described in his ESMP and ESMoP and SP&P and SMoP at monthly intervals (as part of Monthly SHE Audit) or as otherwise required by the Engineer and shall keep appropriate records of this activity.

## **2.4 ORGANIZATION**

- 2.4.1 The Contractor shall provide and maintain an organizational structure which is comprised of a team referred to as the Environmental Team being in charge of the environmental and social protection and a team referred to as the Safety and Health Team being in charge of the accident prevention and health promotion to effectively implement activities to fulfil the obligations as described hereinbefore.
- 2.4.2 The Contractor shall within 42 days after the Commencement Date nominate a fully qualified and experienced SHE Director as having overall responsibility for SHE management. The SHE Director is responsible for directing and coordinating multiple disciplines in the Contractor's organization including the Environmental Team and the Safety and Health Team as being in the SHE organization. The Contractor shall ensure that the Contractor's representatives shall be responsible and directly accountable to the SHE Director in all the concerned matters. The Contractor shall appoint SHE management officers and personnel in his Environmental Team and his Safety and Health Team. These appointments shall be subject to a statement of "no objection" by the Engineer.
- 2.4.3 Within 42 days after the Commencement Date, the Contractor shall appoint a suitably qualified and experienced full time Chief Environmental Officer (CEO) who will be responsible for day-to-day environmental and social management, supervision and monitoring in and outside the Work Area and for implementing all aspects of the Contractor's ESMP and ESMoP. The CEO will have authority to stop construction works if environmental non-compliance is observed. The Contractor shall also appoint at least one Senior Environment Officer (SEO) at each site, who has delegated responsibility for environmental and social management on each shift at that site. The SEO shall be assisted by Environment Officers (EO) working under his direction as necessary. Environmental affairs include social issues and the ESMP shall also identify a Community Liaison Officer (CLO) who will deal with community relations and liaise on behalf of the Contractor with people who may be affected by the construction process.
- 2.4.4 Within 42 days after the Commencement Date the Contractor shall also appoint a full time Chief Accident Prevention Officer (CAPO) who will be in charge of all matters concerning health and safety in relation to the Works. The CAPO shall be suitably qualified and experienced. His minimum qualifications shall be as per provisions contained in Building and Other Construction Workers' (Regulation of Employment and Conditions of Service) Central Rules, 1998. The CAPO shall be authorized to initiate accident prevention measures and monitor the workplace conditions in these respects. The Contractor shall also appoint at least one Senior Accident Prevention Officer (SAPO) at each site, who has delegated responsibility for the maintenance of safety and health on each shift at that site. The SAPO shall be assisted by Safety and Health Officers (SHO) working under his direction as necessary.
- 2.4.5 In addition to the aforementioned location-based staffing, the Contractor shall provide the following function-based staffing, including but not limited to:
- Occupational Health Officer(s) with Nursing Assistants for administration and operation of the Occupational Health Centre (First Aid Station);
  - Senior Traffic Engineer(s) for establishing the Traffic Management Plan and implementing/ monitoring the Plan;
  - Senior SHE (Electrical) Engineer(s) for conducting monthly Electrical Safety Audit
  - House Keeping and Site Maintenance Squads for operating and maintaining the Temporary Facilities for the Contractor's use and for the Employer's and the

Engineer's use.

- Labour Welfare Officer(s) with supporting staff for overall general administration for SHE management.

2.4.6 The Contractor shall not remove the appointed the aforementioned officers without the prior written consent of the Engineer and any replacement shall be nominated by the Contractor at the same time that the consent is sought.

## **2.5 CONDITIONS OF PROVISIONS**

2.5.1 The provisions listed herein regarding environmental and social protection and safety and health promotion shall apply to and be binding upon the Contractor, his employees and any sub-contractors and their employees, for any activities related to the construction works whether in and outside the Work Area. The Contractor shall ensure that proper and adequate provisions to this end are included in all sub-contracts placed by him.

2.5.2 These provisions may be overridden in the event of an extreme emergency, where works or actions are necessary in order to save life or property, or to maintain the safety of the Works.

2.5.3 The Contractor shall also routinely observe and monitor the environmental and social impacts of the ongoing construction activities and safety and health conditions of all his employees and of the general public whilst exposed to construction activities whether on or off-site. The Contractor shall take any further action as may be deemed necessary by the Engineer to mitigate and/or to prevent any additional unexpected impacts and/or results that may occur.

2.5.4 The Engineer will inspect the Contractor's environmental and social and safety and health performances in the course of his normal supervision activities and the Contractor will cooperate by providing access to the Work Area and such sites, equipment, staff, records, etc. as may be requested by the Engineer either in writing or verbally.



## **PART II SHE MANAGEMENT**

### **3 GENERAL**

#### **3.1 Scope**

3.1.1 This document defines the principal requirements of the Employer on SHE associated with the Contactor / sub-contractor and any other agency to be practiced at construction worksites at all time.

#### **3.2 Definition / Languages**

3.2.1 In this document:

- i) BOCWA means Building and Other Construction Workers (Regulation of Employment and Conditions of Service) Act, 1996
- ii) BOCWR means Building and Other Construction Workers (Regulation of Employment and Conditions of Service) Central Rules, 1998

#### **3.3 Application of This Document**

3.3.1 This document applies to all aspects of the Contactor's scope of work, including all aspects conducted by sub-contractors and all other agencies. There shall be no activity associated to the contract, which is exempted from the purview of this document.

#### **3.4 Purpose of This Document**

3.4.1 The objective of this document is to ensure that adequate precautions are taken to avoid accidents, occupational illness and harmful effects on the environment during construction.

3.4.2 This document:

- i) Describes SHE interfaces between the Employer/Engineer and the Contractor.
- ii) Details the processes by which the Contactor shall manage SHE issues while carrying out the works under the Contract.

3.4.3 These requirements shall be read together with OHSAS 18001-1999, Occupational Health and Safety Management System and ISO 14001: 2004 Environmental Management Systems.

#### **3.5 'SHE' Targets and Goals**

- i) The SHE targets, goals and aim for the Works are to achieve:
- ii) Zero total recordable injuries
- iii) Zero reportable environmental incidents
- iv) Induction of all personnel in accordance with the approved Contactor's SHE Plan
- v) Total compliance of conducting inspections and audits as per approved SHE Plan
- vi) 100% incident recording and reporting

- vii) 100% adherence of usage of appropriate personal protective equipment (PPEs) at work.
- viii) Executing construction work with least disturbance to the environment, adjoining road users and traffic.

## **4 COMPLIANCE**

### **4.1 Employer's Policy on Labour Protection**

- 4.1.1 The Contractor shall implement the Employer's Policy on Labour Protection for carrying out all the construction works under this contract whether directly or through a sub-contractor or through any other agency. A copy of the Policy is attached as Attachment 5 [Workplace Policy on Labour Protection] to Clause 16 [SHE Requirements] of Specifications.

### **4.2 Indian Statutory Requirements**

- 4.2.1 The Contractor shall develop a thorough understanding of BOCWA and BOCWR, not only to satisfy the Inspectors' perspective but the use of legislation as the strong tool for effective SHE management at construction worksites. The Contractor is strongly advised to practice the principle of voluntary compliance.
- 4.2.2 In order to facilitate the Contractor for better understanding on the various provisions of the above Act and Rules, a tabulated information highlighting the sections/rules referring to the corresponding registration of contractors, maintenance of registers and records, hours of work and wages, welfare, medical facilities and safety requirements are given in Attachment 6 [Safety, Welfare and Occupational Health Requirements as per BOCW Act 1996] to Clause 16 [SHE Requirements] of Specifications. It is an indicative one and not a limiting list.
- 4.2.3 The construction works shall be undertaken in accordance with all applicable legislation and Indian statutory requirements listed below but not limiting to:
  - (1) Indian Electricity Act 2003 and Rules 1956
  - (2) National Building Code, 2005
  - (3) Factories Act, 1948 and concerned State Govt Factories Rules.
  - (4) Motor Vehicles Act as amended in 1994, The Central Motor Vehicles Rules, 1989 and Motor Vehicle Rules of the concerned State Government as amended from time to time
  - (5) Indian Road Congress Code IRC: SP: 55-2001 'Guidelines on Safety In Road Construction Zones.
  - (6) The Petroleum Act, 1934 and Rules 1976
  - (7) Gas Cylinder Rules, 2003
  - (8) Indian Explosives Act. 1884, along with the Explosives substance Act 1908 and the Explosives Rules 1983
  - (9) The (Indian) Boilers Act, 1923
  - (10) The Public Liability Insurance Act 1991 and Rules 1991
  - (11) Minimum Wages Act, 1948 and Rules 1950

- (12) Contract Labour (Regulation and Abolition) Act, 1970 and Rules 1971
- (13) Child Labour (Prohibitions & Regulations) Act, 1986 and Rules 1950
- (14) Environment Protection Act, 1986 and Rules 1986
- (15) Indian Wildlife (Protection) Act 1972 and its subsequent amendments
- (16) Forest (conservation) Act 1980 and rules thereunder
- (17) Air (Prevention and control of Pollution) Act, 1981
- (18) Water (Prevention and Control of Pollution) Act, 1974
- (19) The Noise Pollution (Regulation & Control) Rules, 2000
- (20) Notification on Control of Noise from Diesel Generator (DG) sets, 2002
- (21) Recycled Plastics Manufacture and Usage Rules 1999
- (22) Ground Water (Regulation, Development and Management) Rules 2007
- (23) Manufacture, Storage & Import of Hazardous Chemicals Rules, 1989
- (24) The Hazardous Wastes (Management, Handling and Trans-boundary Movement) Rules 2008 and its amendment
- (25) Chemical Accidents (Emergency Planning, Preparedness and Response) Rules 1996
- (26) Batteries (Management and Handling) Rules
- (27) Fly ash utilization notification, September 1999 as amended in August 2003
- (28) Payment of Wages Act, 1936;
- (29) Equal Remuneration Act, 1976;
- (30) Employees Provident Fund and Miscellaneous
- (31) Provisions Act, 1952;
- (32) Payment of Gratuity Act, 1972;
- (33) Employees State Insurance Act, 1948;
- (34) Payment Of Bonus Act, 1965;
- (35) Maternity Benefit Act, 1951;
- (36) Industrial Disputes Act, 1947;
- (37) Industrial Employment (Standing Orders) Act, 1946;
- (38) Trade Unions Act, 1926;
- (39) Building and Other Construction Workers (Regulation of Employment of Service) Act of 1996;

- (40) Inter State Migrant Workmen's (Regulation of Employment and Conditions of Service ) Act ,1979;
- (41) Workmen Compensation Act. 1923;
- (42) Mines Act, 1952.

4.2.4 Notwithstanding the above Act/Rules, there is nothing in those to exempt the Contractor from the purview of any other Act or Rule in Republic of India for the safety of men and materials.

4.2.5 If the requirements stated in this document are in conflict or inconsistent with the requirements of applicable laws, the more stringent requirements shall apply.

#### **4.3 International Standards, Guidelines & ISO Certifications**

4.3.1 The works should be undertaken in accordance with the applicable international guidelines, standards and specifications on SHE and the Contractor shall be accredited under the following schemes:

- a) OHSAS 18001-2007:Occupational Health and Safety Management System
- b) ISO 14001-2004:Environmental Management Systems

4.3.2 The process of certification shall start immediately after the award of the work and complete within reasonable minimum time. Towards this, the Contractor shall undertake the required steps including appointment of ISO consultant suggested in the General Instruction DFCCIL/SHE/GI/010 in Attachment 9 [Reference for SHE Activities] to Clause 16 [SHE Requirements] of Specifications for obtaining the certification on Occupational Health and Safety Management System and Environment Management System.

4.3.3 The Contactor is free to choose any ISO consultant of his choice other than the listed ISO consultants, however he shall demonstrate the competency of the consultant and obtain the Engineer/ Employer's approval.

4.3.4 In case of contractors along with the joint venture partners, who possess a valid certification of either ISO 14001 or OHSAS 18001 or both shall include DFCCIL contract in their immediate following surveillance audit which normally takes place at the interval stipulated in those practices. The required documentation shall be undertaken with the help of the ISO consultant. If the same can be done in-house the same shall be demonstrated to the Engineer/ Employer. If any of the joint venture partners do not possess the ISO 14001 or OHSAS 18001 certification then the Contractor shall obtain a fresh certification.

4.3.5 In case of failure on the part of the Contractor, the Engineer/ Employer at the cost of the Contactor shall do the same.

#### **4.4 Contractor's Statutory Obligations**

4.4.1 The obligations and requirements for SHE under this Contract are entirely without prejudice to and do not release the Contractor from his statutory obligations with respect to safety, environment and industrial health.

### **5 CONTRACTOR SHE POLICY AND PLAN**

5.1.1 The Contractor shall prepare, submit, amend and improve his SHE Policy and SHE

Plan and get it approved as detailed in Clause 16 (2.2).

5.1.2 The SHE Plan shall include the following but not be restricted to:

- i) A statement of the Contractor's SHE Policy as per Section 39 of BOCWR and bringing out the intent, organisation and arrangements for making SHE Policy and Plan effective
- ii) The name(s) and experience of person(s) within the Contractor's proposed management who shall be responsible for co-ordinating and monitoring the Contractor's SHE performance;
- iii) The number of SHE staff who shall be employed on the Works, their responsibilities, authority and line of communication with the proposed Contractor's agent;
- iv) A statement of the Contractor's policy and procedures for identifying and estimating hazards and the measures for addressing the same;
- v) A list of SHE hazards anticipated for this Contract and sufficient information to demonstrate the Contractor's proposals for achieving effective and efficient health and safety procedures;
- vi) A statement on Contractor's approach / policy on sub-standard and unsafe engineering & construction practices and their control
- vii) A SHE checklist indicating various aspects to be ensured before taking up different activities
- viii) Arrangement of training of workers, supervisors and other staff along with a description of the SHE training courses and emergency drills which shall be provided by the Contractor, with an outline of the syllabus to be followed;
- ix) Details of the safety equipment which shall be provided by the Contractor, including personal protective equipment (PPE);
- x) A statement of the Contractor's policy and procedures for ensuring that Contractor's Equipment used on the project Site are maintained in a safe condition and are operated in a safe manner;
- xi) A statement of the Contractor's policy and procedures for ensuring that sub-contractors comply with the Contractor's safety plan;
- xii) A statement of the Contractor's disciplinary procedures with respect to SHE related matters;
- xiii) A statement of the Contractor's procedure for reporting and investigating accidents, dangerous occurrences or occupational illnesses;
- xiv) A statement of the Contractor's arrangements for appointment of a SHE Committee, especially in compliance with Clause 39 of BOCWR;
- xv) A statement of the Contractor's arrangements to provide for welfare facilities for his employees including implementation of Employer's Policy on HIV/AIDS Prevention and Control for Workers engaged by Contractors;

- xvi) A statement of the Contractor's arrangements to implement Employer's Policy on Labour Protection;
  - xvii) Mockup Drills
  - xviii) Contractor's Emergency Response Plan.
- 5.1.3 The Contractor shall, from time to time and as necessary, is required by the Engineer to produce supplements to the SHE Plan such that it is at all times a detailed, comprehensive and contemporaneous statement by the Contractor of his site safety, industrial health and environment obligations, responsibilities, policies and procedures relating to work on a site. Any and all submissions of supplements to the SHE Plan shall be made to the Engineer in accordance with the agreed procedures.
- 5.1.4 If at any time during the course of execution of the Work, the SHE Plan in the Engineer's opinion, is insufficient or requires revision or modification to ensure the security of the Works and the safety of all workmen/ visitors in the Work Area, the Engineer may instruct the Contractor to revise the SHE Plan and the Contractor shall within 21 days submit the revised plan(s) to the Engineer for review.
- 5.1.5 Any omissions, inconsistencies and errors in the SHE Plan or the Engineer's acceptance or rejection of the SHE Plan and/or supplements thereto shall be without prejudice to the Contractor's obligations with respect to site safety, industrial health and environment and shall not be an excuse for any failure by the Contractor to adopt proper and recognised safety practices throughout the execution of the Work and also shall not be a reason for extension of completion time of the project.
- 5.1.6 The Contractor shall adhere to the SHE Plan and shall ensure that all sub-contractors of all tiers require that contracting parties each have a copy of the relevant Site SHE Plan and comply with its provisions.
- 5.1.7 The details of contents to be covered in the SHE plan are given in Attachment 1 [Content of Contractor's SHE Plan] to Clause 16 [SHE Requirements] of Specifications.
- 5.1.8 The Contractor shall also submit a detailed SHE Plan, specific to each site, called hereinafter as the Site SHE Plan, for consent of the Engineer which shall include the requirements of the safety from Clause 16 (26 to 51) as given hereinafter.
- 5.1.9 The Contractor shall provide all necessary access, assistance and facilities to enable the Engineer to carry out surveillance to verify that the Site SHE Plan is being properly and fully implemented.

## **6 ROLE OF DESIGN TEAM IN CONTRACTOR'S ORGANIZATION**

### **6.1 Role of Design Team in Safety, Health and Environment**

- 6.1.1 In this design-build Contract, the Contractor has a design Team in his project organization and the Design Team's primary role includes to minimise the risk to health and safety of those who are going to construct, maintain, clean, repair, dismantle or demolish the structures and others like adjoining road users/general public, who might be affected by the work.

### **6.2 General Philosophy**

- 6.2.1 When considering health and safety in the Design Team's work, they shall be expected to do what is reasonable at the time the design is prepared. It may be possible for hazards, which cannot be addressed at the feasibility stage to be looked at during

detailed design. In deciding what is reasonably practicable, the risk to health and safety produced by a feature of the design has to be weighed against the cost of excluding the feature. The overall design process does not need to be dominated by a concern to avoid all risks during the construction phase and maintenance. However, a judgment has to be made by weighing up one consideration against another so the cost is counted not just in financial terms, but also those of fitness for purpose, aesthetics, build ability or environmental impact. By applying these principles, it may be possible to make decisions at the design stage, which will avoid or reduce risks during construction work. In many cases, the large number of design considerations will allow a number of equally valid design solutions. What is important is the approach to the solutions of design problems. This should involve a proper exercise of judgement, which takes account of health and safety issues.

### **6.3 Hierarchy of Risk Control**

6.3.1 The Design Team shall need, so far as reasonably practicable, to avoid or reduce risks by applying a series of steps known as the hierarchy of risk control or principles of prevention and protection. The steps to be adopted shall include but not limited to the following:

- i) consider if the hazard can be prevented from arising so that the risk can be avoided (e.g., alter the design to avoid the risk);
- ii) if this cannot be achieved, the risk should be combated at source (e.g., ensure the design details of items to be lifted include attachment points for lifting);
- iii) failing this, priority should be given to measures to control the risk that will protect all people;
- iv) only as a last resort should measures to control risk by means of personal protection be assumed (e.g., use of safety harnesses).

### **6.4 Duty to Provide Health and Safety Risks in the Drawing itself**

6.4.1 In case of situations where the Design Team has carried out the design work and concluded that there are risks, which were not reasonably practicable to avoid, detailed information shall be given about the health and safety risks, which remain. This information needs to be included with the design to alert others to the risks, which they cannot reasonably be expected to know. This is essential for the parties who have to use the design information.

6.4.2 If the Design Team's basic design assumptions affect health or safety, or health and safety risks are not obvious from the standard design document, the Design Team shall provide additional information. The information shall include a broad indication of the assumptions about the precautions for dealing with the risks. The information will need to be conveyed in a clear manner; it shall be included on drawings, in written specifications or outline method statements. The level of detail to be recorded will be determined by the nature of the hazards involved and the associated level of risk.

### **6.5 Engineer's Consent**

6.5.1 Every structure like scaffold, false work, launching girder, earth retaining structures etc. shall have its design calculations included in the method statements in addition to health and safety risks. The Engineer shall examine and communicate his consent as per the contract conditions.

- 6.5.2 Any non-standard structures like trestles made up of re-bars or structures which are very old, corroded, repaired for many times etc. for which no design calculations can be made accurately from any national standards, shall not be allowed to be used at sites even for short duration.

## **7 CONTRACTOR'S SHE ORGANISATION**

### **7.1 Education and Experience**

- 7.1.1 The Contactor shall appoint adequate numbers of the required SHE personnel keeping in view the General Instruction DFCCIL/SHE/GI/001 as indicated in Attachment 9 [Reference for SHE Activities] to Clause 16 [SHE Requirements] of Specifications for reference and based upon the statutory requirement and establish the SHE organisation appropriate to the size and complexity of the project. The minimum educational qualification and the work experience are also given in the General Instruction DFCCIL/SHE/GI/002 as indicated in Attachment 9 [Reference for SHE Activities] to Clause 16 [SHE Requirements] of Specifications.

- 7.1.2 In order to effectively implement the requirements herein and to interact on safety and labour welfare matters with and the statutory authorities enforcing the safety and labour welfare legislations as well as the Engineer, the Contractor shall employ adequate numbers of full time Labour Welfare Officer duly qualified and experienced as per Clause 16 (2.6.1.1).

### **7.2 Conduct and Competency**

- 7.2.1 The conduct and functioning of the Contractor SHE personnel shall be monitored by the Engineer. Any default or deficiency shall attract penalty as per details given under penalty clause of this document.

### **7.3 Engineer's Consent**

- 7.3.1 The name, address, educational qualification, work experience and health condition of each personnel deployed for SHE jobs shall be submitted to the Engineer in the format prescribed for the purpose for comments and obtaining his consent well before the start of the work. Only on receipt of consent by the Engineer, these personnel are authorised to work. In case any of the SHE personnel leaves the Contactor the same shall be intimated to the Engineer immediately. The Contactor shall also employ the new personnel as per the aforesaid procedure.

### **7.4 Responsibility of SHE Personnel**

- 7.4.1 For all works carried out by the Contractor and his sub-contractors, the responsibility of ensuring the required SHE manpower lies with the main Contractor only. The minimum required manpower indicated by the Employer shall include the sub-contractors' workers also. It shall be the responsibility of the Contractor to provide required SHE manpower for all the works executed by all his sub-contractors. Necessary conditions shall be included in all sub-contract documents executed by the Contractor.

### **7.5 Employment Status of SHE Personnel**

- 7.5.1 No contractor shall engage SHE manpower from any outsourcing agencies in which case the effectiveness would be lost. All SHE manpower shall be on the payroll of the main Contractor only and not on the payroll of any sub-contractor or outsourcing manpower agencies, etc. This condition does not apply to positions like traffic marshals



who are engaged almost on a daily requirement basis.

## **7.6 Reporting of SHE Personnel**

7.6.1 All SHE personnel in the Environmental Team shall report to the Chief Environmental Officer and all SHE personnel in the Health and Safety Team shall report to the Chief Accident Prevention Officer. These Chief Environmental and Chief Accident Prevention Officers shall report directly to the Contractor's Representative and the Engineer. The Engineer shall monitor adherence to this procedure at all times.

## **7.7 Inadequate SHE Personnel**

7.7.1 In case the Contractor fails to provide the minimum required manpower, or fail to fill up vacancies created within 14 days, the same shall be provided by the Engineer at the Contractor's cost. Any administrative expenses involved to provide the same, like, paper advertisement or manpower consultant charges, etc., shall also be at the cost of the Contractor.

## **7.8 Prohibition of Performance of Other Duties**

7.8.1 No SHE personnel shall be required or permitted to do any work which is unconnected to, inconsistent with or detrimental to the performance of the SHE duties which were stipulated in the SHE Plan and other detailed plans that defined SHE activities as have been submitted to and consented by the Engineer.

## **7.9 Facilities to be Provided to SHE Personnel**

7.9.1 The Contractor shall provide all SHE personnel with such facilities, equipment and information that are necessary to enable him to dispatch his duties effectively.

7.9.2 The minimum Employer's Requirements of such facilities / equipment to be provided for SHE personnel are indicated in the General Instruction DFCCIL/SHE/GI/003 in the Attachment9[Reference for SHE Activities] to Clause 16 [SHE Requirements] of Specifications.

# **8 CONTRACTOR'S SHE COMMITTEE**

## **8.1 General**

8.1.1 The Contractor shall form and maintain a committee referred to as the SHE Committee/Site SHE Committee being comprised of the Contractor's Personnel as defined and described in the clauses hereinafter.

## **8.2 Terms of Reference**

8.2.1 The Terms of Reference for the SHE Committee shall be as follows;

- i) To establish company safety policies and practices
- ii) To monitor the adequacy of the Contractor's SHE plan and ensure its implementation
- iii) To review SHE training
- iv) To review the Contractor's monthly SHE reports.
- v) To identify probable causes of accident and unsafe practices in building or other construction work and to suggest remedial measures.

- vi) To stimulate interest of Employer and building workers in safety by organizing safety week, safety competition, talks and film-shows on safety, preparing posters or taking similar other measures as and when required or as necessary.
- vii) To go round the construction site with a view to check unsafe practices and detect unsafe conditions and to recommend remedial measures for their rectifications including first-aid medical and welfare facilities.
- viii) Committee team members should perform a site inspection before every committee meetings and to monitor SHE inspection reports.
- ix) To bring to the notice of the Engineer the hazards associated with use, handling and maintenance of the equipment used during the course of building and other construction work.
- x) To suggest measures for improving welfare amenities in the construction site and other miscellaneous aspect of safety, health and welfare in building or other construction work.
- xi) To look into the health hazards associated with handling different types of explosives, chemicals and other construction materials and to suggest remedial measures including personal protective equipment.
- xii) To take punitive action against erring Contractor's agents / engineers at Site who do not heed to the advise on SHE aspects
- xiii) To review the last safety committee meeting minutes and to take action against persons/sub-contractors for non-compliance if any.

8.2.2 Within 14 days of the Commencement Date, the SHE Committee shall be constituted and notification regarding the same shall be communicated to the members and employees as per the format provided in Form No.:SF 001 as attached in the Attachment 9 [Reference for SHE Activities] to Clause 16 [SHE Requirements] of Specifications.

8.2.3 The SHE Committee meetings shall be conducted at least once in a month with the minimum members listed below:

Chairman	Contractor's Representative
Secretary	SHE Director
Members	i) Chief Environmental Officer ii) Chief Accident Prevention Officer iii) Labour Welfare Officer iv) Senior Managers/ Engineers heading different functions v) Sub – contractor's representative vi) Workers' representative
Employer's Representatives	i) The Engineer ii) DFCCIL SHE in charge and other representatives

8.2.4 The Site SHE Committee meetings shall be conducted at least once in a week with the minimum members listed below:

Chairman	Contractor’s Representative at the site
Secretary	Senior Environmental Officer Senior Accident Prevention Officer
Employer’s Representatives	Engineer’s representative at the Site
Members	Sub- Contractor’s representative Workers’ representatives SHE staff

**8.3 Other Contractors’ Participation**

- 8.3.1 In case of depot, station and other contiguous areas where more than one main contractors are working together, the Engineer shall instruct the other contractors to join for the monthly SHE committee meeting of the Contractor, so as to discuss and decide about the common provision of security, lighting, toilet, drinking water etc. and sharing the maintenance cost of the same etc.
- 8.3.2 The general principle for sharing the cost shall be based on the contract value of works executed at the contiguous area, the daily average number of workmen employed by each contractor in the contiguous area, or other pertinent criteria if applicable and mutually agreed upon. In case of any disagreement, the Engineer’s decision shall be final & binding

**8.4 Minimum Time between Two Monthly SHE Committee Meetings**

- 8.4.1 A minimum period of 21 days shall be maintained between any two SHE monthly committee meetings.

**8.5 Agenda**

- 8.5.1 The Secretary shall circulate the agenda of the meeting at least three (3) working days in advance of the scheduled date of the meeting to all members.
- 8.5.2 The agenda should broadly cover the following:
  - i) Confirmation of minutes
  - ii) Chairman’s review/overview of site SHE performance / condition
  - iii) Previous month SHE statistics
  - iv) Incident and Accident Investigation / dangerous occurrence / near miss report
  - v) Site SHE inspection
  - vi) Sub-contractors’ SHE issues
  - vii) Safety presentation by Members
  - viii) Report from the Engineer
  - ix) Matters arising

- x) Any other business

## **8.6 Minutes of the Meeting**

- 8.6.1 The minutes of the meeting shall be prepared as per the format provided at Form SF-002 in Attachment 9 [Reference for SHE Activities] to Clause 16 [SHE Requirements] of Specifications and sent to all members within 2 working days preferably by mail/fax followed by hardcopy. Safety Committee meeting minutes shall also be displayed in the notice board for wider publicity to all concerned.

## **8.7 Disciplinary Action**

- 8.7.1 The chairman shall inform the members of any outstanding issues in the meeting and in case of repeated offence/non-compliance by some members or other co/sub-contractors and propose suitable disciplinary action including provisions of monetary penalty as per the relevant contract clauses, the Engineer shall ensure that the same is implemented.

## **9 ID CARD AND FIRST DAY AT WORK, SHE ORIENTATION TRAINING**

- 9.1.1 The Contractor shall ensure that all personnel working at the site receive an induction SHE training explaining the nature of the work, the hazards that may be encountered during the site work and the particular hazards attached to their own function within the operation. The training shall cover the contents as suggested in the General Instruction DFCCIL/SHE/GI/004 in Attachment 9 [Reference for SHE Activities] to Clause 16 [SHE Requirements] of Specifications.
- 9.1.2 All Contractor's Personnel shall be issued a photo identity card of size 85mm x 55mm duly signed by the authorized representative of the Contractor before they are engaged for any work as per the format indicated in the General Instruction DFCCIL/SHE/GI/005 in Attachment 9 [Reference for SHE Activities] to Clause 16 [SHE Requirements] of Specifications.
- 9.1.3 The Contractor shall also issue a personnel SHE handbook in a language known to the workers, which provides information on SHE and emergency procedures that all personnel involved in the Work are required to know and the need to follow. The Contractor shall ensure that this is distributed and its content introduced to all personnel working in the Work Area.

## **10 SHE TRAINING**

- 10.1.1 The behaviour of people at all levels of the Contractors is critical for SHE performance.
- 10.1.2 The Contractor shall organise quality SHE training to engage Managers, supervisors and other personnel in behavioural change and improve safety performance.
- 10.1.3 The Contractor shall analyse the training requirements for all the employees and initiate a training program to demonstrate that all persons employed, including subcontractors, are suitably qualified, competent and fit. This will include:
  - i) Detailed Job descriptions for all personnel, to include their specific SHE responsibilities
  - ii) Specification of qualifications, competency and training requirements for all personnel

- iii) Assessment and recording of training needs for all personnel, including subcontractors' employees in the workforce, vendor representatives and site visitors
  - iv) A system for assessing new hirers e.g. previous training
  - v) A means of confirming that the system is effective
  - vi) A matrix and schedule of training requirements, covering general, task-specific and SHE-related training, showing the training frequency and interval between refresher courses
  - vii) Timely, competent delivery of training courses
- 10.1.4 The Contractor shall arrange behavioural-based training programmes for all the executives to identify, recognise and eliminate unsafe act and unsafe conditions.
- 10.1.5 The minimum Employer's requirements of training needs for various categories of employees are suggested in General Instruction DFCCIL/SHE/GI/006 in Attachment 9 [Reference for SHE Activities] to Clause 16 [SHE Requirements] of Specifications.
- 10.1.6 The contents of SHE training to Managers/Supervisors as given in General Instruction DFCCIL/SHE/GI/007 in Attachment 9 [Reference for SHE Activities] to Clause 16 [SHE Requirements] of Specifications shall be conducted.
- 10.1.7 The refresher-training programme to all employees shall be conducted once in six months.
- 10.1.8 On-job training by way of toolbox talk shall be conducted to all high-risk workmen everyday.
- 10.1.9 On-the spot practical skill development training on height safety including scaffold & formwork safety, crane safety, welding safety, electrical safety, work adjacent to tracks/ roads and traffic safety for marshals, shall also be conducted to all foremen/ workmen who were associated to the concerned jobs.
- 10.1.10 Daily Safety Oath shall be taken by every employee including workman.
- 10.1.11 All vehicle drivers including hydra operators shall be trained on defensive driving at Automobile Association of Western India or other organisation identified by the Employer. All vehicle drivers shall also undergo refresher training on defensive driving provided by the same institute once in 6 months.
- 10.1.12 All the above listed training programmes except at Clause 16 (2.9.11) shall be organised by the Contractor only after taking approval from the Engineer for the training faculty / organisation, content and durations. Some of the agencies are listed in DFCCIL/SHE/GI/010 in Attachment 9 [Reference for SHE Activities] to Clause 16 [SHE Requirements] of Specifications, which may be referred.
- 10.1.13 In case of failure on the part of the Contractor to provide all the above-mentioned training programs to all employees in time, the same shall be provided by the Employer through accredited agencies if required by formulating a common scheme to all contractors. It is mandatory for the Contractors to participate in the common scheme. Any administrative expenses and training fee towards the same shall be at the cost of the Contractor.
- 10.1.14 Mock up drills shall be carried out at a pre-defined intervals and the analyses report submitted to SHE Committee.

## **11 SHE INSPECTION**

### **11.1 General**

11.1.1 The Contractor shall evolve and administer a system of conducting SHE inspections and other risk management analysis on a periodical basis.

11.1.2 The purpose of SHE inspection is to identify any variation in construction activities and operations, machineries, plant and equipment and processes against the SHE Plan and its supplementary procedures and programs.

11.1.3 Following SHE inspections program shall be adopted.

- i) Planned General Inspection
- ii) Routine Inspection
- iii) Specific Inspection
- iv) Other Inspection

### **11.2 Planned General Inspection**

11.2.1 Planned General Inspections are performed at predetermined intervals and it usually involves the representation from both Contractor and the Employer/ Engineer.

11.2.2 Inspections that will be classified under this inspection program are:

- i) Monthly Contractor and subcontractor's site safety committee Inspection.
- ii) Weekly safety inspection by construction supervisors (Contractors and Sub-contractors).
- iii) Daily safety inspection by the SHE teams (Health and Safety Team and Environmental Team).

### **11.3 Routine Inspection**

11.3.1 Routine Inspections are often referring to the inspection of Work Area, equipment and temporary structures performed by site and equipment operators and temporary structure erectors.

11.3.2 Inspections that will be classified under this inspection program are:

- i) Daily Inspection of plant and equipment by operator
- ii) Weekly Inspection of scaffold by scaffolding supervisor
- iii) Monthly Inspection of electrical hand tools by competent electrical supervisor
- iv) Quarterly Inspection of temporary electrical and mechanical systems by competent supervisor
- v) Half-yearly inspection of lifting machinery, lifting appliances, equipment and gears by Govt. approved competent person.

11.3.3 The list mentioned above is not exhaustive. Contractor may add additional categories.

Contractors' site SHE Officers and Managers will ensure that a system of routine inspections are carried out periodically to all plants, equipment, powered tools and any other temporary structures that will pose a hazard to operators and workmen.

#### **11.4 Specific Inspection**

11.4.1 Specific Inspections are performed on activities without a predetermined date. Competent supervisors usually perform inspections for ensuring an activity whether it is executed in accordance to a general set of rules; method statement submitted or developed procedures.

11.4.2 The following are examples that will be commonly performed as required on the construction site:

- i) Inspection performed before a heavy lifting operation.
- ii) Inspection performed before and after the entry of person into a confined space.
- iii) Inspection performed before and after a welding and gas cutting operation.
- iv) Inspection of formwork before concreting by formwork erector.
- v) Inspection of temporary earth support systems before and after excavation

11.4.3 The list mentioned above is not exhaustive. The Contractor shall ensure that a competent supervisor inspects all high-risk processes and activities.

#### **11.5 Other Inspection**

11.5.1 Other inspections includes the following:

- i) Mandatory Inspections by Labour Department of Government
- ii) Employer's site SHE management team
- iii) Air and noise Quality Monitoring and Inspection

11.5.2 The Contractor shall prepare all required safety inspection checklist for all activity operations and equipment. Checklists will be prepared based on the Indian standards, rules and regulations and Employer's Requirements.

11.5.3 All inspection records and reports will be properly kept and filed for audit purpose. Inspection reports of Planned General Inspection and Routine Inspection shall be used for discussion at SHE Committee Meetings.

11.5.4 The Engineer reserves the right to order the immediate removal and replacement of any item of Contractor's Equipment or Temporary Works which, in his opinion, is unsatisfactory for its purpose or is in an unsafe condition.

## **12 SHE AUDIT**

### **12.1 General**

- 12.1.1 The purpose and scope of SHE audit is to assess potential risk, liabilities and the degree of compliance of the SHE Plan and its supplementary procedures and programs against applicable and current SHE legislation regulations and requirements of the Employer.
- 12.1.2 The Contractor’s Representative holds the ultimate responsibility in ensuring implementation of SHE audit program during the construction work.

**12.2 Monthly Audit Rating Score (MARS)**

- 12.2.1 Monthly Audits will be conducted in accordance with DFCCIL guidelines. The Contractor’s senior manager and SHE in-charge should also be invited to attend.
- 12.2.2 Monthly Audit Rating Score (MARS) will be performed once in a month. A team consisting of Contractor’s Representative and the Engineer based on the pre-designed score-rating format will conduct it.
- 12.2.3 The MARS report will enable the Engineer to evaluate the general compliance by the Contractor with the Conditions of Contract and the Contractor’s Site SHE Plan.
- 12.2.4 The MARS should be conducted at least 7 days prior to the scheduled date of Monthly SHE Committee meeting.
- 12.2.5 The numerical scoring has been weighed on a 1-10 scale. The audit team will use their observations noted in evaluating the points to be awarded against each of the elements of the audited section. Wherever some topics and sub-topics are not applicable the score rating need not be given. The overall audit ratings shall be achieved by:

Overall Audit rating =  $\frac{\text{Actual Score Achieved}}{\text{Maximum Possible Score}} \times 100$

Maximum Possible Score

- 12.2.6 The criticality of the required actions for the respective sections of the Audit will be classified as :

Sl. No.	Score	Description	Action
1	< 60%	Immediate	Require Contractor to rectify within 24 hours
2	< 75%	Improvement Necessary	Contractor rectification within 7 days and confirmed in writing to the Engineer
3	< 90%	Improvement Desirable	Contractor rectification within one month and confirmed in writing to the Engineer

- 12.2.7 A copy of each Audit Report will be sent to the Engineer, the Employer and to all subcontractors, with whom it will then be discussed in detail at the Monthly SHE Committee Meeting in order to ensure that any corrective actions are agreed upon.

**12.3 Monthly Electrical Safety Audit**

- 12.3.1 A team comprising of the Contractor’s Senior SHE (Electrical) Engineer and the



Engineer shall conduct Electrical Safety Audit monthly covering the following and submit the report to the Engineer and the Employer. A monthly electrical audit format shall be designed by the Contractor with consent of the Engineer for this purpose.

- i) Electrical accidents investigation findings and remedy
- ii) Adequacy of power generation and power requirements
- iii) Power distribution and transmission system in place
- iv) Updated electrical single line diagram showing the current condition of power source and distribution including the IP44 DBs arrangement.
- v) Electrical protection devices - selection, installation and maintenance.
- vi) Earth or ground connection and earth pit maintenance details
- vii) Education and training of electrical personnel undertaken
- viii) Routine electrical inspection details
- ix) Safety Certificate in respect of Contractor's electrical systems and equipment
- x) Electrical maintenance system and register.
- xi) Name plate details of major electrical equipment
- xii) Classified zones in the site, if any.

#### **12.4 External SHE Audit**

- 12.4.1 External SHE audits are to be conducted by external agency appointed by the Employer that are competent with ISO qualified auditors with prior approval of the Employer.
- 12.4.2 The audit team shall have a practical understanding of BOCW Act and Rules, statutory requirements on health/medical and welfare of workmen, construction hazards and its prevention and control, traffic management, electrical safety, rigging, safety of construction equipment and environment management.
- 12.4.3 Audit shall be conducted on quarterly basis as per the guidelines of ISO, ILO and national standards. Audit report shall also be presented as per the above formats.
- 12.4.4 The contents and coverage of the external audit shall include the following items

SHE management:

- i) Organization
- ii) Communication and Motivation
- iii) Time office
- iv) Inspection
- v) Emergency preparedness
- vi) Budget allocation

- vii) Education and Training
- viii) Work permit system

Technical:

- i) Building and Structure
- ii) Construction operational safety
- iii) Material safety
- iv) Hand tools and Power tools
- v) Electrical system
- vi) Safety Appliances
- vii) Fire prevention and control
- viii) Housekeeping
- ix) Maintenance and Machinery safety
- x) First-aid and Medical Facilities
- xi) Welfare measures
- xii) Environmental and Social Management

12.4.5 Contractor shall make the below listed documents available for the review by the Audit team.

- i) SHE policy
- ii) SHE manual
- iii) SHE Rules and Regulation
- iv) SHE organization chart
- v) Annual SHE objectives / programs
- vi) Accident / near miss statistics and analysis
- vii) SHE Training program / records for all personnel
- viii) Operating manuals and maintenance manual of all equipment
- ix) Safe worthiness certificates of all lifting appliances and gears
- x) Medical fitness record for all personnel
- xi) Risk identification, assessment and control details
- xii) Environmental and social management reports
- xiii) Emergency management records including mock drill

12.4.6 Audit Preparation

- i) Audit team members are required to gather information by observations through interviews and by checks of hardware and documentation.
  - ii) Audit team shall prepare checklist to cover all parts based on SHE legislations rules and regulations and the DFCCIL Requirements.
  - iii) Audit team members shall verify the facts and findings leading to the identified gaps and weakness.
  - iv) Audit leader has overall responsibility for reaching a conclusion.
- 12.4.7 Audit report shall be prepared and directly sent to the Engineer and Employer within 7 days after conducting the audit with a copy to the Contractor.
- 12.4.8 The Audit Report shall have the following contents:
- i) Executive summary - based on the finalized checklists as written the findings to the Employer by the audit team members, the audit leader will compile a concise and accurate summary of observations and findings.
  - ii) Introduction - this will contain basic information regarding the facilities or organization audited, the specific audit dates (inclusion of those for preparation and post-audit activities).
  - iii) Principal positive findings - This will contain the summary of positive aspects as observed by the auditors. It will also contain highlights of those issue, which may warrant dissemination as best practice regarding methodology used or achievement.
  - iv) Audit Findings - All audit findings as detailed in the audit checklists shall be grouped together as priority 1 and 2 as detailed below in a separate listing.
  - v) Priority 1: Actions to rectify gaps or weakness should generally be implemented within two-weeks time, if risk potential is high or unacceptable.
  - vi) Priority 2: Actions should be generally implemented or rectified with a maximum of 3 – 4 weeks, if not rectified would create a likelihood of minor injury or business loss.
- 12.4.9 The auditor shall inspect the site after 14 days of conducting initial audit for checking the adequacy of implementation of items maintained under priority 1 by the Contractor and shall submit a conformity / non-conformity report to the Engineer and the Employer with a copy to the Contractor.
- 12.4.10 The auditor shall again inspect after 28 days of conducting initial audit for checking the adequacy of implementation of items mentioned under priority 2 by the Contractor and shall submit a conformity / non-conformity report to the Engineer and Employer with a copy to the Contractor.
- 12.4.11 In case of non-conformity of items mentioned by auditor, the Engineer/ Employer shall take necessary steps including stoppage of work. If the Contractor fails to conduct the external SHE audit in time, the Employer at the cost of the Contractor shall have it done.

### **13 SHE COMMUNICATION**

- 13.1.1 The Contractor shall make every effort to communicate the Safety, Occupational Health and Environment management measures through posters campaigns / billboards / banners / glow signs being displayed around the work site as part of the effort to raise safety awareness amongst to the work force. Posters should be in Hindi, English and a suitable prominent local language if it is other than Hindi. Posters / billboards / banners/ glow signs should be changed at least once in a month to maintain the impact.
- 13.1.2 The Contractor shall also observe important days as listed in General Instruction DFCCIL/SHE/GI/008 and printing and displaying safety signage and posters as listed to be referred in General Instruction DFCCIL/SHE/GI/009 in Attachment 9 [Reference for SHE Activities] to Clause 16 [SHE Requirements] of Specifications.
- 13.1.3 The list indicated are the minimum indications of the Employer and the Contractor is encouraged to further the SHE communication activities by formulating suitable reward schemes for safety performers and any other activities, which deem fit for the purpose.

### **14 SHE SUBMITTALS TO THE ENGINEER / EMPLOYER**

#### **14.1 Reporting**

- 14.1.1 The Contractor shall submit the following reports to the Engineer and the Employer periodically:
- i) Daily Reporting of Total No of Workmen (as given in Clause 16 (14.2))
  - ii) Monthly SHE Report (as given in Clause 16 (14.3))
  - iii) SHE Committee Meeting Minutes (as given in Clause 16 (8.6))
  - iv) SHE Inspection Reports
  - v) SHE Audit Reports
    - a) Monthly Audit Rating Score (MARS) Reports
    - b) External SHE Audit
    - c) Electrical Safety Audit
  - vi) Environmental and Social Monitoring Report

#### **14.2 Daily Reporting of Total No of Workmen**

- 14.2.1 The Contractor shall report to the Engineer the total nos. of workmen engaged by all including any subcontractor within 2 hours of starting of any shift in any day. This reporting shall be the primary duty of the CAPO and reporting shall be through tele-fax / email. The onus of checking the receipt of the same by the Engineer lies with the Contractor.

#### **14.3 Monthly SHE Report**

- 14.3.1 The Contractor shall prepare a monthly SHE report consisting of the following and submit 3 copies within 7th of the next month to the Engineer.

- i) Monthly man-hour details
- ii) Monthly accident / incident details
- iii) SHE Committee details
- iv) Details of SHE training conducted in the month
- v) SHE Inspection
- vi) SHE internal audit details like electrical audit etc.
- vii) SHE communication activities under taken in the month indicating the number of posters displayed and balance availability in stock.
- viii) Environmental and social monitoring details (Air quality / Noise)
- ix) Any environmental and social issue reported
- x) Toolbox talks details
- xi) PPE details: Quantity purchased, issued to the workmen and stock available.
- xii) Details on IP 44 panel boards, lighting poles, welding and cutting equipment, ladders, hoists, tools & tackles.
- xiii) Monthly Lux meter study results
- xiv) Housekeeping
- xv) Barricade maintenance details
- xvi) Nos. of critical excavations
- xvii) Health & Welfare activities
- xviii) Safety walk conducted by Contractors' representative in the month
- xix) SHE activities planned for the next month

## **15 ACCIDENT REPORTING AND INVESTIGATION**

### **15.1 Reporting to the Engineer and the Employer**

- 15.1.1 All accidents and dangerous occurrences shall immediately be informed verbally to the Engineer and the Employer. This will enable the Engineer/ Employer to reach the scene of accident / dangerous occurrences to monitor/assist any rescue work and/or start conducting the investigation process so that the evidences are not lost.
- 15.1.2 Reports of all accidents (fatal/injury) and dangerous occurrences shall also be sent within 24 hours as per a pre-consented format (to be proposed by the Contractor and Engineer's consent obtained).
- 15.1.3 No accident / dangerous occurrences is exempted from reporting to the Engineer/ Employer.
- 15.1.4 Any wilful delay in verbal and written reporting to the Engineer/Employer shall be

penalized as per relevant clause.

## **15.2 Reporting to Govt. Organisations**

15.2.1 In addition to the above verbal and written reporting to the Engineer / Employer, as per Rule 210 of BOCWR, notice of any accident to a worker at the building or construction site that: a) causes loss of life; or b) disables a worker from working for a period of 48 hours or more immediately following the accident; shall forthwith be sent by telegram, telephone, fax, or similar other means including special messenger within four hours in case of fatal accidents and 72 hours in case of other accidents, to:

- i) the Regional Labour Commissioner (central), wherein the Contractor has registered the firm/work
- ii) the Board with which the worker involved was registered as a beneficiary;
- iii) Director General, Min. of Labour and
- iv) the next of kin or other relative of the worker involved in the accident;

15.2.2 Further, notice of accident shall be sent in respect of an accident which: a) causes loss of life; or b) disables the injured worker from work for more than 10 days to:

- i) the officer-in-charge of the nearest police station;
- ii) the District Magistrate or, if the District Magistrate by order so desires, to the Sub-Divisional Magistrate

15.2.3 In case of an accident causing minor injury, first-aid shall be administered and the injured worker shall be immediately transferred to a hospital or other place for medical treatment.

15.2.4 Where any accident causing disablement that subsequently results in death, notice in writing of such death, shall be sent to the authorities mentioned in Clause 2.14.2.1 and 2.14.2.2 within 72 hours of such death.

## **15.3 Reporting of Dangerous Occurrences**

15.3.1 The following classes of dangerous occurrences shall be reported to the Inspector having jurisdiction, whether or not any disablement or death caused to the worker, namely:

- i) collapse or failure of lifting appliances, or hoist, or conveyors, or similar equipment for handling of building or construction material or breakage or failure of rope, chain or loose gears; or overturning of cranes used in construction work;
- ii) falling of objects from height;
- iii) collapse or subsidence of soil, tunnel, pipe lines, any wall, floor, gallery, roof or any other part of any structure, launching girder, platform, staging, scaffolding or means of access including formwork;
- iv) explosion of receiver or vessel used for storage of pressure greater than atmospheric pressure, of any gas or gases or any liquid or solid used as building material;

- v) fire and explosion causing damage to any place on construction site where building workers are employed;
  - vi) spillage or leakage of any hazardous substance and damage to their container;
  - vii) collapse, capsizing, toppling or collision of transport equipment;
  - viii) leakage or release of harmful toxic gases at the construction site;
- 15.3.2 In case of failure of launching girder, lifting appliance, loose gear, hoist or building and other construction work, machinery and transport equipment at a construction site, such appliances, gear, hoist, machinery or equipment and the site of such occurrence shall, as far as practicable, be kept undisturbed until inspected by the Authorities;
- 15.3.3 Every notice given for fatal accidents or dangerous occurrences shall be followed by a written report to the concerned Authorities under Section 39 of BOCWA and the Director General in the specified Form XIV of BOCWR.

#### **15.4 Accident Investigation**

- 15.4.1 Investigations should be conducted in an open and positive atmosphere that encourages the witnesses to talk freely. The primary objective is to ascertain the facts with a view to prevent future and possibly more serious occurrences
- 15.4.2 Accidents and Dangerous Occurrences which result in death, serious injury or serious damage shall be investigated by the Contractor immediately to find out the cause of the accident/occurrence so that measures can be formulated to prevent any recurrence.
- 15.4.3 Near misses and minor accidents should also be investigated by the Contractor as soon as possible as they are signals that there are inadequacies in the safety management system.
- 15.4.4 It is important after any accident or dangerous occurrence that information relating to the incident is gathered in an organised way. The following steps shall be followed;
- i) take photographs and make sketches
  - ii) examine involved equipment, work piece or material and the environmental conditions
  - iii) interview the injured, eye-witnesses and other involved parties
  - iv) consult expert opinion where necessary
  - v) identify the specific contractor or sub-contractor involved.
- 15.4.5 Having gathered information, it is then necessary to make an analysis of incident
- i) establish the chain of events leading to the accident or incident
  - ii) find out at what stage the accident took place
  - iii) consider all possible causes and the interaction of different factors that led up to the accident and identify the most probable cause The cause of an accident should never be classified as carelessness. The specific act or omission that caused the accident must be identified.

- 15.4.6 The next stage is to proceed with the follow-up action
- i) report on the findings and conclusions
  - ii) formulate preventive measures to avoid recurrence
  - iii) publicise the findings and the remedial actions taken

#### **15.5 Employers' Independent Incident Investigation**

- 15.5.1 In case of fatal / dangerous occurrence, the Employer may also conduct independent investigation. Contractor and his staff shall extend necessary co-operation and testify about the accident.
- 15.5.2 The Contractor shall take every effort to preserve the scene of accident till the Employer completes the investigation.
- 15.5.3 All persons summoned by the Employer in connection to witness recording shall obey the instructions without delay. Any willful suppression of information by any person shall be removed from the site immediately.

### **16 EMERGENCY RESPONSE PLAN**

- 16.1.1 The Contractor shall prepare an Emergency Response Plan for all work sites as a part of the Contractor's Project and Site SHE Plans. The plan shall integrate the Emergency Response Plan of the Contractor and all other subcontractors. The Emergency Response Plan shall detail the Contractor's procedures, including detailed communications arrangements, for dealing with all emergencies that could affect the Site. This include where applicable, injury, sickness, evacuation, fire, chemical spillage, severe weather and rescue.
- 16.1.2 The Contractor shall ensure that the Emergency Response Plan is prepared to deal with emergencies arising out of:
- i) Fire and explosion
  - ii) Collapse of lifting appliances and transport equipment
  - iii) Collapse of building, sheds or structure etc.
  - iv) Gas leakage or spillage of dangerous goods or chemicals
  - v) Bomb threatening, Criminal or Terrorist attack
  - vi) Falling from height / Drowning of workers
  - vii) Landslides getting workers buried, floods, Earthquake, storms and other natural calamities.
- 16.1.3 Arrangements shall be made for emergency medical treatment and evacuation of the victim in the event of an accident or dangerous incident occurring, the chain of command and the responsible persons of the Contractor with their telephone numbers and addresses for quick communication shall be adequately publicized and conspicuously displayed in the workplace.
- 16.1.4 Contractors shall require to tie-up with the hospitals and fire stations located in the neighborhood for attending to the casualties promptly and emergency vehicle kept on standby duty during the working hours for the purpose.



- 16.1.5 Contractor shall conduct an onsite emergency mock drill once in every month for all his workers and his subcontractor's workers.
- 16.1.6 It shall be the responsibility of the Contractor to keep the Local Law & Order Authorities informed and seek urgent help, as the case may be, so as to mitigate the consequences of an emergency. Prompt communication to the Engineer and the Employer, telephonically initially and followed by a written report, shall be made by the Contractor.

## **17 EXPERTS / AGENCIES FOR SHE SERVICES**

- 17.1.1 Contractors may utilise the services of experts/agencies empanelled under Rule 250 and Rule 297 of BOCWR for the purpose of training, internal audit and any other SHE services with prior approval of the Engineer / Employer.
- 17.1.2 As an aide to the Contractor, a list of experts/agencies and the offered service are suggested in General Instruction DFCCIL/SHE/GI/010 in Attachment 9 [Reference for SHE Activities] to Clause 16 [SHE Requirements] of Specifications for reference. In addition to it if the Contractor would like to use any expert/agencies' services for any SHE activities the same can also be allowed provided that they are competent and meet to the general requirements of Employer. In every case prior consent of the Engineer / Employer is mandatory.

### **Part III Labour Protection**

#### **18 GENERAL**

- 18.1.1 The Contractor shall comply in full with the project Workplace Policy on Labour Protection as described in Attachment 5 [Workplace Policy on Labour Protection] to Clause 16 [SHE Requirements] of Specifications as well as the specific requirements of the clauses hereunder.

#### **19 ENGAGEMENT OF STAFF AND LABOUR**

- 19.1.1 The Contractor shall engage appropriate staff and labour, local or otherwise to enable him to fulfil all his obligations under the contract in full. The Contractor shall be solely responsible for all matters relating to the engagement and welfare of all persons employed by him in relation to this project.
- 19.1.2 The Contractor shall give priority to the employment of local people in the construction workforce, especially those affected by land acquisition or resettlement and from disadvantaged households (those headed by women or disabled persons and/or those living below the official poverty level).
- 19.1.3 The Contractor shall obtain complete bio-data and maintain personal details of all employees, including but not limited to the name, age, gender, father's/husband's name, permanent home address, local address, phone number if any, designation, name and location of the work and shall submit the same to the Engineer before commencement of the work.
- 19.1.4 The Contractor shall ensure that the employees deployed by him in the premises of the Employer are physically and mentally fit and do not have any criminal record.

#### **20 RATES OF WAGES**

- 20.1.1 The Contractor shall pay rates of wages that are in line with current industry standards and local conditions.
- 20.1.2 The Contractor shall ensure payment of at least the minimum wages as prescribed and applicable from time to time under the Minimum Wages Act, 1948, in the presence of an authorised representative of the Engineer / Employer and shall maintain proper records of their timely disbursement. These records shall be preserved for a period of at least 3 years and made available even after the contract is over for any verification by the statutory authorities.
- 20.1.3 The Contractor shall inform his employees about the tax implications on their salary, wages, allowances, benefits and perquisites, under the laws of the country. The Contractor shall perform such duties as may be imposed on him by such laws, ensure deductions required by law and deposit all such deductions with the statutory authorities in the prescribed manner and within the stipulated period.

#### **21 CONDITIONS OF LABOUR**

- 21.1.1 The Contractor shall observe conditions of labour that are no less favourable than those established for the relevant trade or industry and which at least comply with model standing orders provided under the Industrial Employment (Standing Orders) Act, 1946.

- 21.1.2 During the course of the work, the Contractor shall afford all employees all basic rights enumerated in the conventions of the International Labour Organisation, including freedom of association, right to freedom from forced labour and right to freedom from discrimination on the basis of race, colour, sex, religion, political opinion and social origin.

## **22 PERSONS IN THE SERVICE OF THE EMPLOYER**

- 22.1.1 The Contractor shall not recruit or attempt to recruit staff or labour from amongst the personnel of the Employer or the Engineer.

## **23 SOCIAL SECURITY**

- 23.1.1 The Contractor shall extend all relevant social security benefits to his employees including but not necessarily limited to those specified in the following statutes:
- i) Employees Provident Fund and Miscellaneous Provisions Act, 1952;
  - ii) Payment of Gratuity Act, 1972;
  - iii) Employees State Insurance Act, 1948;
  - iv) Payment of Bonus Act, 1965;
  - v) Maternity Benefit Act, 1951.
- 23.1.2 The Contractor shall provide proof of coverage of his employees under the Employees Provident Fund and Miscellaneous Provisions Act 1952 and the Employees State Insurance Act 1948, via independent code numbers allotted to him by the Central Provident Fund Organisation and Employees State Insurance Corporation respectively, prior to his participation in the bidding process.
- 23.1.3 The Contractor shall provide a provident fund pass book to each employee and ensure payment to the Regional Provident Fund Commissioner of Provident Fund, Employees' Deposit-linked Insurance (EDLI) and pension dues as required by the Employees Provident Fund and Miscellaneous Provisions Act 1952.
- 23.1.4 The Contractor shall ensure payment of appropriate contributions under the Employees State Insurance Act 1948.
- 23.1.5 The Contractor shall provide proof of deductions as well as remittances of Provident Fund, EDLI, Pension, Employees State Insurance (ESI) contribution, administrative charges etc, wherever applicable by law and shall maintain proper records.
- 23.1.6 The Contractor shall furnish proper returns to the concerned statutory authorities.
- 23.1.7 The Contractor is solely responsible for any non-payment/delayed payment of wages or contributions under the Employees Provident Fund and Miscellaneous Provisions Act, Employees State Insurance Act etc.
- 23.1.8 The Contractor shall comply with all other relevant conditions of the applicable legislation.
- 23.1.9 If the Contractor fails to make payment of wages to his employees or remittance of contribution to the concerned authorities, the security deposit and/or other dues under the Contract can be utilized by the Employer to discharge the Contractor's liability.

23.1.10 The Contractor shall insure all his employees under Group Personal Accident Insurance scheme through a recognised and registered insurance company.

## **24 LABOUR LAWS**

24.1.1 The Contractor shall comply with all relevant labour laws applicable to his personnel including but not necessarily limited to laws relating to employment, wages, health, safety, welfare, immigration and emigration and shall allow employees all their legal rights.

24.1.2 The Contractor shall ensure that all his employees and sub-contractors obey applicable laws and regulations, including those concerning safety at work.

24.1.3 The Contractor shall comply with all statutory requirements including but not necessarily limited to those contained in the following:

- i) Minimum Wages Act, 1948;
- ii) Payment of Wages Act, 1936;
- iii) Equal Remuneration Act, 1976;
- iv) Employees Provident Fund and Miscellaneous Provisions Act, 1952;
- v) Payment of Gratuity Act, 1972;
- vi) Employees State Insurance Act, 1948;
- vii) Payment Of Bonus Act, 1965;
- viii) Maternity Benefit Act, 1951;
- ix) Industrial Disputes Act, 1947;
- x) Industrial Employment (Standing Orders) Act, 1946;
- xi) Trade Unions Act, 1926;
- xii) Child Labour (Prohibition and Regulation) Act, 1986;
- xiii) Building and Other Construction Workers (Regulation of Employment of Service) Act 1996;
- xiv) Building and Other Construction Workers Cess Act of 1996;
- xv) The Contract Labour (Regulation and Abolition) Act, 1970;
- xvi) Inter State Migrant Workmen's (Regulation of Employment and Conditions of Service ) Act ,1979;
- xvii) Workmen Compensation Act. 1923;
- xviii) Factories Act, 1948;
- xix) Mines Act, 1952.

24.1.4 The Contractor shall comply with all other statutory requirements, rules, regulations and notifications in relation to employment of his staff and workers that may be issued from time to time by the concerned government authorities.

## **25 WORKING HOURS**

- 25.1.1 No work shall be carried out beyond the statutory limit given under BOCWA 1996.
- 25.1.2 No work shall be carried out outside the normal working hours stated in contract unless:
- i) Otherwise stated in the contract;
  - ii) The Engineer gives his consent in writing;
  - iii) The work is unavoidable or necessary for the protection of life or property or for the safety of the works, in which case the Contractor shall immediately inform the Engineer.
- 25.1.3 Notwithstanding the above, no work shall be carried out in contravention of applicable laws barring any exceptions and exemptions provided under the particular law.

## **Part IV Safety**

### **26 HOUSEKEEPING**

- 26.1.1 Housekeeping is the act of keeping the working environment cleared of all unnecessary waste, thereby providing a first-line of defence against accidents and injuries.
- 26.1.2 Contractor shall understand and accept that improper housekeeping is the primary hazard in any construction site and ensure that a high degree of housekeeping is always maintained. Indeed “Cleanliness is next to Godliness”
- 26.1.3 Housekeeping is the responsibility of all site personnel and line management commitment shall be demonstrated by the continued efforts of supervising staff towards this activity.
- 26.1.4 General Housekeeping shall be carried out by the Contractor and ensured at all times at Work Site, Construction Depot, Batching Plant, Labour Camp, Stores, Offices and toilets/urinals. Towards this the Contractor shall constitute a special group of housekeeping personnel as per General Instruction DFCCIL/SHE/GI/001 in Attachment 9 [Reference for SHE Activities] to Clause 16 [SHE Requirements] of Specifications. This group shall ensure daily cleaning at work sites and surrounding areas and maintain a register as per format consented by the Engineer.
- 26.1.5 Adequate time shall be assigned to ensure that good housekeeping is maintained. This shall be carried out by the team of housekeeping squad.
- 26.1.6 The Contractor shall be responsible to provide segregated containers for disposal of debris at required places and regular cleaning of the same.
- 26.1.7 In areas used by public, full height fence, barriers, barricades etc. shall be erected around the site in order to prevent the surrounding area from excavated soil, rubbish etc, which may cause inconvenience to and endanger the public. The barricade especially those exposed to public shall be aesthetically maintained by regular cleaning and painting as directed by the Engineer. These shall be maintained in one line and level.
- 26.1.8 The structure dimension of the barricade, material and composition, its colour scheme, DFCCIL logo and other details shall be developed by the Contractor in reference to documents and drawings provided in the Contract Package.
- 26.1.9 All stairways, passageways and gangways shall be maintained without any blockages or obstructions. All emergency exits passageways, exits fire doors, break-glass alarm points, fire fighting equipment, first aid stations and other emergency stations shall be kept clean, unobstructed and in good working order.
- 26.1.10 Lumber with protruding nails shall be either bent or removed and properly stacked. Unpacked wooden strips shall be safely stored and disposed.
- 26.1.11 All surplus earth and debris are removed/disposed off from the working areas to officially designated dumpsites. Trucks carrying sand, earth and any pulverized materials etc. in order to avoid dust or odour impact shall be covered while moving. The tyres of the trucks leaving the site shall be cleaned with water, wherever the possibility of spillage on carriageways meant for regular road traffic exists.
- 26.1.12 No parking of trucks/trolleys, cranes and trailers etc. shall be allowed on roads, which may obstruct the traffic movement.
- 26.1.13 Roads shall be kept clear and materials like: pipes, steel, sand boulders, concrete,

chips and brick etc., shall not be allowed on the roads which obstruct free movement of road traffic.

- 26.1.14 Water logging or bentonite spillage on roads shall not be allowed. If bentonite spillage is observed on road endangering the safety of road users, the Contractor shall immediately carry out the corrective measures on his own costs. Proper and safe stacking of material are of paramount importance at yards, stores and such locations where material would be unloaded for future use. The storage area shall be well laid out with easy access and material stored / stacked in an orderly and safe manner.
- 26.1.15 Flammable chemicals / compressed gas cylinders shall be safely stored.
- 26.1.16 Unused/surplus cables, steel items and steel scrap lying scattered at different places within the working areas shall be removed to identified locations(s).
- 26.1.17 All wooden scrap, empty wooden cable drums and other combustible packing materials, shall be removed from work place to identified location(s).
- 26.1.18 Empty cement bags and other packaging material shall be properly stacked and removed.
- 26.1.19 The Contractor shall ensure that all his sub-contractors maintain the site reasonably clean through provisions related to house keeping

## **27 WORK AT HEIGHT**

### **27.1 Definitions**

- 27.1.1 "access" and "egress" include ascent and descent.
- 27.1.2 "fragile surface" means a surface, which would be able to fail if any reasonably foreseeable loading were to be applied to it.
- 27.1.3 "line" includes rope, chain or webbing
- 27.1.4 "personal fall protection" means -
  - i) a fall prevention, work restraint, work positioning, fall arrest or rescue system, other than a system in which the only safeguards are collective safeguards; or
  - ii) rope access and positioning techniques;
- 27.1.5 "work at height" means -
  - i) work in any place, including a place at or below ground level;
  - ii) obtaining access to or egress from such place while at work, except by a staircase in a permanent workplace,  
  
where, if protective measures were not taken, a person could fall a distance liable to cause personal injury;
- 27.1.6 "work equipment" means any machinery, appliance, apparatus, tool or installation for use at work (whether exclusively or not) and includes
  - i) a guard-rail, toe-board, barrier or similar collective means of protection

- ii) a working platform
- iii) a net, airbag or other collective safe guard for arresting falls.
- iv) personal fall protection system
- v) ladders

27.1.7 “working platform”

- i) means any platform used as a place of work or as a means of access to or egress from a place of work;
- ii) includes any scaffold, suspended scaffold, cradle, mobile platforms, trestle, gangway, gantry and stairway which is so used.

**27.2 Organisation and Planning**

27.2.1 The Contractor shall ensure that work at height is

- i) properly planned for any emergencies and rescue
- ii) appropriately supervised and
- iii) carried out in a manner, which is reasonably practicable safe.

27.2.2 The Contractor shall ensure that work at height is carried out only when the weather conditions do not jeopardise the health or safety of persons involved in the work.

**27.3 Competence**

27.3.1 The Contractor shall ensure that no person engages in any activity, including organization, planning and supervision, in relation to work at height or work equipment for use in such work unless he is competent to do so or, if being trained, is being supervised by a competent person.

**27.4 Accident Prevention Measures**

27.4.1 The Contractor shall formulate accident preventive measures taking into account of envisaged conditions, situations and particular activities of the Works which may induce accidents. Then the Contractor shall plan and programme the measures to be implemented in all Work Areas in various construction stages. The Contractor is responsible for incorporating the accident prevention measures against the Work at Height into the SHE activities and efficiently carry out the measures in a practical manner.

**27.5 Inspection of Work Equipment**

27.5.1 The Contractor shall ensure that, where the safety of work equipment depends on how it is installed or assembled, it is not used after installation or assembly in any position unless it has been inspected in that position.

27.5.2 The Contractor shall ensure that work equipment exposed to conditions causing deterioration which is liable to result in dangerous situations is inspected

- i) at suitable intervals and
- ii) each time that exceptional circumstances which are liable to jeopardise the safety of the work equipment have occurred,



to ensure that health and safety conditions are maintained and that any deterioration can be detected and remedied in good time.

27.5.3 Without prejudice to Clause 16 (27.9.1), the Contractor shall ensure that a working platform

- i) used for construction work and
- ii) from which a person could fall 2 metres or more,

is not used in any position unless it has been inspected in that position or, in the case of a mobile working platform, inspected on the site, within the previous 7 days.

27.5.4 The Contractor shall ensure that the reports of all inspections are properly maintained and shown to the Engineer as and when required.

27.5.5 In this clause "inspection",

- i) means such visual or more rigorous inspection by a competent person as is appropriate for safety purposes;
- ii) includes any testing appropriate for those purposes,

## **27.6 Inspection of Places of Work at Height**

27.6.1 The Contractor shall so far as is reasonably practicable ensure that the surface and every parapet, permanent rail or other such fall protection measure of every place of work at height are checked on each occasion before the place is used.

## **27.7 Duties of Persons at Work**

27.7.1 Any workmen employed by the Contractor shall report to the supervisor about any defect relating to work at height which he knows is likely to endanger the safety of himself or another person.

27.7.2 Every workmen shall use any work equipment or safety device provided to him for work at height by the Contractor, in accordance with

- i) any training in the use of the work equipment or device concerned which have been received by him and
- ii) the instructions respecting that use which have been provided to him by the Contractor as per the requirements of the Employer

## **27.8 Requirements for Existing Places of Work and Means of Access or Egress at Height**

27.8.1 Every existing place of work or means of access or egress at height shall

- i) be stable and of sufficient strength and rigidity for the purpose for which it is intended to be or is being used;
- ii) where applicable, rest on a stable, sufficiently strong surface;
- iii) be of sufficient dimensions to permit the safe passage of persons and the safe use of any plant or materials required to be used and to provide a safe working area having regard to the work to be carried out there;

- iv) possess suitable and sufficient means for preventing a fall;
- v) possess a surface which has no gap
  - a) through which a person could fall;
  - b) through which any material or object could fall and injure a person;  
or
  - c) giving rise to other risk of injury to any person, unless measures have been taken to protect persons against such risk;
- vi) be so constructed and used and maintained in such condition, as to prevent, so far as is reasonably practicable -
  - a) the risk of slipping or tripping; or
  - b) any person being caught between it and any adjacent structure;
- vii) where it has moving parts, be prevented by appropriate devices from moving inadvertently during work at height.

**27.9 Requirements for Guardrails, Toe-boards, Barriers and Similar Collective Means of Protection**

27.9.1 Unless the context otherwise requires, any reference in this section to means of protection is to a guardrail, toe-board, barrier or similar collective means of protection.

27.9.2 Means of protection shall

- i) be of sufficient dimensions, of sufficient strength and rigidity for the purposes for which they are being used and otherwise suitable;
- ii) be so placed, secured and used as to ensure, so far as is reasonably practicable, that they do not become accidentally displaced and
- iii) be so placed as to prevent, so far as is practicable, the fall of any person, or of any material or object, from any place of work.

27.9.3 In relation to work at height involved in construction work

- i) the top guard-rail or other similar means of protection shall be at least 950 millimetres above the edge from which any person is liable to fall;
- ii) toe-boards shall be suitable and sufficient to prevent the fall of any person, or any material or object, from any place of work and
- iii) any intermediate guardrail or similar means of protection shall be positioned so that any gap between it and other means of protection does not exceed 470 millimetres.

27.9.4 Any structure or part of a structure which supports means of protection or to which means of protection are attached shall be of sufficient strength and suitable for the purpose of such support or attachment.

**27.10 Requirements for All Working Platforms**

27.10.1 Every working platforms requires a supporting structure for holding it

27.10.2 Any surface upon which any supporting structure rests shall be stable, of sufficient

strength and of suitable composition safely to support the supporting structure, the working platform and any loading intended to be placed on the working platform.

27.10.3 Stability of supporting structure: any supporting structure shall

- i) be suitable and of sufficient strength and rigidity for the purpose for which it is being used;
- ii) in the case of a wheeled structure, be prevented by appropriate devices from moving inadvertently during work at height;
- iii) in other cases, be prevented from slipping by secure attachment to the bearing surface or to another structure, provision of an effective anti-slip device or by other means of equivalent effectiveness;
- iv) be stable while being erected, used and dismantled and
- v) when altered or modified, be so altered or modified as to ensure that it remains stable.
- vi) Have suitable base plates and properly footed thereby.

27.10.4 Stability of working platforms: a working platform shall

- i) be suitable and of sufficient strength and rigidity for the purpose or purposes for which it is intended to be used or is being used;
- ii) be so erected and used as to ensure that its components do not become accidentally displaced so as to endanger any person;
- iii) when altered or modified, be so altered or modified as to ensure that it remains stable and
- iv) be dismantled in such a way as to prevent accidental displacement.

27.10.5 Safety on working platforms: a working platform shall

- i) be of sufficient dimensions to permit the safe passage of persons and the safe use of any plant or materials required to be used and to provide a safe working area having regard to the work being carried out there;
- ii) possess a suitable surface and, in particular, be so constructed that the surface of the working platform has no gap
  - a) through which a person could fall;
  - b) through which any material or object could fall and injure a person;  
or
  - c) giving rise to other risk of injury to any person, unless measures have been taken to protect persons against such risk and
- iii) be so erected and used and maintained in such condition, as to prevent, so far as is reasonably practicable
  - a) the risk of slipping or tripping; or
  - b) any person being caught between the working platform and any adjacent structure.

- 27.10.6 Loading: a working platform and any supporting structure shall not be loaded so as to give rise to a risk of collapse or to any deformation, which could affect its safe use.
- 27.10.7 Additional requirements for scaffolding: strength and stability calculations for scaffolding shall be carried out unless
- i) a note of the calculations, covering the structural arrangements contemplated, is available; or
  - ii) it is assembled in conformity with a generally recognised standard configuration.
- 27.10.8 Depending on the complexity of the scaffolding selected, a competent person shall draw up an assembly, use and dismantling plan. This may be in the form of a standard plan, supplemented by items relating to specific details of the scaffolding in question.
- 27.10.9 A copy of the plan, including any instructions it may contain, shall be kept available for the use of persons concerned in the assembly, use, dismantling or alteration of scaffolding until it has been dismantled.
- 27.10.10 The dimensions, form and layout of scaffolding decks shall be appropriate to the nature of the work to be performed and suitable for the loads to be carried and permit work and passage in safety.
- 27.10.11 While a scaffold is not available for use, including during its assembly, dismantling or alteration, it shall be marked with general warning signs in accordance with and be suitably delineated by physical means preventing access to the danger zone.
- 27.10.12 Scaffolding may be assembled, dismantled or significantly altered only under the supervision of a competent person and by persons who have received appropriate and specific training in the operations envisaged which addresses specific risks which the operations may entail and precautions to be taken and more particularly in
- i) understanding of the plan for the assembly, dismantling or alteration of the scaffolding concerned;
  - ii) safety during the assembly, dismantling or alteration of the scaffolding concerned;
  - iii) measures to prevent the risk of persons, materials or objects falling;
  - iv) safety measures in the event of changing weather conditions which could adversely affect the safety of the scaffolding concerned;
  - v) permissible loadings;
  - vi) any other risks which the assembly, dismantling or alteration of the scaffolding may entail.

#### **27.11 Requirements for Collective Safeguards for Arresting Falls**

- 27.11.1 Collective safeguard are a safety net, airbag or other collective safeguard for arresting falls.
- 27.11.2 A safeguard shall be used only if
- i) a risk assessment has demonstrated that the work activity can so far as is reasonably practicable be performed safely while using it and without affecting its effectiveness;

- ii) the use of other, safer work equipment is not reasonably practicable and
  - iii) a sufficient number of available persons have received adequate training specific to the safeguard, including rescue procedures.
- 27.11.3 A safeguard shall be suitable and of sufficient strength to arrest safely the fall of any person who is liable to fall.
- 27.11.4 A safeguard shall
- i) in the case of a safeguard which is designed to be attached, be securely attached to all the required anchors and the anchors and the means of attachment thereto shall be suitable and of sufficient strength and stability for the purpose of safely supporting the foreseeable loading in arresting any fall and during any subsequent rescue;
  - ii) in the case of an airbag, landing mat or similar safeguard, be stable and
  - iii) in the case of a safeguard, which distorts in arresting a fall, afford sufficient clearance.
- 27.11.5 Suitable and sufficient steps shall be taken to ensure, so far as practicable, that in the event of a fall by any person the safeguard does not itself cause injury to that person.

## **27.12 Requirements for Personal Fall Protection Systems**

- 27.12.1 A personal fall protection system shall be used only if
- i) a risk assessment has demonstrated that
    - a) the work can so far as is reasonably practicable be performed safely while using that system and
    - b) the use of other safer work equipment is not reasonably practicable and
  - ii) the user and a sufficient number of available persons have received adequate training specific to the operations envisaged, including rescue procedures.
- 27.12.2 A personal fall protection system shall
- i) be suitable and of sufficient strength for the purposes for which it is being used having regard to the work being carried out and any foreseeable loading;
  - ii) where necessary, fit the user;
  - iii) be correctly fitted;
  - iv) be designed to minimise injury to the user and, where necessary, be adjusted to prevent the user falling or slipping from it, should a fall occur and
  - v) be so designed, installed and used as to prevent unplanned or uncontrolled movement of the user.
- 27.12.3 A personal fall protection system designed for use with an anchor shall be securely attached to at least one anchor and each anchor and the means of attachment thereto

shall be suitable and of sufficient strength and stability for the purpose of supporting any foreseeable loading.

27.12.4 Suitable and sufficient steps shall be taken to prevent any person falling or slipping from a personal fall protection system.

### **27.13 Requirements for Ladders**

27.13.1 Every contractor shall ensure that a ladder is used for work at height only if a risk assessment has demonstrated that the use of more suitable work equipment is not justified because of the low risk and

- i) The short duration of use; or
- ii) Existing features on site, which he cannot alter.

27.13.2 Only metal ladders shall be allowed. Bamboo ladders are prohibited.

27.13.3 Any surface upon which a ladder rests shall be stable, firm, of sufficient strength and of suitable composition safely to support the ladder so that its rungs or steps remain horizontal and any loading intended to be placed on it.

27.13.4 A ladder shall be so positioned as to ensure its stability during use

27.13.5 A suspended ladder shall be attached in a secure manner and so that, with the exception of a flexible ladder, it cannot be displaced and swinging is prevented.

27.13.6 A portable ladder shall be prevented from slipping during use by -

- i) securing the stiles at or near their upper or lower ends;
- ii) an effective anti-slip or other effective stability device; or
- iii) any other arrangement of equivalent effectiveness.

27.13.7 A ladder used for access shall be long enough to protrude sufficiently above the place of landing to which it provides access, unless other measures have been taken to ensure a firm handhold.

27.13.8 No interlocking or extension ladder shall be used unless its sections are prevented from moving relative to each other while in use.

27.13.9 A mobile ladder shall be prevented from moving before it is stepped on.

27.13.10 Where a ladder or run of ladders raises a vertical distance of 9 metres or more above its base, there shall, where reasonably practicable, be provided at suitable intervals sufficient safe landing areas or rest platforms.

27.13.11 Every ladder shall be used in such a way that

- i) a secure handhold and secure support are always available to the user and
- ii) the user can maintain a safe handhold when carrying a load unless, in the case of a step ladder, the maintenance of a handhold is not practicable when a load is carried and a risk assessment has demonstrated that the use of a stepladder is justified because of
  - a) the low risk and

- b) the short duration of use.

## **28 OVERHEAD PROTECTION**

- 28.1.1 All contractors shall provide overhead protections as per Rule 41 of BOCWR.
- 28.1.2 Overhead protection should be erected along the periphery of every building which is under construction and the building height shall be 15m or above after construction.
- 28.1.3 Overhead protection shall be minimum 2m wide and the outer edge shall be 150mm higher than the inner edge and an angle not more than 20 degrees to its horizontal sloping into the building.
- 28.1.4 Overhead protection shall not be erected more than a height of 5m from the base of the building.
- 28.1.5 Areas of inadvertent hazard of falling of material shall be guarded or barricaded or roped-off thereby by the Contractor.

## **29 SLIPPING, TRIPPING, CUTTING, DROWNING AND FALLING HAZARDS**

### **29.1 As per Rule 42 of BOCWR,**

- i) All places should be free from dust, debris or similar materials.
- ii) Sharp projections or any protruding nails or similar objects shall be suitably guarded or shall even be avoided to make the place safe to work.
- iii) Contractor shall not allow workmen to work or use platforms, scaffolds/passageways or any walkways, which has water, or oil or similar substances spilt and has a slipping hazard, unless it is cleaned off or covered or sanded or saw dusted or make it safe with any suitable material.
- iv) When workers are exposed to areas where fall into water is possible, the Contractor shall provide suitable and adequate equipment for saving the workers from drowning and rescuing from such hazard. If the Engineer considers, the Contractor shall provide well-equipped boat or launch, manned with trained personnel at the work place.
- v) Open side or opening where worker, equipment, vehicle or lifting appliance may fall at a building or outside shall be guarded suitably except in places of free access by reasons of nature of work.
- vi) Suitable safety net shall be provided at places of material / man falling is possible in accordance with national standards.

## **30 LIFTING APPLIANCES AND GEAR**

### **30.1 General**

- 30.1.1 Lifting appliances means a crane, hoist machinery, derrick, winch, gin pole, sheer legs, jack, hoist drum, slewing machinery, slewing bearing fasteners, luffing machinery sheaves, pulley blocks, hooks or other equipment used for lifting materials, objects or building workers and lifting gears means ropes, chain slings, shackles, hooks, lifting

lugs, wire ropes, lifting eyebolts and eyenuts and other accessories of a lifting appliance.

30.1.2 No machine shall be selected to do any lifting on a specific job until its size and characteristics are considered against:

- i) the weights, dimensions and lift radii of the heaviest and largest loads
- ii) the maximum lift height, the maximum lift radius and the weight of the loads that shall be handled at each
- iii) the number and frequency of lifts to be made
- iv) how long the crane will be required on site
- v) the type of lifting to be done (for example, is precision placement of loads (important)
- vi) the type of carrier required (this depends on ground conditions and machine capacity In its operating quadrants: capacity is normally greatest over the rear, less over the side and non-existent over the front)
- vii) whether loads will have to be walked or carried
- viii) whether loads will have to be suspended for lengthy periods
- ix) the site conditions, including the ground where the machine will be set up, access roads and ramps it must travel, space for erection and any obstacles that might impede access or operation

30.1.3 The Contractor shall ensure that a valid certificate of fitness issued as per Cause 16 (30.1.4) is available for all lifting appliances including synchronised mobile jacks, pre-stressing hydraulic jacks, jacks fitted with launching girders etc. and the Engineer's consent before inducting to the site. Only after obtaining the Engineer's consent, any lifting appliances and gear shall be used.

30.1.4 The laminated photocopies of fitness certificate issued by competent person, the Engineer's approval letter, the operators' photo, manufacturer's load chart and competency certificate shall always be either kept in the operator cabin or pasted on the visible surface of the lifting appliances.

30.1.5 All lifting appliances and loose gears shall be clearly marked for its safe working load and identification by stamping or other suitable means.

30.1.6 The Contractor shall also maintain a register containing a system of identification of all tools and tackles, its date of purchase, safe working load, competent person date of examination etc.

30.1.7 At least one trained banksman shall be in attendance at each lifting or hoisting installation.

30.1.8 All lifting hooks shall have a safety latch.

### **30.2 Test and Periodical Examination of Lifting Appliances and Gears**

30.2.1 All lifting appliances including all parts and gears thereof, whether fixed or movable shall be thoroughly tested and examined by a competent person once at least in every six months or after it has undergone any alterations or repairs liable to affect its strength or stability. Within the validity, if the lifting appliances are shifted to a new site, re-



examination by the same competent person for ensuring its safety shall also be done.

- 30.2.2 Contractors can utilise the services of any competent person as defined in BOCW Act, 1996 or Factories Act, 1948, or Dock Safety Act, 1987 and approved by corresponding act approving authority or any other equivalent agency with the permission of the Engineer.
- 30.2.3 All alarms and signals like automatic safe load indicators (SLI), boom angle indicators, boom extension indicators, over lift boom alarm, swing alarm, hydraulic safety valves, mechanical radius indicators, load moment indicators etc. shall be periodically examined and maintained always in working condition

### **30.3 Automatic Safe Load Indicators**

- 30.3.1 As stipulated in Rule 57 of BOCWR, every lifting appliances and gears like cranes, hydras etc, if so constructed that the safe working load may be varied by raising or lowering of the jib or otherwise shall be attached with an automatic indicator of safe working loads approved by Bureau of Indian standards/ International certifying bodies which gives a warning to the operator and arrests further movements of the lifting parts.

### **30.4 Qualification of Operator of Lifting Appliances and of Signaller etc.**

- 30.4.1 The Contractor shall not employ any person to drive or operate a lifting machine like crane, hydra etc whether driven by mechanical power or otherwise or to give signals to work as a operator of a rigger or derricks unless he
- i) is above twenty-one years of age and possesses a valid heavy transport vehicle driving license as per Motor Vehicle Act and Rules.
  - ii) is absolutely competent and reliable
  - iii) possesses the knowledge of the inherent risks involved in the operation of lifting appliances by undergoing a formal training at any institution of national importance acceptable to the Engineer.
  - iv) is medically examined periodically as specified in schedule VII of BOCW Rules.

### **30.5 General Requirements of Appliances**

- 30.5.1 Out-of level: one of the most severe effects of being out-of fit level is that side loads develop in the boom. Because of side loads all mobile cranes lose capacity rapidly as the degree of out-of-level increases and therefore
- 30.5.2 Boom
- i) The boom is one of the more critical elements of the crane and shall be in perfect condition at all time. No boom section with a bent lattice member shall be allowed
  - ii) All welds shall be crack and corrosion free
  - iii) No member of the boom shall be bent
  - iv) All telescopic boom shall be free from cracks, rust, flaking or cracked paint, bulges, greases or varnishes
- 30.5.3 The sweep area (work area) of the construction machinery shall be always free from obstructions.

- 30.5.4 All hydraulic piping and fittings shall be maintained leak proof.
- 30.5.5 The operator cab shall possess good and safe:
- i) structure, windows and windshield wipers
  - ii) Drivers chair and foot rest
  - iii) Control handles
  - iv) Cab instrumentation
  - v) Telecommunication
  - vi) Cab outfitting
  - vii) wind indicator with an adjustable set point shall be in a position representative for the wind on the crane. The indicator shall give continuous information regarding constant speeds and gusts.

### **30.6 Mandatory Rigging Requirements**

- 30.6.1 Rigging shall be done under experienced and qualified rigger only.
- 30.6.2 The primary requirement in rigging shall be to assess the weight of load before attempting any lift.
- 30.6.3 All hooks shall be fitted with Master Rings having certificate of fitness from the competent person, so that the hooks are subjected to balanced vertical loading only.
- 30.6.4 Only four legged slings shall be allowed which includes master link (ring), intermediate master link (ring) if necessary, chain / wire rope sling, sling hook or other terminal fitting.
- 30.6.5 Hand spliced slings up to 32mm diameter shall not be used at site for any lifting purpose.
- 30.6.6 No load shall be slewed over public areas without stopping the pedestrians and road traffic first.
- 30.6.7 Requirements of outriggers
- i) All outriggers shall be fully extended and at all tyres are clear of the ground
  - ii) Heavy duty blocking having large bearing area shall be necessary to prevent sinking of floats
- 30.6.8 All loads shall have tag-lines attached in order to ensure that the load can be controlled at all times.
- 30.6.9 No close working to any live overhead power line is permitted without the operation of a strict Permit to Work.
- 30.6.10 Minimum lighting is to be ensured at all lifting operations.

## **31 LAUNCHING OPERATION**

- 31.1.1 As launching operation is one of the riskiest job, the Contractor shall take utmost precaution at all stages like; planning, establishing casing yard, casting segments,

transporting segments, fabrication and erection of launching girders, if any, launching of segments / lifting of segments, pre-stressing, auto launching of girders and dismantling of launching girders.

- 31.1.2 The Contractor shall prepare a comprehensive Method Statement for the launching operation, adhering to the SHE conditions laid down herein. Particular reference shall be made to the provisions on working at height. As the entire process of launching/lifting has to be undertaken at the Site especially during night time, the safety of workers is of paramount important. The following general guidelines shall be adhered throughout the launching operation.
- i) Necessary 'working platforms' and fall protection anchorage arrangement shall be provided in the launching girder itself.
  - ii) Provisions for mounting light fittings shall also be made available in the launching girder.
  - iii) The casting yard shall be established ensuring the provision given in Clause 16 (4.22).
  - iv) The workmen engaged in fabrication of reinforcement, concreting the segment shall be provided with necessary PPEs including compulsory hand protection gloves.
  - v) Casting and curing of segment shall be undertaken under the direct supervision of the responsible engineer of the Contractor.
  - vi) Trucks with valid registration, license, safe worthiness certificate, Engineer's approval certificate and pollution under check certificate shall only be used for transport of segments.
  - vii) Drivers engaged for driving these trucks, shall be trained once in 6 months at Automobile Association of Western India or other organisation identified by the Engineer on defensive driving.
  - viii) Drivers shall also have undergone proper medical examination as per relevant clause mentioned under 'Medical Facilities'.
  - ix) The segments shall be rigidly secured to the truck with necessary wooden wedges and necessary red indicators/safety tapes provided so that the vehicle is clearly seen by other road users both in day / night time.
  - x) Every launching girder/lifting process shall have a responsible engineer on duty all the time.
  - xi) All the time from erection to dismantling, the area between the two piers wherein launching is in progress shall always be barricaded.
  - xii) Unloading of segments from trucks, lifting of segments, shifting of segments, gluing shall be done under the direct supervision of the approved engineer of the Contractor.
  - xiii) Auto launching shall be done only after consent of the Engineer to the scheme. After every auto launching the stability of launching girder shall be ensured.

- xiv) The vertical deflection of launching girder shall be monitored at all critical stages like with/without loads and after every auto launching.
- xv) A register containing all important operational details from erection to dismantling of launching girders shall be maintained and made available to Engineer whenever called for.
- xvi) Test certificate for all lifting gears including Macalloy bars, if any, shall be maintained at a location closer to the launching girder itself so that it can be referred during all inspections.
- xvii) Adequate lighting at all time shall be ensured in the entire area of operation.
- xviii) Access to drinking water & toilet shall be ensured to all workmen engaged for launching process.
- xix) Proper access ladders/stairways shall be maintained for safe ascending / descending of workmen / engineers.

## **32 CONSTRUCTION MACHINERY**

### **32.1 General**

- 32.1.1 Construction machineries may include dumpers and dump trucks, lift trucks and telescopic handlers, transit mixers, batching & mixing plants, crushers, concrete pumps, piling rigs, vibro hammers, rail welding equipment, mobile elevating work platforms, cranes, tipper lorries, lorry loaders, skip wagons, 360° excavators, 180° backhoe loaders, crawler tractors, scrapers, graders, loading shovels, trenchers, side booms, pavers, planers, chippers, road rollers, locomotives, tankers and bowsers, trailers, hydraulic and mechanical breakers etc.

### **32.2 Safe Worthiness Certificate**

- 32.2.1 Each construction equipment shall be in sound mechanical working condition and certified by either competent person under Factories Act or carry manufacturers' warranty in case of brand new equipment or authorized persons / firms approved by Engineer before induction to any site.
- 32.2.2 Every such certificate shall have the date of purchase, main overhauling undertaken in the past, any accident to the equipment, visual examination details, critical components safety check, list of safety devises and its working condition, manufacturer's maintenance checklist, past projects wherein the equipment were used etc as its minimum content.

### **32.3 Reverse Horns**

- 32.3.1 All Vehicles shall be fitted with audible reverse alarms and maintained in good working condition. Reversing shall be done only when there is adequate rear view visibility or under the directions of a banksman.

### **32.4 General Operating Procedures**

- 32.4.1 Drivers entering site shall be instructed to follow the safe system of work adopted on site. These shall be verbal instructions or, preferably, written instructions showing the relevant site rules, the site layout, delivery areas, speed limits, etc.

- 32.4.2 No passengers shall be carried, unless specific seating has been provided in accordance with the manufacturers recommendations.
- 32.4.3 Working on gradients beyond any equipment capability shall not be allowed.
- 32.4.4 Prevention of dumper and dump truck accidents should be managed by providing for adequate lateral clearances, wheel stops at a sufficient distance from the edges of excavations, spoil heaps, pits, markers, etc.
- 32.4.5 The manufacturer's recommended bucket size shall not be exceeded in excavators.
- 32.4.6 If excavators operating on a gradient which cannot be avoided, it shall be ensured that the working cycle is slowed down, that the bucket is not extended too far in the downhill direction and that travel is undertaken with extreme caution. A large excavator shall never be permitted to travel in a confined area, or around people, without a banksman to guide the driver, who should have the excavator attachment close in to the machine, with the bucket just clear of the ground. On wheeled excavators, it is essential that the tyres are in good condition and correctly inflated. If stabilizing devices are fitted, they should be employed when the machine is excavating.
- 32.4.7 When the front shovel of the 1800 backhoe loaders is being employed, the backhoe attachment shall be in its "travel" position, with the safety locking device in place.
- 32.4.8 When operating the backhoe in poor ground conditions, the stabilisers tend to sink into the surface of the ground, reducing stability. Therefore frequent checks shall be made for the stability of the machine. The loading shovel should always be lowered to the ground to stabilise the machine when the backhoe is employed.
- 32.4.9 The netting operation of the skip wagons should be carried out prior to lifting the skip to reduce the risks of working on the rear platform
- 32.4.10 If a tractor dozer is employed on clearing scrub or felling trees, it shall be provided with adequate driver protection.
- 32.4.11 When two or more scrapers are working on the same job, a minimum distance of at least 25m shall be kept between them.
- 32.4.12 In case of hydraulic breakers, hydraulic rams and hoses shall be in good working condition
- 32.4.13 While excavating care shall be taken against falling boulders, caving-in, etc., to avoid damage to men, equipment and materials. This precaution is all the more important while working close to existing railway tracks/ roads.
- 32.4.14 All wood working machines shall be fitted with suitable guards and devices such as top guard, riving knife, push stick, guards for drive belts and chains and emergency stop switch easily accessible by the operator.

### **33 PENALTY**

- 33.1.1 If any of the above clauses are not adhered, penalty shall be imposed as per relevant clause depending upon the gravity of the unsafe act and conditions.

### **34 MACHINE AND GENERAL AREA GUARDING**

- 34.1.1 The Contractor shall ensure at the construction site all motors, cogwheels, chains and

friction gearing, flywheels, shafting, dangerous and moving parts of machinery are securely fenced or legged. The fencing of dangerous part of machinery is not removed while such machinery is in motion or in use.

### **35 MANUAL LIFTING AND CARRYING OF EXCESSIVE WEIGHT**

35.1.1 The Contractor shall ensure at his construction site of a building or other construction work that no building worker lifts by hand or carries overhead or over his back or shoulders any material, article, tool or appliances exceeding in weight as said below as per Rule 38 of BOCWR, unless aided by another building worker or device.

Person	Maximum weight in kg.
Adult man	55
Adult woman	30

35.1.2 No building worker aided by other building worker shall lift or carry weight higher than or exceeding the sum of total of maximum limits set out for each building worker separately as mentioned in the table above.

### **36 SITE ELECTRICITY**

#### **36.1 Competency of Electrical Personnel**

36.1.1 The Contractor shall employ qualified and competent electrical personnel as specified in General Instruction DFCCIL/SHE/GI/001.

#### **36.2 Assessment of Power**

36.2.1 The Contractor shall assess the size and location of the electrical loads and the manner in which they vary with time during the currency of the Contract.

36.2.2 The Contractor shall elaborate as to how the total supply is to be obtained / generated. The details of the source of electricity, earthing requirement, substation / panel boards, distribution system shall be prepared and necessary approval from Engineer obtained before proceeding of the execution of the job.

36.2.3 The Contractor shall take consideration, the requirements of the sub / petty contractors' electric power supply and arrive at the capacity of main source of power supply.

36.2.4 As the sub / petty contractors' small capacity generators create more noise and safety hazard, no small capacity diesel generators shall be allowed for whatsoever the type of job to be executed under this Contract.

36.2.5 If any unsafe noise making small capacity diesel generators are found being used by sub / petty contractors, the Contractor shall only be responsible.

#### **36.3 Work on Site**

36.3.1 The Contractor shall also submit electrical single line diagram, schematic diagram and the details of the equipment for all temporary electrical installation and these diagrams together with the temporary electrical equipment shall be submitted to the Engineer for necessary approval.

#### **36.4 Strength and Capability of Electrical Equipment**

36.4.1 No electrical equipment shall be put into use where its strength and capability may be exceeded in such a way as may give rise to danger.

#### **36.5 Adverse or Hazardous Environment**

36.5.1 Electrical equipment which may reasonably foreseeably be exposed to-

- i) mechanical damage;
- ii) the effects of the weather, natural hazards, temperature or pressure;
- iii) the effects of wet, dirty, dusty or corrosive conditions; or
- iv) any flammable or explosive substance, including dusts, vapours or gases,

shall be of such construction or as necessary protected as to prevent, so far as is reasonably practicable, danger arising from such exposure.

#### **36.6 Distribution System**

36.6.1 The Contractor shall provide distribution system for control and distribution of electricity from a main AC supply of 50Hz for typical appliances,

- i) Fixed plant – 400V 3 phase
- ii) Movable plant fed via trailing cable over 3.75 kW – 400V 3 phase
- iii) Installation in site buildings – 230V single phase
- iv) Fixed flood lighting – 230V single phase
- v) Portable and hand tools – 115V single phase
- vi) Site lighting - 115V single phase
- vii) Portable hand lamps – 115V single phase

#### **36.7 Electrical Protection Circuits**

36.7.1 Precautions shall be taken, either by earthing or by other suitable means, to prevent danger arising when any conductor (other than a circuit conductor) which may reasonably foreseeable become charged as a result of either the use of a system, or a fault in a system, becomes so charged. A conductor shall be regarded as earthed when conductors of sufficient strength and current-carrying capability to discharge electrical energy to earth connect it to the general mass of earth.

36.7.2 If a circuit conductor is connected to earth or to any other reference point, nothing which might reasonably be expected to give rise to danger by breaking the electrical continuity or introducing high impedance shall be placed in that conductor unless suitable precautions are taken to prevent that danger.

36.7.3 Appropriate electrical protection shall be provided for all circuits, against over load, short circuit and earth fault current.

36.7.4 The Contractor shall provide sufficient ELCBs (maintain sensitivity 30 mA) / RCCBs for all the equipment (including Potable equipment), electrical switchboards, distribution panels etc. to prevent electrical shocks to the workers.

- 36.7.5 All protection devices shall be capable of interrupting the circuit without damage to any equipment and circuits in case of any fault may occur.
- 36.7.6 Rating of fuses and circuit breakers used for the protection of circuits should be coordinate with equipment power ratings.
- 36.7.7 Protection against lightning shall be ensured to all equipment kept in open at sites.

### **36.8 Cables**

- 36.8.1 Cables shall be selected after full consideration of the condition to which they shall be exposed and the duties for which they are required. Supply cable up to 3.3 kV shall be in accordance with BS 6346.
- 36.8.2 For supplies to mobile or transportable equipment where operating of the equipment subjects the cable to flexing, the cable shall conform to any of these codes BS 6007 / BS 6500 / BS 7375.
- 36.8.3 Flexible cords with a conductor cross sectional area smaller than 1.5 mm<sup>2</sup> shall not be used and insulated flexible cable shall conform to BS 6500 and BS 7375.
- 36.8.4 Where low voltage cables are to be used, reference shall be made to BS 7375. The following standards shall also be referred to particularly for underground cables BS 6346 and BS 6708.
- 36.8.5 Cables buried directly in the ground shall be of a type incorporating armour or metal sheath or both. Such cables shall be marked by cable covers or a suitable marking tape and be buried at a sufficient depth to avoid their being damaged by any disturbance of the ground. Cable routes shall be marked on the plans kept in the site electrical register.
- 36.8.6 Cabling passing under the walk way and across way for transport and mobile equipment shall be laid in ducts at a minimum depth of 0.6 meters.
- 36.8.7 Cables that need to cross open areas, or where span of 3m or more are involved, a catenary wire on poles or other supports shall be provided for convenient means of suspension. Minimum height shall be 6 m above ground.
- 36.8.8 Cables carrying a voltage to earth in excess of 65V other than supply for welding process shall have metal armour or sheath, which has been effectively earthed and monitored by the Contractor. In case of flexible and trailing cables such earthed metal sheath and/or armour should be in addition to the earth core in the cable and shall not be used as the protective conductor.
- 36.8.9 Armoured cables having an over-sheath of polyvinyl chloride (PVC) or an oil resisting and flame retardant compound shall be used whenever there is a risk of mechanical damage occurring.

### **36.9 Plugs, Socket-outlets and Couplers**

- 36.9.1 The Contractor shall ensure plugs, socket-outlets and couplers available in the construction site as "splash proof" type. The minimum degree of Ingress Protection should be of IP44 in accordance with BS EN 60529.
- 36.9.2 Only plugs and fittings of the weatherproof type shall be used and they should be colour coded in accordance with the Internationally recognised standards for example as detailed as follows:
  - i) 110 volts : Yellow



- ii) 240 volts : Blue
- iii) 415 volts : Red

**36.10 Connections**

- 36.10.1 Every joint and connection in a system shall be mechanically and electrically suitable for use to prevent danger. Proper cable connectors as per national/international standards shall only be used to connect cables.
- 36.10.2 No loose connections or tapped joints shall be allowed any where in the work site, office area, stores and other areas.

**36.11 Portable and Hand-held Equipment**

- 36.11.1 The Contractor shall ensure the use of double insulated or all-insulated portable electrical hand equipment may be used without earthing (i.e. two core cables), but they shall still be used only on 110V because of the risk of damage to trailing leads.

**36.12 Other Equipment**

- 36.12.1 All equipment shall have the provision for major switch/cut-off switch in the equipment itself.
- 36.12.2 All non-current carrying metal parts of electrical equipment shall be earthed through insulated cable.
- 36.12.3 Isolate exposed high-voltage (over 415 Volts) equipment, such as transformer banks, open switches and similar equipment with exposed energized parts and prevent unauthorised access.
- 36.12.4 Approved perimeter markings shall be used to isolate restricted areas from designated work areas and entryways and shall be erected before work begins and maintained for entire duration of work. Approved perimeter marking shall be installed with either red barrier tape printed with the words "DANGER—HIGH VOLTAGE" or a barrier of yellow or orange synthetic rope, approximately 1 to 1.5 meter above the floor or work surface.

**36.13 Work On or Near Live Conductors**

- 36.13.1 No person shall be engaged in any work activity on or so near any live conductor (other than one suitably covered with insulating material so as to prevent danger) that danger may arise unless-
  - i) it is unreasonable in all the circumstances for it to be dead;
  - ii) it is reasonable in all the circumstances for him to be at work on or near it while it is live and
  - iii) suitable precautions (including where necessary the provision of suitable protective equipment) are taken to prevent injury.

**36.14 Inspection and Maintenance**

- 36.14.1 All electrical equipment should be permanently numbered and a record kept of the date of issue, date of last inspection and recommended inspection period.
- 36.14.2 Fixed installations shall be inspected at least at three monthly intervals; routine maintenance being carried out in accordance with equipment manufactures recommendations.

## 37 LIGHTING

### 37.1 General

37.1.1 The Contractor shall provide sufficient site lighting, of the right type and at the right place for it to be properly effective. Lighting ought not to introduce the risk of electric shock. Therefore, 230V supplies should be used for those fittings, which are robustly installed and well out of reach e.g. flood lighting or high-pressure discharge lamps.

### 37.2 Selection of Luminaries

37.2.1 The Contractor shall select the luminaries as per the area requirement indicated below:

Type of Lighting	Area of Requirement	Luminaries
Area Lighting	Workmen and vehicles to move about in safely.	i) Shovel type: non-symmetrical ii) Symmetrical or non- symmetrical tungsten halogen
Beam flood lighting	Concentrated light over an area from a relatively great distance.	i) Portable flood light (Conical beam) ii) Wide angle flood (fan shaped beam) iii) Medium or narrow angle flood (Conical beam)
Dispersive lighting	Lighting for indoor	i) Dispersive (Mercury florescent) ii) Cargo cluster iii) Florescent trough
Walkway lighting	Lighting for stairways, ladder ways, corridors, scaffold access routes, etc.	i) Well glass unit ii) Bulkhead unit (tungsten filament) iii) Bulk head unit (Florescent)
Local lighting	Lighting on sites and fittings are generally accessible to operatives	i) PAR (Parabolic Aluminised Reflector) lamp cluster ii) Festoons (with or without shades) iii) Adjustable florescent work lamp iv) Portable flood lamp (mounted on own cable drum)

37.2.2 The Contractor shall ensure that luminaries should always be placed so that no person is required to work in their own shadow and so that the local light for one person is not a source of glare for the others. Strongly made clamps should be available for attaching luminaries to poles and other convenient supports.

37.2.3 Luminaries should be robust, resistant to corrosion and rain proof especially at the point of the cable entry.

37.2.4 The correct type of lamp for each luminary should always be used and when lamps need to be replaced it shall be in accordance with the supply voltage.

37.2.5 Lamp holders not fitted with a lamp should be capped off.

- 37.2.6 The Contractor shall take every effort to illuminate the work site as per the Employer's Requirement illustrated in General Instruction DFCCIL/SHE/GI/0011 in Attachment 9 [Reference for SHE Activities] to Clause 16 [SHE Requirements] of Specifications.

## **38 HAND TOOLS AND POWER TOOLS**

### **38.1 General**

- 38.1.1 The Contractor is wholly responsible for the safe condition of tools and equipment used by his employees and that of his sub-contractors.
- 38.1.2 Use of short / damaged hand tools shall be avoided and the Contractor shall ensure all his hand tools used at his worksite are safe to work with or stored and shall also train his employees (including his sub-contractors) for proper use thereby.
- 38.1.3 All hand tools and power tools shall be duly inspected before use for safe operation.
- 38.1.4 All hand tools and power tools shall have sufficient grip and the design specification on par with national/international standards on anthropometrics.

### **38.2 Hand Tools**

- 38.2.1 Hand tools shall include but not limited to saws, chisels, axes and hatches, hammers, hand planes, screw drivers, crow bars, nail pullers etc.
- 38.2.2 The Contractor shall ensure that,
- i) For crosscutting of hardwood, saws with larger teeth points (no. of points per inch) shall be preferred to avoid the saw jumping out of the job.
  - ii) Mushroom headed chisels shall not be used in the worksite where the fragments of the head may cause injury.
  - iii) Unless hatchet has a striking face, it shall be used as a hammer.
  - iv) Only knives of retractable blades shall be used in the worksite.
  - v) No screwdrivers shall be used for scraping, chiselling or punching holes.
  - vi) A pilot hole shall always be driven before driving a screw.
  - vii) Wherever necessary, usage of proper PPEs shall be used by his employees.

### **38.3 Power Tools**

- 38.3.1 Power tools include but not limited to drills, planes, routers, saws, jackhammers, grinders, sprayers, chipping hammers, air nozzles and drills etc.
- 38.3.2 The Contractor shall ensure that
- i) Electric tools are properly grounded or / and double insulated.
  - ii) GFCIs/ RCCBs shall be used with all portable electric tool operated especially outdoors or in wet condition.
  - iii) Before making any adjustments or changing attachments, his workers shall disconnect the tool from the power source.

- iv) When operating in confined spaces or for prolonged periods, hearing protection shall be required. The same shall also apply to working with equipment, which gives out more noise as mentioned in Clause 16 (5.3) of this contract document.
- v) Tool is held firmly and the material is properly secured before turning on the tool.
- vi) All drills shall have suitable attachments respective of the operations and powerful for ease of operation.
- vii) When any work / operation need to be performed repeatedly or continuously, tools specifically designed for that work shall be used. The same is applicable to detachable tool bit also.
- viii) Size of the drill shall be determined by the maximum opening of the chuck in case of drill bit.
- ix) Attachments such as speed reducing screwdrivers and buffers shall be provided to prevent fatigue and undue muscle strain to his workers.
- x) Stock should be clamped or otherwise secured firmly to prevent it from moving.
- xi) Workers shall never stand on the top of the ladder to drill holes in walls / ceilings, which can be hazardous, instead standing on the fourth or fifth rung shall be recommended.
- xii) Electric plane shall not be operated with loose clothing or long scarf or open jacket.
- xiii) Safety guards used on right angle head or vertical portable grinders shall cover a minimum of 1,800 of the wheel and the spindle / wheel specifications shall be checked.
- xiv) All power tools / hand tools shall have guards at their nip points.
- xv) Low profile safety chain shall be used in case of wood working machines and the saw shall run at high rpm when cutting and also correct chain tension shall be ensured to avoid "kickback".
- xvi) Leather aprons and gloves shall be used as an additional personal protection auxiliary to withstand kickback.
- xvii) Push sticks shall be provided and properly used to hold the job down on the table while the heels moves the stock forward and thus preventing kickbacks.
- xviii) Air pressure is set at a suitable level for air actuated tool or equipment being used. Before changing or adjusting pneumatic tools, air pressure shall be turned off.
- xix) Only trained employees shall use explosive actuated tools and the tool shall also be unloaded when not in use.
- xx) Usage of such explosive actuated tools shall be avoided in case of places where explosive/flammable vapours or gases may be present.

- xxi) Explosive actuated tools and their explosives shall be stored separately and be taken out and loaded only before the time of immediate use.
- xxii) Misfired cartridges of explosive actuated tools shall be placed in a container of water and be removed safely from the project.
- xxiii) No worker shall point any power operated / hand tool to any other person especially during loading / unloading.

### **39 WELDING, GOUGING AND CUTTING**

- 39.1.1 Gas cylinders in use shall be kept upright on a custom-built stand or trolley fitted with a bracket to accommodate the hoses and equipment or otherwise secured. The metal cap shall be kept in place to protect the valve when the cylinder is not connected for use.
- 39.1.2 Hose clamp or clip shall be used to connect hoses firmly in both sides of cylinders and torches.
- 39.1.3 All gas cylinders shall be fixed with pressure regulator and dial gauges
- 39.1.4 Non-return valve and Flashback arrester shall be fixed at both end of cylinder and torch.
- 39.1.5 Domestic LPG cylinders shall not be used for gas welding and cutting purpose.
- 39.1.6 DCP or CO<sub>2</sub> type Fire Extinguisher not less than 5 kg shall be fixed at or near to welding process zone in an easily accessible location. Fire extinguisher should confirm to IS 2190: 1992.
- 39.1.7 Use firewatchers if there is a possibility of ignition unobserved by the operator (e.g. on the other side of bulkheads).
- 39.1.8 Oxygen cylinders and flammable gas cylinders shall be stored separately, at least 6.6 meters (20 feet) apart or separated by a fire proof, 1.6 meters (5 feet) high partition. Flammable substances shall not be stored within 50 feet of cylinder storage areas.
- 39.1.9 Transformer used for electrical arc welding shall be fixed with ammeter and voltmeter and also fixed with separate main power switch.
- 39.1.10 Welding grounds and returns should be securely attached to the work by cable lugs, by clamps in the case of stranded conductors, or by bolts for strip conductors. The ground cable will not be attached to equipment or existing installations or apparatus.
- 39.1.11 Use a low voltage open circuit relay device if welding with alternating current in constricted or damp places.
- 39.1.12 Take precautions against the risk of increased fume hazards when welding with chrome containing fluxed consumables or high current metal inert gas (MIG) or tungsten inert gas (TIG) processes.
- 39.1.13 Avoid being in contact with water or wet floors when welding. Use duckboards or rubber protection.
- 39.1.14 All electrical installations shall meet the IS: 5571: 1997 and NFPA 70 for gas cylinder storage area and other hazardous areas.
- 39.1.15 The current for Electric arc welding shall not exceed 300 A on a hand welding operation.

## **40 DANGEROUS AND HARMFUL ENVIRONMENT**

### **40.1 As per BOCWR Rule 40**

- i) When internal combustion engines are to be used into a confined space or excavation or tunnel or any other workplace where neither natural or artificial ventilation system is inadequate to keep carbon monoxide below 50ppm, exposure of building workers shall be avoided unless suitable measures are taken and provided by the Contractor.
- ii) No worker shall be allowed into any confined space or tank or trench or excavation wherein there is given off any dust, fumes / vapours or other impurities which is likely to be injurious or offensive, explosive or poisonous or noxious or gaseous material or other harmful articles unless steps are carried out by the Contractor and certified by the responsible person to be safe.

40.2 The Contractor shall ensure that all gases, fuels and other dangerous materials and goods are stored and handed in a safe manner and in accordance with the statutory regulations and as required by the Engineer. The Contractor shall be responsible for obtaining the requisite licenses and permission to store and handle such substances.

## **41 FIRE PREVENTION, PROTECTION AND FIGHTING SYSTEM**

- 41.1.1 The Contractor shall ensure that every construction site is provided with fire protection and fire fighting, extinguishing equipment and measures in accordance with statutory regulations and as required by the Engineer. The arrangements shall be sufficient to extinguish any probable fire at construction site. An adequate water supply shall be provided with ample pressure as per the national standards.
- 41.1.2 Recharging of fire extinguishers and their proper maintenance should be ensured and as a minimum should meet Indian National Standards.
- 41.1.3 All drivers of vehicles, foreman, supervisors and managers shall be trained on operating the fire extinguishers and fire fighting equipment.
- 41.1.4 The Contractor shall also give consideration to the provision of adequate fire fighting arrangements within the underground and tunnelling operations including the provision of Fire Service compatible hose connections and emergency lighting.
- 41.1.5 All lifting appliances' driver cabin should be provided with a suitable portable fire extinguisher.
- 41.1.6 Combustible scrap and other construction debris should be disposed off site on a regular basis. If scrap is to be burnt on site subject to consent of the Engineer, the burning site should be specified and located at a distance no less than 12 metres from any construction work or any other combustible material.
- 41.1.7 If, in the Engineer's opinion, the use of naked lights may cause a fire hazard, the Contractor shall take such additional precautions and provide such additional fire fighting equipment as the Engineer considers necessary. The term "naked light" shall be deemed to include electric arcs and oxyacetylene or other flames used in welding or cutting metals.
- 41.1.8 Every fire, including those extinguished by the Contractor's Personnel, shall be

reported to the Engineer.

- 41.1.9 A Fire Evacuation Plan shall be prepared and issued. Mock drills should be held on a regular basis to ensure the effectiveness of the arrangements and as a part of the plan, the telephone number of the local fire brigade should be prominently displayed near each telephone on site.

## **42 CORROSIVE SUBSTANCES**

- 42.1.1 As per BOCWR Rule 44, corrosive substances including alkalis and acids shall be stored and used by a person dealing with such substances at a building / construction site in a manner that it does not endanger the building /construction worker and suitable PPE shall be provided by the Contractor to the workers during such handling and work. In case of spillage of such substances on the worker, the Contractor shall take immediate remedial measures.

## **43 DEMOLITION**

- 43.1.1 The Contractor shall ensure that
- i) all demolition works be carried out in a controlled manner under the management of experienced and competent supervision.
  - ii) the concerned department of the Government or local authority be informed and permission obtained wherever required. Media shall also be informed regarding this concern.
  - iii) all glass or similar materials or articles in exterior openings are removed before commencing any demolition work and all water, steam, electric, gas and other similar supply lines are put-off and such lines so located or capped with substantial coverings so as to protect it from damage and to afford safety to the building workers and public.
  - iv) examine the walls of all structures adjacent to the structure to be demolished to determine thickness, method of support to such adjacent structures.
  - v) no demolishing work be performed if the adjacent structure seems to be unsafe unless and until remedial measures life sheet piling, shoring, bracing or similar means be ensured for safety and stability for adjacent structure from collapsing.
  - vi) debris / bricks and other materials or articles shall be removed by means of
    - a) chutes
    - b) buckets or hoists
    - c) through openings through floors or
    - d) any other safe means as consented by the Engineer
  - vii) no person other than building workers or other persons essential to the operation of demolition work shall be permitted to enter a zone of demolition and the area be provided with substantial barricades.

## **44 EXCAVATION**

### **44.1 Excavation**

44.1.1 The Contractor shall ensure

- i) where any construction / building worker engaged in excavation is exposed to hazard of falling or sliding material or article from any bank or side of such excavation which is more than 1.5 m above his footing, such worker shall be protected by adequate piling and bracing against such bank or side.
- ii) where banks of an excavation are undercut, adequate shoring is provided to support the material or article overhanging such bank.
- iii) excavated material is not stored at least 0.65 m from the edge of an open excavation or trench and banks of such excavation or trench are stripped of loose rocks and the banks of such excavation or trench are stripped of loose rocks and other materials which may slide, roll or fall upon a construction building worker working below such bank
- iv) metal ladders and staircases or ramps are provided, as the case may be, for safe access to and egress from excavation where, the depth of such excavation exceeds 1.5 m and such ladders, staircases or ramps comply with the IS 3696 Part 1&2 and other relevant national standards.
- v) trench and excavation is protected against falling on a person by suitable measures if the depth of such trench or excavation exceeds 1.5m and such protection is an improved protection in accordance with the design and drawing of a professional engineer, where such depth exceeds 4.0m.

### **44.2 Warning Signs and Notices**

44.2.1 The Contractor shall ensure that

- i) suitable warning signs or notices, required for the safety of building / construction workers carrying out the work of an excavation or tunnelling, shall be displayed or erected at conspicuous places in Hindi and in a language understood by majority of such workers at such building such excavation or tunnelling work
- ii) such warning signs and notices with regard to compressed air working shall include
  - a) the danger involved in such compressed air work
  - b) fire and explosion hazard
  - c) the emergency procedures for rescue from such danger or hazards.

## **45 WORK PERMIT SYSTEM**

45.1.1 The Contractor shall develop a work permit system, which is a formal written system used to control certain types of work that are potentially hazardous. A work permit is a document, which specifies the work to be done and the precautions to be taken. Work



Permits form an essential part of safe systems of work for many construction activities. They allow work to start only after safe procedures have been defined and they provide a clear record that all foreseeable hazards have been considered. Permits to Work are usually required in high-risk areas as identified by the Risk Assessments.

45.1.2 A permit is needed when construction work can only be carried out if normal safeguards are dropped or when new hazards are introduced by the work. Examples of high-risk activities include but are not limited to:

- i) Entry into confined spaces
- ii) Work in close proximity to overhead power lines and telecommunication cables.
- iii) Hot work.
- iv) To dig-where underground services may be located.
- v) Work with heavy moving machinery.
- vi) Working on electrical equipment
- vii) Work with radioactive isotopes.
- viii) Heavy lifting operations and lifting operations close to live power line

45.1.3 The permit-to-work system should be fully documented, laying down:

- i) How the system works;
- ii) The jobs it is to be used for;
- iii) The responsibilities and training of those involved and
- iv) How to check its operation;

45.1.4 The Permit-to-Work system shall be submitted to the Engineer for review before application.

45.1.5 A Work Permit authorisation form shall be completed with the maximum duration period not exceeding 12 hours.

45.1.6 A copy of each Permit To Work shall be displayed, during its validity, in a conspicuous location in close proximity to the actual works location to which it applies.

## **46 TRAFFIC MANAGEMENT**

### **46.1 General**

46.1.1 The basic objective of the following guiding principles is to lay down procedures to be adopted by the Contractor to ensure the safe and efficient movement of traffic and also to ensure the safety of workmen in the all Work Areas.

46.1.2 The guiding principles to be adopted for safety in construction zone are to

- i) Warn the road user clearly and sufficiently in advance.
- ii) Provide safe and clearly marked lanes and diversions for guiding road users.

- iii) Provide safe and clearly marked buffer and work zones
- iv) Provide adequate traffic marshals to regulate the movement of traffic
- v) Provide adequate measures that control driver behaviour through construction zones.

#### **46.2 Legal Permission**

- 46.2.1 In all cases, the Contractor shall employ proper precautions. Wherever operations undertaken are likely to interfere with public traffic, specific Traffic Management Plans shall be drawn up and implemented by the Contractor in consultation with the approval of local police authorities and/or the concerned metropolitan/civil authorities as the case may be.
- 46.2.2 Such traffic management plans shall include provision for traffic diversion and selection of alternative routes for transport of equipment. If necessary, the Contractor shall carry out road widening before commencement of works to accommodate the extra load
- 46.2.3 The primary traffic control devices used in work zones shall include signs, delineators, barricades, cones, pylons, pavement markings and flashing lights.
- 46.2.4 The road construction and maintenance signs which fall into the same three major categories as do other traffic signs, that are Regulatory Signs, Warning Signs and Direction (or guidelines) Signs shall only be used. The IRC: 67 (Code of Practice for Road Signs) provide a list of traffic signs. The size, colours and placement of sign shall confirm to IRC: 67.

#### **46.3 Regulatory Signs**

- 46.3.1 Regulatory signs impose legal restriction on all traffic. It is essential, therefore, that they are used only after consulting the local police and traffic authorities.

#### **46.4 Warning Signs**

- 46.4.1 Warning signs in the traffic control zone shall be utilised to warn the drivers of specific hazards that may be encountered.
- 46.4.2 The Contractor shall place detour signage at strategic locations and install appropriate warning signs. In order to minimize disruption of access to residences and business, the Contractor shall maintain at least one entrance to a property where multiple entrances exist.
- 46.4.3 A warning sign shall be installed on all secondary road which merge with the primary road where the construction work is in progress at sufficient distance before it merges with the primary road so as to alert the road users regarding the 'Work in Progress'. The Contractor shall develop the design and obtain the Engineer's consent.
- 46.4.4 Materials hanging over / protruded from the chassis / body of any vehicle especially during material handling shall be indicated by red indicator (red light/flag) to indicate the caution to the road users.

#### **46.5 Delineators**

- 46.5.1 The delineators are the elements of a total system of traffic control and have two distinct purposes:
  - i) To delineate and guide the driver to and along a safe path

- ii) As a taper to move traffic from one lane to another.
- 46.5.2 These channelising devices such as cones, traffic cylinders, tapes and drums shall be placed in or adjacent to the roadway to control the flow of traffic. These should normally be retro-reflectors complying to IRC: 79 - Recommended Practice for Road Delineators.
- 46.5.3 Traffic cones and cylinders: traffic cones of 500mm, 750mm and 1,000mm high and 300mm to 500mm in diameter or in square shape at base and are often made of plastic or rubber and normally have retro-reflectorised red and white band shall be used wherever required.
- 46.5.4 Drums: drums about 800mm to 1000mm high and 300mm in diameter can be used either as channelising or warning devices. These are highly visible, give the appearance of being formidable objects and therefore command the respect of drivers.
- 46.5.5 Barricades: full height fence, barriers, barricades etc. shall be erected around the site in order to prevent the working area from the risk of accidents due to speedy vehicular movement. Same the way barricades protect the road users from the danger due to construction equipment and other temporary structures.
- 46.5.6 The structure dimension of the barricade, material and composition, its colour scheme, DFCCIL logo and other details shall be in accordance with the Employer's Requirements for Temporary Works.
- 46.5.7 All barricades shall be erected as per the approved design, numbered, painted and maintained in good condition and also Barricade in-charge maintains a barricade register in site.
- 46.5.8 All barricades shall be conspicuously seen in the dark/night time by the road users so that no vehicle hits the barricade. Conspicuity shall be ensured by affixing retro reflective stripes of required size and shape at appropriate angle at the bottom and middle portion of the barricade at a minimum gap of 1000mm. In addition minimum one red light or red light blinker should be placed at the top of each barricade.
- 46.5.9 Vehicle and Operator Licenses: the Contractor shall ensure that all his construction vehicles plying on public roads (like dump trucks, trailers, etc.) have proper license to ply on public roads from the State Transport Authority. Drivers holding proper valid license as per the requirements of Motor Vehicles Act shall drive these vehicles
- 46.5.10 No obstruction to traffic: the Contractor shall not undertake loading and unloading at carriageways obstructing the free flow of vehicular traffic and encroachment of existing roads by the Contractor applying the excuse of work execution.
- 46.5.11 Tow away vehicle: the Contractor shall make arrangements keeping tow away van / manpower to tow away any breakdown vehicle in the traffic flow without loosing any time at his cost.
- 46.5.12 Cleaning of roads: the Contractor shall ensure the cleanliness of roads and footpaths by deploying proper manpower for the same. The Contractor shall have to ensure proper brooming, cleaning washing of roads and footpaths on all the time throughout the entire stretch till the currency of the contract including disposal of sweepings.

## **47 WORK ADJACENT TO RAILWAYS**

### **47.1 Protection of Live Railways**

- 47.1.1 The Contractor shall design to install the temporary fencing / barricades for protection

of the existing Indian Railway (IR) lines where the construction activities of all Works adjacent to the line are taking place. The fencing / barricades shall be installed as indicated in the Reference Drawings and the fencing may be movable and reusable whereas it is stable enough not to lean and infringe the structure gauge of the IR lines. The fencing pole / barricades shall be colored to enhance visual precautionary effects. The Contractor shall submit the design of the temporary fencing / barricades to the Engineer for consent.

47.1.2 Whenever work is to be conducted in close proximity to the live railways, the following measures shall need to be addressed:

- i) The rules provided in the Railway's manual shall be followed.
- ii) No persons are allowed to encroach onto the railway unless specific authority has been given by the owner.
- iii) Adequate protection in accordance with the railway owner's requirements shall be followed. (Provision of Block Inspectors, Flagmen and Lookouts)
- iv) All persons shall wear high visibility clothing at all times.
- v) Any induction training requirements of the railways shall be strictly observed.
- vi) Special care shall be taken to ensure safety of the travelling public, safety of existing railway and other structures located nearby, etc.

## **47.2 Securement of Train Operation**

47.2.1 Where the work to be executed is in proximity of the running railway track, the Contractor shall be required to observe all precautions and carryout all works that may be necessary to ensure the safety of the running track/trains etc. without imposition of any speed restriction thereon as may be directed by the Engineer. The Contractor shall ensure that the materials are not stacked close to the railway track, which may endanger the safety of trains and workmen.

## **48 BATCHING PLANT / CASTING YARD**

48.1.1 The batching plant / casting yard shall be effectively planned for smooth flow of unloading and stacking the aggregates reinforcements and cement, batching plant, transport of concrete, casting and curing of the segment, stacking the segment and loading the segments to the trucks. As far as possible the conflicts should be avoided.

48.1.2 The batching plant/casting yard shall be barricaded and made as a compulsory PPE zone

48.1.3 If in case of material unloading area is not maintainable as PPE zone, the same shall be segregated properly and made as a non-PPE zone with appropriate barrications.

48.1.4 Electrical system shall also be suitably planned so that location of diesel generator, if any, location of DBs, routing of cables and positioning of area lighting poles/masts does not infringe on any other utility and pose danger.

48.1.5 Drainage shall be effectively provided and waste water shall be disposed after proper treatment

- 48.1.6 Time office, canteen, drinking water, toilet and rest place shall be suitably located for the easy access to workers. All the facilities shall be properly cleaned and maintained during the entire period of operation.
- 48.1.7 Manual handling of cement shall be avoided to a larger extent. Whenever it is absolutely necessary, the workmen shall be given full body protection, hand protection and respiratory protection as a basic measure of ensuring better health.
- 48.1.8 The PPEs provided to cement handling workmen shall conform to international standards.
- 48.1.9 Access roads and internal site roads shall be well laid and maintained properly at all time.

#### **49 OTHER WORKS TO BE SCRUTINIZED**

Other Works including, but not be limited to, Works in the Site (the ROW), the Works in the Borrow Pit, Works in the Quarry and Works on road shall be included to be scrutinised with respect to the accident prevention.

If blasting is anticipated in excavation in rock, preventive measures against accidents and protective measures against environmental/ social impacts shall be of paramount importance.

The Contractor shall include all those items as well as aforementioned work elements to formulate the preventive and protective measures taking into account envisaged conditions, situations and particular activities of the Works which may induce accidents or hazard to environment and/or society.

#### **50 PERSONAL PROTECTIVE EQUIPMENT (PPEs)**

- 50.1.1 The Contractor shall provide required PPEs to workmen to protect against safety and / or health hazards. Primarily PPEs are required for the following protection
  - i) Head Protection (Safety helmets)
  - ii) Foot Protection (Safety footwear, Gumboot, etc.)
  - iii) Body Protection (High visibility clothing (waistcoat/jacket), Apron, etc.)
  - iv) Personal fall protection (Full body harness, Rope-grip fall arrester, etc.)
  - v) Eye Protection (Goggles, Welders glasses, etc.)
  - vi) Hand Protection (Gloves, Finger coats, etc.)
  - vii) Respiratory Protection. (Nose mask, SCBAs, etc.)
  - viii) Hearing Protection (Ear plugs, Ear muffs, etc.)
- 50.1.2 The PPEs and safety appliances provided by the Contractor shall be of the standard as prescribed by Bureau of Indian Standards (BIS). If materials conforming to BIS standards are not available, the Contractor as approved by the Engineer shall procure PPE and safety appliances.
- 50.1.3 The Contractor shall provide the PPEs which the Contractor deems necessary including, but not be limited to, safety helmets, safety shoes to all the Contractor's Employees including workmen (including those of its sub-contractors). When and Where the Contractor thinks that he needs to provide the Contractor's Employees

including workmen (including those of its sub-contractors) with high visibility clothing as per the following requirement.

- i) Hi-visibility jacket covering upper body and meeting the following requirements as per BS EN 471:1994:
- ii) Background in fluorescent orange-red in colour
- iii) Jackets with full-length sleeves with two bands of retro reflective material, which shall be placed at the same height on the garment as those of the torso. The upper band shall encircle the upper part of the sleeves between the elbow and the shoulder; the bottom of the lower band shall not be less than 5cm from the bottom of the sleeve.
- iv) Two vertical green strips of 5cm wide on front side, covering the torso at least 500 cm<sup>2</sup>
- v) Two diagonal strips of 5 cm wide on back in an 'X' pattern covering at least 570cm<sup>2</sup>
- vi) Horizontal strips not less than 5cm wide running around the bottom of the vertical strip in front and 'X' pattern at back.
- vii) The bottom strip shall be at a distance of 5cm from the bottom of the vest.
- viii) Strips shall be retro reflective and fluorescent.

50.1.4 Colour coding for helmets

Safety Helmet Colour Code (Every Helmet should have the LOGO* affixed /painted)	Person to use
White	DFCCIL staff
Grey	All Designers, Architect, Consultants, etc.
Violet	Main Contractors (Engineers / Supervisors)
Blue	All Sub-contractors (Engineers / Supervisors)
Red	Electricians (Both Contractor and Sub-contractor)
Green	Safety Professionals (Both Contractor and Sub-contractor)
Orange	Security Guards / Traffic marshals
Yellow	All workmen
White (with "VISITOR" sticker)	Visitors

Note: LOGO\*

- i) Logo shall have its outer dimension 2"X2" and shall be conspicuous
- ii) Logo shall be either painted or affixed
- iii) No words shall come either on Top / Bottom of Logo

Logo of the corresponding main contracting company for their employees and sub-contracting company for their employees shall only be used.

- 50.1.5 In addition to the above any other PPEs required for any specific jobs like, welding and cutting, working at height, tunnelling etc. shall also be provided to all workmen and also ensure that all workmen use the PPEs properly while on the job.
- 50.1.6 The Contactor shall not pay any cash amount in lieu of PPEs to the workers/sub-contractors and expect them to buy and use during work.
- 50.1.7 The Contactor shall at all time maintain a minimum of 10% spare PPEs and safety appliances and properly record and show to the Engineer during the inspections.
- 50.1.8 It is always the duty of the Contactor to provide required PPEs for all visitors. Towards this required quantity of PPEs shall be kept always at the security post.
- 50.1.9 The Contractor shall ensure that safety equipment and protective clothing is available and used on the site at all material times and those measures for the effective enforcement of proper utilisation and necessary replacement of such equipment and clothing shall be incorporated into the Site SHE Plan.

## **51 VISITORS TO SITE**

- 51.1.1 No visitor is allowed to enter the site without the permission of the Engineer. All authorised visitors should report at the site office. Contractor shall provide visitor's helmet (White helmet with visitor sticker) and other PPEs like safety shoe, reflective jacket, respiratory protection etc. as per requirement of the site.
- 51.1.2 All visitors shall be accompanied at all times by a responsible member of the site personnel.
- 51.1.3 The Contactor shall be fully responsible for all visitors' safety and health within the site.

## **Part V: Occupational Health and Welfare**

### **52 PHYSICAL FITNESS OF WORKMEN**

- 52.1.1 The Contractor shall ensure that his employees/workmen subject themselves to such medical examination as required under the law or under the contract provision and keep a record of the same.
- 52.1.2 The Contractor shall not permit any employee/workmen to enter the work area under the influence of alcohol or any drugs.

### **53 MEDICAL FACILITIES**

#### **53.1 Medical Examination**

- 53.1.1 The Contractor shall arrange a medical examination of all his employees including his sub-contractor employees employed as drivers, operators of lifting appliances and transport equipment before employing, after illness or injury, if it appears that the illness or injury might have affected his fitness and, thereafter, once in every two years up to the age of 40 and once in a year, thereafter.
- 53.1.2 The Contractor shall maintain the confidential records of medical examination or the physician authorized by the Engineer.
- 53.1.3 No building or other construction worker is charged for the medical examination and the cost of such examination is borne by the Contractor employing such worker.
- 53.1.4 The medical examination shall include a full medical and occupational health history, with a clinical examination with particular reference to
- i) General Physique;
  - ii) Vision: - Total visual performance using standard orthorator like Titmus Vision Tester should be estimated and suitability for placement ascertained in accordance with the prescribed job standards.
  - iii) Hearing: - Persons with normal must be able to hear a forced whisper at twenty-four feet. Persons using hearing aids must be able to hear a warning shout under noisy working conditions.
  - iv) Breathing: - Peak flow rate using standard peak flow meter and the average peak flow rate determined out of these readings of the test performed. The results recorded at pre-placement medical examination could be used as a standard for the same individual at the same altitude for reference during subsequent examination.
  - v) Upper Limbs: - Adequate arm function and grip
  - vi) Spine: - Adequately flexible for the job concerned.
  - vii) Lower Limbs: - Adequate leg and foot concerned.
  - viii) General: - Mental alertness and stability with good eye, hand and foot coordination
  - ix) Any other tests which the examining doctor considers necessary
- 53.1.5 If the Contractor fails to get the medical examination conducted as mentioned above,



the Engineer will have the right to get the same conducted through an agency with intimation to the Contractor and deduct the cost and overhead charges from his dues.

### **53.2 Occupational Health Centre (First Aid Station)**

53.2.1 The Contractor shall provide at a construction site an occupational health centre (OHC) as a first aid station and maintain it in good order in terms of Rule 225 (b) of BOCWR. At least one The OHC shall be provided to serve a length of about 30 km along the alignment and shall have:

- i) Minimum floor area of 15 square metres, adequately illuminated and ventilated;
- ii) Two air-conditioned rooms with smooth walls and intern service;
- iii) Adequate and necessary equipment for day-to-day requirement and to manage any medical emergency.

53.2.2 The Contractor shall appoint one construction medical officer as in charge of the OHC where the total number of employees is up to one thousand and one additional construction medical officer for every additional one thousand employees or part thereof. The qualifications (Schedule XI of BOCWR) of such construction medical officer shall be:

- i) MBBS degree from a medical institute recognised by the Medical Council of India and;
- ii) Diploma in industrial health or equivalent post-graduate certificate of training in industrial health;

53.2.3 A medical officer having more than three(3) years of experience in policy, execution, advice and safety and health of workers employed in mines, ports and docks, factories, building and other construction work, may be considered without the qualification mentioned at (ii) above.

53.2.4 The Contractor shall appoint appropriate full-time staff including one nurse, one dresser-cum-compounder, one sweeper-cum-ward boy with each construction medical officer.

53.2.5 The Contractor shall communicate the complete particulars including name, qualification and experience of the construction medical officer, to the inspector having jurisdiction under BOCWR.

### **53.3 Ambulance Room, Ambulance Van and Stretchers**

53.3.1 At Construction sites where five hundred (500) or fewer workers are employed, the Contractor shall provide an ambulance room in terms of Rule 226 of BOCWR. Alternatively the Contractor shall make an arrangement with a nearby hospital for providing suitable ambulance rooms. Such ambulance rooms shall have a qualified nurse in charge and its services are available to all workers during working hours.

53.3.2 In a Construction site where five hundred (500) or more workers are employed, the Contractor shall provide an ambulance room with a suitably qualified Construction Medical Officer in charge, provided with an effective communication system.

53.3.3 An ambulance room shall be equipped at least with the articles listed in Schedule IV, BOCWR (ref: Rule 226).

53.3.4 The Contractor shall provide an ambulance van at all construction sites or make an arrangement with a nearby hospital for providing such an ambulance van for prompt transportation of workers who meet with serious accident or who are sick. It is the Contractor's responsibility to ensure that all such ambulances are maintained in good repair and equipped with standard facilities specified in Schedule V of BOCWR.

53.3.5 The Contractor shall provide a sufficient number of stretchers at each construction site for use in an emergency.

#### **53.4 First-aid Boxes and Emergency Care**

53.4.1 The Contractor shall ensure at a construction site one first-aid box for 100 workers provided and maintained for providing first-aid to the building workers and other construction workers. Every first-aid box shall be distinctly marked "First-aid" and equipped with the articles specified in Schedule III of BOCWR.

53.4.2 At all construction sites, the Contractor shall provide essential life-saving aids and appliances under the supervision of a construction medical officer, where he may be required to handle: Such life saving aids shall be provided to any worker who meets with an accident, before and during his transportation to a hospital and until he is attended by a doctor in such hospital.

53.4.3 The Contractor shall also provide other equipment or facilities that may be required for emergency care or treatment of a worker arising from local conditions and specific construction processes.

#### **53.5 HIV/ AIDS Prevention and Control**

53.5.1 The Contractor shall adopt the Employer's "Workplace Policy on HIV / AIDS Prevention and Control for Workers Engaged by Contractors" and implement it. A copy of the policy is given in Attachment 8 [Workplace Policy on HIV/AIDS Prevention & Control] to Clause 16 [SHE Requirements] of Specifications.

53.5.2 The Contractor shall prepare and submit a manual for HIV/AIDS prevention and control for his workers in terms of the aforesaid Employer's Policy within 112 days of the date of notification of the Contract.

#### **53.6 Prevention of Mosquito Breeding**

53.6.1 Measures shall be taken to prevent mosquito breeding at site. The measures to be taken shall include:

- i) Empty cans, oil drums, packing and other receptacles, which may retain water shall be deposited at a central collection point and shall be removed from the site regularly.
- ii) Still waters shall be treated at least once every week with oil in order to prevent mosquito breeding.
- iii) Contractor's equipment and other items on the site, which may retain water, shall be stored, covered or treated in such a manner that water could not be retained.
- iv) Water storage tanks shall be provided.

53.6.2 Posters in local language, Hindi and English, which draw attention to the dangers of permitting mosquito breeding, shall be displayed prominently on the site.

53.6.3 The Contactor at periodic interval shall arrange to prevent mosquito breeding by fumigation / spraying of insecticides. Most effective insecticides shall include SOLFAC WP 10 or Baytex, The Ideal Larvicide etc.

### **53.7 Alcohol, Smoking and Drugs**

53.7.1 The Contactor shall ensure at all times that no employee is working under the influence of alcohol / drugs which are punishable under Govt. regulations.

53.7.2 Smoking at public worksites by any employee is also prohibited as per Govt. regulations. The Contractor shall comply with the legal provisions in this regard, such as, Prohibition of Smoking in Public places Rules, 2008. He shall be solely responsible for any penalty or punitive action by the government authorities on account of violations of the provisions contained in these rules by him or his representatives or his employees or his sub-contractors. Requisite notice boards, posters, etc., shall be put by him, as per the Rules.

## **54 OCCUPATIONAL NOISE**

### **54.1 General**

54.1.1 The Contractor shall comply with the codes, regulations and standards with regard to noise pollution and control as notified and amended by Central Government and State Governments from time to time including but not necessarily limited to:

- i) Rule 34 and Schedule VI of the Building and Other Construction Workers (Regulation of Employment of Service) Central Rules of 1998;
- ii) Noise Pollution (Regulation and Control) Rules, 2000;
- iii) Environment (Protection) Act, 1986;
- iv) Environment (Protection) Amendment Rules, 2000;
- v) Central Motor Vehicles Rules, 1989;
- vi) Notification on Control of Noise from DG Sets, 2002

54.1.2 The Contractor shall comply at all times with any specific requirements of these and any other relevant statutes, including prescribed noise limits and standards as follows:

- i) Permissible Exposure Levels of Impulse or Impact Noise for Work Zone Area [as per Model Rules of Factories Act, 1948]
- ii) Permissible Exposure in Case of Continuous Noise for Work Zone Area [as per Model Rules of Factories Act, 1948].

54.1.3 The Contractor shall consider noise level reduction in his design, planning and execution of the Works and provide demonstrable evidence of the same on Engineer's request. The Contractor shall, at his own expense, take all appropriate measures to ensure that work carried out by the Contractor and by his sub-contractors, whether on or off the Site, will not cause any unnecessary or excessive noise.

54.1.4 Without prejudice to the generality of the foregoing, noise level reduction measures shall include the following:

- i) The Contractor shall ensure that all powered mechanical equipment used in the Works shall be effectively sound reduced using the most

modern techniques available including but not limited to silencers and mufflers.

- ii) The Contractor shall construct acoustic screens or enclosures around any parts of the Works from which excessive noise may be generated.

**54.2 Control Measures**

54.2.1 Protection against the effects of occupational noise exposure shall be provided when the sound levels exceed the threshold values.

54.2.2 The Contractor shall take adequate measures to protect the workers against the harmful effects of excessive noise at all work sites including the continuous sound level exceeding those specified in Schedule VI "Permissible Exposure in Cases of Continuous Noise" of BOCWR(see table below).

Duration per day, Hours	Sound level (slow Response)
8	90
6	92
4	95
3	97
2	100
1 ½	102
1	105
½	110
¼ or less	115

54.2.3 If such controls fail to reduce sound levels below the levels of the table, personal protective equipment shall be provided and used to reduce sound levels below the levels of the table.

54.2.4 As a minimum, the Contractor shall provide ear protection to workers who are continuously exposed to high sound levels. Effectiveness of ear protectors shall be checked at a regular interval. Audiometry of the workers exposed to high noise level shall be conducted from time to time.

54.2.5 When the daily noise exposure is composed of two or more periods of noise exposure of different levels, their combined effect should be considered, rather than the individual effect of each. Exposure to different levels for various periods of time shall be considered and computed accordingly. The basis of the calculations and the formula adopted shall have the prior consent of the Engineer.

**55 VENTILATION AND ILLUMINATION**

**55.1 Ventilation**

55.1.1 The Contractor shall ensure at a construction site of a building or other construction

work that all working areas in a free tunnel are provided with ventilation system as approved by the DG and the fresh air supply in such tunnel is not less than 6m<sup>3</sup>/min for each building worker employed underground in such tunnel and the free air flow movement inside such tunnel is not less than 9m<sup>3</sup>/min.

55.1.2 The oxygen level shall not be less than 19.5% in the working environment.

## **55.2 Illumination**

55.2.1 The Contactor shall take every effort to illuminate the work site as per the Employer's Requirement illustrated in General Instruction DFCCIL/SHE/GI/0011 of Attachment 9 [Reference for SHE Activities] to Clause 16 [SHE Requirements] of Specifications.

55.2.2 The Contactor shall conduct a monthly illumination monitoring by a lux meter for all the locations and the report shall be sent to the Engineer within 7th of the next month and the same shall be reviewed during the monthly SHE Committee meeting.

## **56 RADIATION**

56.1.1 The use of radioactive substances and radiating apparatus shall comply with the Government regulatory requirements and all subsidiary legislations.

56.1.2 Operations involving ionising radiation shall only be carried out after having been reviewed without objection by the Engineer and shall be carried out in accordance with a method statement.

56.1.3 Each area containing irradiated apparatus shall have warning notices and barriers, as required by the regulations, conspicuously posted at or near the area.

56.1.4 Radioactive substances shall be stored, used or disposed off, strictly in accordance with the Government Enactments.

56.1.5 The Contactor shall ensure that all site personnel and members of the public are not exposed to radiation.

## **57 WELFARE MEASURES FOR WORKERS**

### **57.1 Latrine and Urinal Accommodation**

57.1.1 Latrine and urinals shall be provided as per Section 33 of BOCWA and maintained as per Rule 243 of BOCWR and shall also comply with the requirements of public health authorities.

57.1.2 When women are employed, separate latrine and urinals accommodation shall be provided.

### **57.2 Moving Sites**

57.2.1 In case of works like track laying, the zone of work is constantly moving at elevated level or at underground level. In such cases mobile toilets with proper facility to drain the sullage shall be provided at reasonably accessible distance.

57.2.2 In case the Contactor fail to provide required number of urinals and latrines or fail to maintain it as per the requirements of Public Health laws, the Engineer shall have the right to provide/maintain through renowned external agencies at the cost of the Contactor.

### **57.3 Canteen**

57.3.1 In every workplace wherein not less than 250 workers the Contractor shall provide an adequate canteen conforming to Section 37 of BOCWA, Rule 244 of BOCWR and as stipulated in Rule 247 of BOCWR. The charges for food stuff shall be based on 'no profit no loss' basis. The price list of all items shall be conspicuously displayed in such canteen.

### **57.4 Serving of Tea and Snacks at the Workplace**

57.4.1 In terms of Rule 246 of BOCWR, at a building or other construction work where a workplace is situated at a distance of more than 200 m from the canteen provided under Rule 244(1) of BOCWR, the Contractor shall make suitable arrangement for serving tea and light refreshment to such building works at such place.

### **57.5 Drinking Water**

57.5.1 As per Section 32 of BOCWA the Contractor shall make in every worksite, effective arrangements to provide sufficient supply of wholesome drinking water. Quality of the drinking water shall conform to the requirements of national standards on Public Health laws.

57.5.2 While locating these drinking water facilities due care shall be taken so that these are easily accessible within a distance of 200m from the place of work for all workers at all location of work sites. All such points shall be legible marked "Drinking Water" in a language understood by a majority of the workmen employed.

### **57.6 Creches**

57.6.1 In every workplace where in more than 50 female workers are ordinarily employed, there shall be provided and maintained a suitable room for use of children under age of 6 yrs, conforming to the provisions of Section 35 of BOCWA.

### **57.7 Labour Accommodation Camps**

57.7.1 Where workers are based some distance from their normal place of residence, the Contractor shall provide them with suitable and safe accommodation free of charge and shall take all necessary precautions to protect their health and welfare. The accommodation shall conform to the requirements of Section 34 of BOCWA and include but not be limited to the further measures specified hereunder.

57.7.2 All accommodation camps shall be provided at all times with a sufficient supply of clean drinking water (of potable quality according to national legal standards), in suitable and easily accessible locations.

- i) The quality of drinking water shall be tested once a fortnight as prescribed in IS 1050:1991 and immediate remedial action shall be taken if quality falls below the standard. Test results shall be provided to the Engineer at least monthly.
- ii) Storage tanks for potable water shall be located at least 1 m above ground level and any boreholes or wells shall be 30 m or more from any toilet, drain or other potential source of pollution.
- iii) Any wells shall be securely covered and provided with a trap door for inspection purposes, which is water and dust-proof and kept locked at all times, except when pump inspections and maintenance are performed.

- iv) All wells shall be provided with suitable pumps, which shall be inspected and cleaned periodically according to manufacturers' specifications and repaired or replaced immediately that any malfunction is detected.
- 57.7.3 The Contractor shall provide all accommodation camps with clean and properly equipped and staffed kitchen and canteen facilities to supply meals for workers.
- 57.7.4 The Contractor shall provide sufficient toilet and bathroom facilities for the numbers of workers accommodated in each camp. Separate accommodation and toilet/bathroom facilities shall be provided for men and women and all facilities shall be kept in full working order at all times and cleaned and re-equipped daily.
- 57.7.5 The Contractor shall provide a laundry facility for the workers at the Labour Camps.

## **Part VI: Environmental and Social Management**

### **58 LEGISLATION**

58.1.1 The Contractor shall comply at all times with all relevant national and state legislation regarding environmental and social protection, pollution prevention and control, waste management and other relevant environmental and social matters, including but not necessarily limited to the following:

- The Environment (Protection) Act 1986 and Environment (Protection) Amendment Rules 2002 (amended 2003, 2004, 2005, 2006, 2007 and 2008);
- The Indian Wildlife (Protection) Act, 1972;
- The Forest (Conservation) Act, 1980 & rules there under;
- The Noise Pollution (Regulation and Control) Rules 2000;
- The Air (Prevention and Control of Pollution) Act 1981 (amended 1987);
- The Water (Prevention and Control of Pollution) Act 1974 (amended 1988);
- The Ground Water (Regulation, Development and Management) Rules 2007;
- The Municipal Solid Waste (Management and Handling) Rules 2000;
- The Hazardous Waste (Management, Handling and trans-boundary Movement) Rules, 2008 and its amendment;
- The Manufacture, Storage and Import of Hazardous Chemicals (Amendment) Rules 2000;
- The Bio-medical Waste (Management and Handling) Rules 1998;
- The Batteries (Management and Handling) Rules 2001.

58.1.2 Some guidance on the applicability and demands of these statutes is given where relevant below. This is not intended to be definitive and it is the Contractor's responsibility to obtain detailed guidance from the appropriate government competent authorities regarding the specific requirements of all applicable legislation.

58.1.3 It is also the Contractor's responsibility to obtain all official approvals, consents or other authorizations as may be necessary in order to comply with the relevant statutes and to pay all related fees and other costs. The Contractor shall obtain all such authorizations in a timely manner and submit to the Engineer for checking well before commencement of any related construction activity.

58.1.4 The Contractor shall comply with all legislative requirements and any additional conditions imposed by the competent authorities via consent conditions or any other mechanism, throughout the entire construction period.

### **59 SITE PREPARATION**

#### **59.1 Preservation of Trees**

59.1.1 The Contractor shall not cut any tree within or outside the work site without the explicit written approval of the Engineer and the government Forest Department.



59.1.2 The Contractor shall design all the Temporary and Permanent Works in such a way as to retain trees to the extent possible, without impeding operational requirements and safety.

59.1.3 Before construction begins, the Contractor shall physically mark the agreed boundaries of all areas in which vegetation is to be removed and protect any areas in which trees or vegetation are to be retained, by robust, readily visible fencing, with signs prohibiting entry of vehicles or personnel.

## **59.2 Vegetation Removal**

59.2.1 The Contractor shall remove vegetation from within the ROW only after he receives written authorization from the Engineer.

59.2.2 The Contractor shall prohibit workers from cutting trees or deliberately damaging any vegetation outside the ROW, including in the vicinity of accommodation camps and shall ensure that all such camps are provided with adequate power and cooking fuel at all times.

59.2.3 The Contractor shall keep appropriate records of the agreed ROW boundaries and other measures and shall regularly monitor to ensure that no vegetation is damaged outside.

## **59.3 Topsoil Removal and Storage**

59.3.1 The Contractor shall prepare a detailed Stockpile Area Management Plan (SAMP) which shall be submitted to the Engineer for review before construction begins. It shall include stockpile locations and prevention of runoff/dust control of fine particles.

59.3.2 Stockpiles shall be located in purpose-built storage areas, preferably within the ROW, which are more than 500 m from any inhabitation or waterway, in areas that are not subject to flooding.

59.3.3 Stockpile slopes shall not exceed 1:2 and height shall not exceed 2 m and surfaces shall be covered with securely-fixed tarpaulins or via an alternative method subject to approval by the Engineer.

59.3.4 The Contractor shall prohibit the entry of vehicles and storage of objects in stockpile areas to prevent soil compaction and shall keep multiple-handling of stored soil to a minimum.

59.3.5 The Contractor shall utilize removed topsoil in this project as much as possible: in top dressing embankments and fill slopes; reinstating borrow pits and other disturbed areas after use and for other purposes.

## **59.4 Sites of Temporary Works**

59.4.1 To prevent unnecessary damage of land, the Contractor shall locate sites for all temporary works and storage areas except the borrow pits, the quarries and the stock pile areas within the approved ROW wherever possible.

59.4.2 If there is no alternative to locating certain temporary worksites outside the ROW, the Contractor shall ensure that all such sites are located at least 500 m from the nearest inhabited area, on land that owners are willing to sell or lease. The Contractor shall be solely responsible for negotiating the sale or rental of such land from the legal owner(s).

59.4.3 The Contractor shall reinstate the land after use to the entire satisfaction of the legal owner(s) and the Engineer.

## **59.5 Flood Prevention**

- 59.5.1 The Contractor shall prepare a detailed Site Drainage and Flood Prevention Plan (SDFPP) to maintain natural drainage and avoid causing flooding of construction sites or surrounding areas and shall submit these to the Engineer for approval before construction start. The SDFPP shall include but not be limited to the measures specified in Clause 59.5.2.
- 59.5.2 The Contractor shall not dispose of any material into rivers, streams, natural culverts or drains.
- 59.5.3 The Contractor shall incorporate suitable drainage structures into all construction sites, sufficient to prevent flooding of the site and adjacent areas during monsoon rainfall and shall provide the Engineer with written proposals and drawings of proposed drainage and flood prevention measures for approval before construction begins.

## **60 ACCOMMODATION CAMP MANAGEMENT**

- 60.1.1 The Contractor shall prepare a detailed Accommodation Camp Management Plan(ACMP) which shall be submitted to the Engineer for review before construction begins. It shall include particularly prevention of runoff/dust control of fine particles.
- 60.1.2 In the pre-construction period the Contractor shall identify potential locations for worker accommodation camps at which the social and environmental impacts of building and operating the camps are expected to be minimal. All such locations shall be at least 500 m from the nearest inhabited area, within the project ROW, or if outside the ROW shall be on land that the owners are willing to lease or sell.
- 60.1.3 Final camp locations shall be selected on the basis of the Engineer's review, after which it shall be the Contractor's sole responsibility to obtain all necessary approvals/authorisations from national, state and local authorities for the establishment and operation of all camps. Copies of all necessary approvals shall be provided to the Engineer in advance of any work on the proposed sites.
- 60.1.4 If chosen camp site(s) are outside the ROW, it is the Contractor's sole responsibility to arrange to rent or purchase the land from the legal owner(s).
- 60.1.5 Camp design, construction and operation shall comply in full with any and all conditions imposed by national, state or local authorities and by the Engineer and with all appropriate legislation. The Contractor shall regularly provide the Engineer (and competent authorities if required by the consent conditions) with appropriate evidence to demonstrate that compliance is being maintained.
- 60.1.6 The Contractor shall consult the appropriate competent authorities regarding the treatment and disposal of wastewater from each camp, shall obtain the necessary authorisation and design and construct the treatment and disposal system accordingly.
- 60.1.7 Wastewater disposal shall comply at all times with effluent discharge standards and any other conditions that may be imposed by the competent authority and the Contractor shall regularly provide the Engineer (and competent authority if required by consent conditions) with data demonstrating that consent conditions are being met.
- 60.1.8 At all camps the Contractor shall provide separate garbage bins for biodegradable and non-biodegradable material and litter bins in the accommodation blocks and shall ensure that each site is tidied daily and that garbage is taken away/disposed of at least thrice a week.

## **61 BORROW PITS AND QUARRY SITES**

- 61.1.1 The Contractor shall prepare a detailed Borrow Pit and Quarry Site Management Plan(BPQSM) which shall be submitted to the Engineer for review before construction begins. It shall include proposed location and transportation routes and environmental and social impacts and its management and mitigation measures.
- 61.1.2 To avoid impacts on the landscape and topography from indiscriminate excavation, the Contractor shall re-use material from cutting and other necessary excavation work in the project as much as possible and shall source all other required soil, stone, aggregate and other construction materials from properly licensed quarries as far as possible.
- 61.1.3 In the case of borrow pits, the Contractor shall identify suitable site(s) and submit details, including a location map and proposed transportation routes, to the Engineer for consent. The location and exploitation of borrow pits shall comply with IRC 10: 1961 and no borrow pits or access roads shall be located less than 200 m from any inhabitation.
- 61.1.4 Consent from the Engineer is dependent on appropriate selection of locations to minimize environmental and social impacts (to be confirmed by site inspection), so the Contractor should include with his application an assessment of the potential impacts of the borrow operation and a description of any proposed mitigation.
- 61.1.5 On receipt of the consent from the Engineer, the Contractor shall be solely responsible for negotiating the sale or rental of all required land from the legal owner(s).
- 61.1.6 The Contractor is also solely responsible for obtaining all consents and approvals from government competent authorities as required by law and shall provide the Engineer with copies of all necessary approvals and landowner agreements (including confirmation of receipt of payments made as per the agreement with the legal land owner(s)), before commencing any work associated with the borrow operation .
- 61.1.7 Borrow pit operations shall only commence on receipt of written authorization from the Engineer.
- 61.1.8 After completion of the borrow operations, the Contractor shall reinstate the land to the entire satisfaction of the legal owner(s) and the Engineer.

## **62 CONSTRUCTION WATER AND RAIN WATER HARVESTING**

- 62.1.1 The Contractor shall prepare a detailed Construction Water and Rain Water Harvesting Plan which shall be submitted to the Engineer for review before construction begins.
- 62.1.2 The Contractor shall bear sole responsibility for organizing the supply and storage of water needed for the construction process and shall make all necessary arrangements with the relevant government authorities and comply in full with any charges or other conditions specified by them.
- 62.1.3 In advance of any water use the Contractor shall inform the Engineer of proposed water sources and arrangements made and shall provide the Engineer with copies of all official approvals.
- 62.1.4 The Contractor shall ensure that usage volumes or rates of extraction agreed by the competent authorities are not exceeded.

- 62.1.5 The Contractor shall prepare and submit to the Engineer plans to minimise the wastage of water and prevent runoff into surface and underground water sources and shall implement the water conservation and pollution prevention plans on approval by the Engineer. In certain cases, it may be advantageous to convert borrow pit area into community ponds to augment the groundwater condition, with the consent of the land owner(s) and local Panchayat.
- 62.1.6 Necessary permissions shall be obtained from the competent authority before abstraction of surface water or groundwater. Groundwater abstraction for construction purposes shall not be done in the area listed by Central Ground Water Authority as notified for control and regulation of ground water.
- 62.1.7 The Contractor shall not abstract water from existing ponds without the consent of the local people/Panchayat.
- 62.1.8 Where feasible as part of the construction works, the Contractor shall develop plans and implement rainwater harvesting schemes as per Central Ground Water Board (CGWB) guidelines. The Contractor shall be responsible for obtaining approval from the competent authority for any such proposals.

## **63 POLLUTION PREVENTION AND CONTROL**

### **63.1 General**

- 63.1.1 The Contractor shall prepare a detailed Pollution Prevention and Control Plan (PPCP), which shall be submitted to the Engineer for review before construction begins. It shall describe pollution control measures relating to air, water, noise and vibration. *Inter alia* this shall describe how compliance with the above legislation will be achieved, how liquid and solid emissions/wastes will be controlled. It shall also describe how clean-up any pollution occur including operational procedure and monitoring methods.

### **63.2 POLLUTION FROM VEHICLES, MACHINERY AND EQUIPMENT**

- 63.2.1 In addition to the requirements of any consent conditions imposed by the competent authorities, the Contractor shall take the measures listed below to reduce the pollution and noise by vehicles, machinery and other equipment.
- 63.2.2 All vehicles, machinery or other equipment used in the construction process shall be three years or less from the date of manufacture at the commencement date of the Services.
- 63.2.3 All vehicles, machinery or other equipment shall conform to the requirements of The Central Motor and Vehicle Act 1988 and other relevant national and state legislation and the appropriate norms of the Bureau of Indian Standards (BIS) and shall be fitted with the most up-to-date appropriate equipment for the reduction of noise and atmospheric and other emissions.
- 63.2.4 All vehicles, machinery and other equipment shall be maintained, serviced and repaired where necessary, according to manufacturers' specifications and recommended schedules; the Contractor shall keep a schedule and records of all such activities and provide these to the Engineer for inspection on request.
- 63.2.5 The Contractor shall conduct and document regular inspections by appropriately qualified experts to identify and remediate any mechanical defects and wear and tear before the performance of the vehicles, machinery or other equipment affects their fitness for purpose or environmental performance.

- 63.2.6 The Contractor shall also conduct and document regular inspections of all vehicles, machinery or other equipment to be used in bridge or culvert construction or any other work near waterways, to confirm that: all plant is clean, fit for purpose and there is no leakage of oil or grease and that plant left on site is safely and appropriately stored in facilities with suitable spill prevention provision.

## **64 WATER QUALITY**

### **64.1 General**

- 64.1.1 The Contractor shall comply in full with all relevant requirements of national legislation governing water quality, including but not necessarily limited to The Environment (Protection) Act 1986 and Environment (Protection) Amendment Rules 2002 (amended 2003, 2004, 2005, 2006, 2007 and 2008) and the Water (Prevention and Control of Pollution) Act 1974 (amended 1988).

- 64.1.2 The Contractor shall comply at all times with any specific requirements of these and any other relevant statutes, including prescribed water quality limits and standards as per the following IS codes/CPCB norms/EP rules and any other relevant legislation, code or guidelines:

- Drinking Water Quality Standards (as per IS: 10500)
- Water Quality Criteria and Standards for Freshwater Classification (CPCB, 1979)
- Tolerance Limits for Inland Surface Waters (as per IS:2296)
- General Standards for Discharge of Effluents [as per Environment (Protection) Rules, 1986]

- 64.1.3 The Contractor is solely responsible for obtaining all consents and approvals from government competent authorities as required by national laws on water quality and shall provide the Engineer with copies of all necessary approvals before construction begins.

- 64.1.4 The Contractor shall comply in full with any conditions imposed by the competent authorities when granting consent and shall regularly provide the Engineer (and competent authorities if required by the consent conditions) with appropriate evidence to demonstrate that compliance is being maintained.

- 64.1.5 Notwithstanding the above, the Contractor is expected to maintain the highest standards of environmental performance throughout all his work and to take all necessary precautions to avoid causing any significant pollution of any natural water, both surface and underground. Precautions shall include but not be limited to those specified in Clause 64.2 to 64.5.

### **64.2 Siltation Control**

- 64.2.1 The Contractor shall not obtain any construction materials from the beds of rivers, streams, lakes or other water bodies, except with prior approval of the competent authority. He shall bear related all costs and abide by the stipulated conditions, if any.

- 64.2.2 The Contractor shall install silt runoff prevention measures as consented by the Engineer at the base of embankments constructed near surface water bodies and shall maintain such measures in place until embankment slopes are fully stabilised by grassing or other means as approved.

- 64.2.3 Stockpiled soil, sand and any other fine-grained construction materials shall be covered with secure tarpaulins or via an alternative method subject to the approval by the Engineer and stored in fully waterproof enclosures, located more than 100 m from any surface water.
- 64.2.4 Where construction work is conducted in a natural waterway the Contractor shall prepare and submit to the Engineer for approval before such work begins, detailed plans to minimise and contain sediment disturbance.
- 64.2.5 During the construction period, the Contractor shall arrange for removal/cleaning of deposited silt from drainage channels and outlet points within the project influence area before the monsoon season. Rejuvenation of the drainage system by removing encroachments/congestions shall also be ensured.

### **64.3 Erosion Control**

- 64.3.1 To minimise slope erosion and runoff of silt-laden rainfall, the Contractor shall conduct all cut and fill operations outside the monsoon season and shall protect all cut slopes as per the design requirements as soon as the final profile has been reached.
- 64.3.2 While slopes are being cut or constructed, if areas are to be left uncovered for more than 5 days before further profiling, soil surfaces shall be suitably protected temporarily as consented by the Engineer, to reduce erosion.
- 64.3.3 The Contractor shall provide adequate temporary or permanent drainage alongside all slope areas before excavation/cutting begins and shall provide adequate settlement lagoons/chambers to collect runoff and allow sediment to settle out before water is discharged to a natural waterway.
- 64.3.4 Soil erosion shall be visually checked by the Contractor periodically on slopes and high embankment areas. In case soil erosion is found, suitable measures shall be taken to control soil erosion.
- 64.3.5 The Contractor shall be responsible to ensure that all the slopes are fully stabilised and protected as per the design requirements before being taken over by the Employer

### **64.4 Wastewater Disposal**

- 64.4.1 Notwithstanding the requirements of any consent conditions applied by the statutory authority, all site drainage and waste water shall be adequately treated including installation of a Sewage Treatment Plant, if required, before disposal to the natural environment and no liquid or other material shall be allowed to drain away untreated.
- 64.4.2 Site drainage shall be retained in lagoons or chambers for a sufficient time to allow settlement of a significant proportion of the suspended sediment before water is decanted to a natural water body.
- 64.4.3 Wastewater from toilets, washrooms and other sanitary facilities shall be treated to national legal standards and discharged as prescribed by consent conditions applied by the statutory authority.
- 64.4.4 Any oil and grease contents of waste water shall be trapped and recovered before discharge to drain or water body.
- 64.4.5 Sufficient toilet and washroom facilities shall be provided at all construction sites for the numbers of workers and staff on site at all times and all such facilities shall be fully cleaned and re-equipped at least daily.

## **64.5 Accidental Spillage**

- 64.5.1 The Contractor shall comply in full with the requirements of all relevant legislation pertaining to the storage, handling and disposal of hazardous chemicals used in the construction process, including, but not necessarily limited to the Manufacture, Storage and Import of Hazardous Chemicals (Amendment) Rules 2000 and the "Hazardous Waste (Management, Handling and Trans-boundary Movement) Rules 2008" and its amendment.
- 64.5.2 The Contractor is solely responsible for obtaining any consents and approvals that may be necessary under these and any other relevant statutes, for complying with any consent conditions set by the competent authority and for providing the Engineer (and competent authority if necessary) with regular monitoring data demonstrating that those conditions are being met.
- 64.5.3 The Contractor shall adopt all necessary measures during the monsoon season to avoid soil erosion and sedimentation, accidental spillage, accident risks to workers and damage to already constructed works, near the water bodies considering their nature, extent and site-specific conditions.
- 64.5.4 The Contractor shall locate all parking areas, vehicle/machinery or equipment maintenance yards and storage areas for fuel, oil or any other potentially toxic materials within the ROW of construction areas and more than 100 m from any water body.
- 64.5.5 All parking areas and vehicle/plant maintenance yards shall be floored with waterproof hard-standing and drainage from all such areas shall be collected and treated as required to meet legal discharge standards and any other consent conditions.
- 64.5.6 Fuel, oil and any other hazardous liquids shall be stored only in concrete-floored and bunded areas and the volume of the bunded areas must be sufficient to retain all the stored liquid in the event of leakage.
- 64.5.7 Refuelling shall only be conducted in areas that are dedicated for this purpose and provided with floors of waterproof concrete, from which all drainage is collected and passed through an oil/water separator before discharge.
- 64.5.8 Accurate records shall be kept documenting all fuelling and maintenance, plus any spill events and action taken.
- 64.5.9 Appropriate spill containment and clean-up equipment shall be provided at all fuel storage, refueling and vehicle maintenance areas and operators shall be appropriately trained in their normal activities as well as pollution control and remediation.
- 64.5.10 Waste oil from vehicle maintenance shall be collected in sealed containers and stored safely in sealed damage-proof containers prior to collection and disposal.
- 64.5.11 All waste oil shall be disposed of as per the Central Pollution Control Board (CPCB) and/or State Pollution Control Board (SPCB) guidelines as applicable.

## **65 AIR QUALITY**

### **65.1 General**

- 65.1.1 The Contractor shall comply in full with all relevant requirements of national legislation governing air quality, including but not necessarily limited to The Environment (Protection) Act 1986 and Environment (Protection) Amendment Rules 2002 (amended 2003, 2004, 2005, 2006, 2007 and 2008) and the Air (Prevention and Control of

Pollution) Act 1981 (amended 1987).

- 65.1.2 The Contractor shall comply at all times with any specific requirements of these and any other relevant statutes, including prescribed air quality limits and standards as follows:
- National Ambient Air Quality Standards (NAAQS) amended till date and
  - General emission standards as per the Environment (Protection) Rules, 1986.
- 65.1.3 The Contractor is solely responsible for obtaining all consents and approvals from government competent authorities as required by national laws on air quality and shall provide the Engineer with copies of all necessary approvals before construction begins.
- 65.1.4 The Contractor shall comply in full with any conditions imposed by the competent authorities when granting consent and shall regularly provide the Engineer (and competent authorities if required by the consent conditions) with appropriate evidence to demonstrate that compliance is being maintained.
- 65.1.5 Notwithstanding the above, the Contractor is expected to maintain the highest standards of environmental performance throughout all his work and to take all necessary precautions to avoid causing any significant air pollution. Precautions shall include but not be limited to those specified in Clause 65.2.

## **65.2 Dust Control**

- 65.2.1 The Contractor shall water all unpaved roads in all construction sites at least thrice daily in dry weather to reduce dust and shall apply the same watering regime to areas of exposed soil during dry and windy weather.
- 65.2.2 All fine-grained loose material (soil, sand, etc) shall be covered with secure tarpaulins when stored on site and when carried on- or off-site on trucks.
- 65.2.3 Vehicle speeds on all construction sites shall be limited to a maximum of 20 kmph at all times.
- 65.2.4 Wheel washing facilities shall be provided and used by all vehicles at all site exits prior to travelling on public roads.
- 65.2.5 Crushers and any other machinery likely to produce significant dust shall be located at least 1 km from the nearest inhabitation, downwind of the predominant wind direction. Permission/NOC shall be obtained from the State Pollution Control Board for installing and operating all crusher units. The Contractor shall provide the Engineer with copies of relevant certification to show that all such machinery is fitted with appropriate dust reduction/extraction equipment.

## **66 NOISE**

### **66.1 General**

- 66.1.1 The Contractor shall comply in full with all relevant requirements of national legislation governing noise, including but not necessarily limited to The Environment (Protection) Act 1986 and Environment (Protection) Amendment Rules 2002 (amended 2003, 2004, 2005, 2006, 2007 and 2008) and the Noise Pollution (Regulation and Control) Rules 2000.
- 66.1.2 The Contractor shall comply at all times with any specific requirements of these and



any other relevant statutes, including prescribed noise limits and standards as per Ambient Noise Level Limits (in Leq dB(A)) specified in Environment Protection Rules, 1986, Schedule III.

- 66.1.3 The Contractor is solely responsible for obtaining all consents and approvals from government competent authorities as required by national laws on noise pollution and shall provide the Engineer with copies of all necessary approvals before construction begins.
- 66.1.4 The Contractor shall comply in full with any conditions imposed by the competent authorities when granting consent and shall regularly provide the Engineer (and competent authorities if required by the consent conditions) with appropriate evidence to demonstrate that compliance is being maintained.
- 66.1.5 Notwithstanding the above, the Contractor is expected to maintain the highest standards of environmental performance throughout all his work and to take all necessary precautions to avoid causing any significant noise pollution or nuisance. Precautions shall include but not be limited to those specified in Clause 66.2.1 and 66.2.4.

## **66.2 Control Requirements**

- 66.2.1 The Contractor shall ensure that noise generated by work carried out by the Contractor and his sub-contractors during daytime and night time shall not exceed the stipulated maximum permissible noise limits, whether continuously or intermittently. In the event of a breach of this requirement, the Contractor shall immediately re-deploy or adjust the relevant equipment or take other appropriate measures to reduce the noise levels and thereafter maintain them at levels which do not exceed the said limits. Such measures may include without limitation the temporary or permanent cessation of use of certain items of equipment.
- 66.2.2 The Contractor shall submit to the Engineer a Noise Monitoring and Control Plan (NMCP) to supplement PPCP. It shall include full and comprehensive details of all powered mechanical equipment, which he proposes to use during daytime and night time and of his proposed working methods and noise level reduction measures. The NMCP shall include detailed noise calculations levels to demonstrate the anticipated noise generation by the Contractor. The NMCP shall be reviewed on a regular basis and updated as necessary to assure that current construction activities are addressed.
- 66.2.3 The Contractor shall cease any activity likely to produce significant noise (such as concrete mixing, excavation, operation of heavy vehicles, etc.) at all locations that are less than 150 m from inhabited areas, between the hours of 10.00 pm and 6.00 am and on Sundays and public holidays. Work sites near sensitive locations like schools and hospitals shall be surrounded by the temporary noise barriers.
- 66.2.4 Construction materials should be operated and transported in such a manner as not to create unnecessary noise as outlined below:
  - i) Perform Work within the procedures outlined herein and comply with applicable codes, regulations and standards established by the Central and State Governments and their agencies.
  - ii) Keep noise to the lowest reasonably practicable level. Appropriate measures will be taken to ensure that construction works will not cause any unnecessary or excessive noise, which may disturb the occupants of any nearby dwellings, schools, hospitals, or premises with similar sensitivity to noise. Use equipment with effective noise-suppression

devices and employ other noise control measures as to protect the public.

- iii) Schedule and conduct operations in a manner that will minimize, to the greatest extent feasible, the disturbance to the public in areas adjacent to the construction activities and to occupants of buildings in the vicinity of the construction activities.
- iv) As far as possible, stationary noise making equipment shall be located along un-inhabited areas.

**67 VIBRATION**

67.1.1 In locations where the alignment is close to sensitive structures, historical / heritage structures, the Contactor shall control vibration at such locations. The control measures of vibration level at such sites shall be submitted to the Engineer for his approval. The scheme shall include:

- i) Monitoring requirements for vibrations at regular intervals throughout the construction period.
- ii) Pre-construction structural integrity inspections of sensitive structures in project activity.
- iii) Information dissemination about the construction methods, probable effects, quality control measures and precautions to be used.
- iv) The vibration level limits at work sites adjacent to the alignment shall conform to the permitted values of Peak Particle Velocity (PPV) as given in the table below.

Sl. No.	Condition of Structure	Max. PPV in mm/sec
1.	Most structures in “good condition”	25
2.	Most structures in “fair condition”	12
3.	Most structures in “poor condition”	5
4.	Water supply structures	5
5.	Heritage structures/bridge structures	5

**68 SOLID WASTE MANAGEMENT**

68.1.1 The Contractor shall comply in full with the requirements of all relevant legislation pertaining to the management and disposal of solid waste, including, but not necessarily limited to the Environment (Protection) Act 1986 and Environment (Protection) Amendment Rules 2002 (amended 2003, 2004, 2005, 2006, 2007 and 2008) and the Municipal Solid Wastes (Management and Handling) Rules 2000 and local legislation governing construction and demolition wastes.

68.1.2 The Contractor is solely responsible for obtaining any consents and approvals that may be necessary under these and any other relevant statutes, for complying with any

consent conditions set by the competent authority and for providing the Engineer (and competent authority if necessary) with regular data demonstrating that those conditions are being met.

- 68.1.3 The Contractor shall prepare a detailed Solid Waste Management Plan (SWMP), which shall be submitted to the Engineer for review before construction begins.
- 68.1.4 When preparing the SWMP the Contractor shall contact the relevant authorities at state and local level and make arrangements to deposit waste materials from construction sites at existing sanitary landfills wherever possible, or if such facilities are not available within a reasonable distance from any locations, at alternative licensed waste disposal sites.
- 68.1.5 The SWMP shall describe how compliance with the above legislation will be achieved and how all solid waste will be collected and stored at Work Areas, removed and transported for disposal and where and how it will be deposited. Special arrangements for hazardous waste shall be described, including the manner in which such waste will be deposited to prevent escape of any material over the long term. Measures to keep sites in a tidy and sanitary condition will also be described, along with measures to minimise waste and re-use and recycle used materials.
- 68.1.6 No potentially polluting material is to be deposited at unlicensed sites and no waste shall be burnt.
- 68.1.7 With the approval of the Engineer, surplus inert material (excavated spoil, building rubble, etc.) that cannot be used as infill or for other purposes on the project may be deposited at unlicensed sites with the consent of the owner, if it can be retained indefinitely without causing pollution or other environmental hazard or damage and if it does not create an unsightly appearance. Public perception and consent from the village Panchayats about the location of debris disposal site has to be obtained before finalizing the location.

## **69 ARCHAEOLOGY**

- 69.1.1 When the working near scheduled ancient monuments or sites, the Contractor shall obtain NOC from the Archaeological Survey of India for any activities within the Prohibited Area (100m from the Protected Limit) and Regulated Area (200m from the Protected Limit) according to ancient monuments and Archaeological Sites and Remains Act 1958.
- 69.1.2 The Contractor shall commission archaeological expert(s) to conduct a detailed assessment of all Work Areas to estimate the risk of encountering previously undiscovered historical remains during excavation and prepare a Physical Cultural Resources Management Plan (PCRMP). The PCRMP shall set out procedures to be adopted to minimise the risk of causing accidental damage during excavation work and other ground disturbance and to ensure that any material discovered is recognised and dealt with appropriately.
- 69.1.3 *Inter alia* the PCRMP shall include a “chance finds” procedure that involves: a qualified field archaeologist, familiar with international best practice, observing excavation work in any especially sensitive areas; stopping work immediately to allow further investigation if any finds are suspected and calling in the State or Central archaeological authority in the event of a significant find and taking any action they require to ensure its removal or protection *in situ*.

## **70 CONTRACTOR'S DEMOBILIZATION**

- 70.1.1 The Contractor shall prepare Site Rehabilitation Plans(SRPs) for all temporarily occupied sites (including but not limited to construction sites, storage yards, accommodation camps, borrow areas, etc) and shall submit these to the Engineer for approval well before each site is vacated. Each plan shall include but not be limited to the measures specified in Clause 16 70.1.2 to 70.1.6.
- 70.1.2 All garbage, debris and hazardous materials shall be removed and deposited as directed by competent authorities, at approved disposal locations.
- 70.1.3 All equipment, plant and other materials shall be removed from all sites, all trenches shall be filled and any waste disposal pits shall be filled and sealed.
- 70.1.4 Infrastructure such as buildings, water supply, etc may be left *in situ* if desired by the landowner, otherwise all structures shall be demolished and the debris removed for disposal and all wells and sewage treatment and disposal systems shall be sealed and left in a sanitary condition.
- 70.1.5 Final landscaping shall be as agreed with the landowner and may include such reasonable measures as slope grading, grass seeding, tree planting, etc.
- 70.1.6 The Contractor shall report completion of site restoration to the Engineer, who shall approve site closure if all actions have been completed according to the Restoration Plan to the satisfaction of the landowner(s).

## **71 AUDIT AND INSPECTION, REPORTING**

### **71.1 Audit and Inspection**

- 71.1.1 The Contractor shall audit the activities described in his ESMP base on ESMoP at weekly, bi-weekly and/or monthly intervals or as otherwise required by the Engineer and shall keep appropriate records of this activity.
- 71.1.2 The Engineer will inspect the Contractor's environmental and social performance in the course of his normal supervision activities and the Contractor will cooperate by providing access to sites, equipment, staff, records, etc. as may be requested by the Engineer either in writing or verbally.
- 71.1.3 At least two week's notice will be given to the Contractor by the Engineer of any formal audit of the Contractor's environmental and social performance and the notice will indicate the areas and activities to be audited and any special requirements, including records to be provided. The Contractor's Senior Environment Officer and other appropriate staff shall accompany the Engineer's staff throughout such an audit as may be requested by the Engineer.

### **71.2 Reporting**

- 71.2.1 The Contractor shall submit a written report to the Engineer at the end of each week and a more detailed report to the Engineer at the end of each month, describing:
- Progress in providing the mitigation measures specified below and described in the ESMP (refer Attachment 2 [Contractor's Environmental and Social Management Plan] to Clause 16 [SHE Requirements] of Specifications);

- The results of each monitoring activity specified in the ESMoP (refer Attachment 3 [Contractor's Environmental and Social Monitoring Plan] to Clause 16 [SHE Requirements] of Specifications), with an explanation of conclusions drawn from the results;
- Any other observations regarding environmental or social matters;
- Any recommendations or requests for authorisation of proposed changes in implementation of the ESMP or ESMoP, with an explanation/justification.

71.2.2 The Contractor shall also meet with the Engineer and his Environmental officers for ad-hoc formal and informal discussions as may be requested by the Engineer and shall report verbally to the Engineer immediately there is any significant non-compliance with consent conditions or prescribed standards, or any significant deviation from the implementation of mitigation as described in the ESMP.

## **PARTVII: PENALTY AND AWARDS**

### **72 CHARGES TO BE RECOVERED FROM CONTRACTOR FOR UNSAFE ACT OR CONDITION**

72.1.1 DFCCIL aims to build an image of one of the best safety conscious organization. Any reportable accident (fatality/injury) results in loss of life and/or property damage but also damages the reputation of the organization. Most of the accidents are avoidable and caused preliminary due to contractors negligence. Hence DFCCIL shall recover the cost of damages from the Contractors for every reportable incident (fatality /injury).

72.1.2 In addition every DFCCIL work site is exposed to public scrutiny as the work is executed just on the ROW. Any unsafe act/unsafe condition observed by public further damages DFCCIL reputation. Because of the non-voluntary compliance of contractors to the condition of contract on SHE and project SHE manual. DFCCIL has introduced an enforcement system design to influence the Contractor's decision making and risk management process in favor of compliance rather than non conformance.

72.1.3 The following table indicates the SHE violations (unsafe act/unsafe condition) that will warrant charges to be recovered from contractors. Penalties shall be applied to the Contractor following repetitive failure to comply with the SHE manual or employer's direct instructions. Where awarded by the employer penalties shall be deducted from the Contractor's running bill.

Sl.No.	Topic	Unsafe Act/Unsafe Condition	Deductible Amount
1.	SHE Policy & Plan	<ul style="list-style-type: none"> <li>• i. SHE Policy                             <ul style="list-style-type: none"> <li>a. non-compliance of Clause 16(2.2)</li> <li>b. Inadequate coverage, not signed</li> </ul> </li> </ul> <p>Not displayed at prominent locations</p>	Rs.5,000 per single violation, compounded to a maximum of Rs.25000 at any single instance.
		<ul style="list-style-type: none"> <li>• ii. SHE Plan                             <ul style="list-style-type: none"> <li>a. Not as per Employers' content and coverage</li> <li>b. Delay in submission</li> <li>c. Not updated as per employer's instruction as per Clause 16(2.2)</li> <li>d. Copies not provided to all required supervisors/ engineers</li> </ul> </li> </ul>	Rs.100,000 per single violation, compounded to a maximum of Rs.200,000 at any single instance.
2.	SHE Organization	<ul style="list-style-type: none"> <li>• i. Not complying to the minimum manpower requirements as mentioned in General Instruction DFCCIL/SHE/001/MPR/28110 5</li> <li>ii. Not filling up the vacancies created due to SHE personnel leaving the Contractor within 14 days.</li> <li>iii. SHE organization not provided with required Audio-visual and other equipment as per General Instruction DMRS/SHE/012/AVE/281105</li> <li>iv. Employing through outsourcing agencies and SHE personal are not in the payroll of the main contractor</li> <li>v. Disobedience/improper conduct of any SHE personnel.</li> <li>vi. Chief SHE Manager not reporting directly to CPM of contractor.</li> </ul>	<p>i.Rs.100,000 per month for first month and Rs.200,000 for subsequent months.</p> <p>ii.Rs.50,000 per month for first month and Rs.100,000 for subsequent months.</p> <p>For items iii, iv, v and vi Rs.50,000 for first violation and Rs.100,000 for subsequent violations.</p>

Sl.No.	Topic	Unsafe Act/Unsafe Condition	Deductible Amount
3.	SHE committees	<ul style="list-style-type: none"> <li>i. Failed to formulate or conduct SHE committee meeting for any month</li> <li>ii. Contractor and Sub-contractor representatives not attending SHE Committee meetings.</li> <li>iii. Failed to conduct Site inspection before conducting SHE committee meeting</li> <li>iv. Failed to send SHE Committee Meeting minutes or Agenda to Employer in time.</li> <li>v. Non-adherence of Clause 16(8.4.1)</li> <li>vi. Non-adherence of Clause 16 (8.6)</li> </ul>	<p>i.Rs.100,000 for the first violation and Rs.500,000 for the subsequent violations.</p> <p>ii.Rs.5,000 to the Contractor of the member who had not attended the meeting for first violation and Rs.25,000 for subsequent violations.</p> <p>For item iii, iv, v and vi Rs.25,000 for first violation and Rs.50,000 for subsequent violations.</p>
4.	ID card	<ul style="list-style-type: none"> <li>i. non-adherence of Clause 16 (9.1, 9.2 and 9.3)</li> </ul>	Rs.100,000 for first violation and Rs.200,000 for subsequent violations.
5.	SHE Training	<ul style="list-style-type: none"> <li>i. non complying to the requirements as mentioned in conditions of contract on SHE and project SHE manual with regard to:                             <ul style="list-style-type: none"> <li>a. Induction training not given</li> <li>b. Supervisor/engineer/manager training not conducted as per Clause 16(10.1.6)</li> <li>c. Refresher training as per clause 10.1.7 and 10.1.11 not conducted</li> <li>d. Tool-box talk not conducted as per Clause 16(10.1.8)</li> <li>e. Skill development training not conducted as Clause 16(10.1.9)</li> <li>f. Daily Safety Oath not conducted as per Clause 16(10.1.10)</li> <li>g. Top management behavior based SHE training conducted</li> </ul> </li> </ul>	For item a to g Rs.50,000 for first violation on and Rs.100,000 for subsequent violations.
6.	SHE inspection	<ul style="list-style-type: none"> <li>i. Not complying to the requirements as mentioned in conditions of contract on SHE and project SHE manual as per Clause 16(11).</li> <li>ii. Non compliance of Clause 16(11.5.3)</li> </ul>	Rs.50,000 for first violation and Rs.100,000 for subsequent violations.
7.	SHE audit	<p>Internal Audit: MARS</p> <ul style="list-style-type: none"> <li>i. Not conducted as per SHE Plan</li> <li>ii. Report not sent to Employer</li> <li>iii. Action not taken for any month</li> </ul> <p>External Audit</p> <ul style="list-style-type: none"> <li>iv. Not conducted as per SHE Plan</li> <li>v. Report not sent to Employer</li> <li>vi. Action not taken for any month</li> </ul>	<p>For item i. to iii. Rs.50,000 for first violation and Rs.100,000 for subsequent violations.</p> <p>For item iv to vi Rs.100,000 for first violation and Rs.200,000 for subsequent violations.</p>

Sl.No.	Topic	Unsafe Act/Unsafe Condition	Deductible Amount
8.	SHE Communication	<ul style="list-style-type: none"> <li>• i. Important days to be observed for SHE awareness as furnished by employer not observed</li> <li>ii. Posters as furnished by Employer not printed and displayed</li> </ul>	i.Rs. 10,000 for first violation and Rs.50,000 for subsequent violations. ii.200,000 per contract.
9.	SHE Submittals	<ul style="list-style-type: none"> <li>• i. Non compliance of Clause 16(14.1).</li> <li>ii. Non compliance of Clause 16(14.2).</li> <li>iii. Non compliance of Clause 16(14.3).</li> </ul>	For item i. Rs.50,000 for first violation and Rs.100,000 for subsequent violations. For item ii and iii Rs.100,000 for first violation and Rs.200,000 for subsequent violations.
10.	Injury and Incidence reporting	<ul style="list-style-type: none"> <li>• i. Fatal accidents</li> <li>ii. Injury accident</li> <li>iii. Abnormal delay in reporting accidents of willful suppression of information about any accidents/dangerous occurrence as per Clause 16(15.1.4)</li> <li>iv. Delay in informing about any accidents/dangerous incidents.</li> <li>v. Non-compliance of Clause 16(15.4)</li> </ul>	iRs.500,000 for first fatality and Rs.100,000 for every subsequent fatality. ii.Rs.100,000 for first grievously injured person and Rs.200,000 for every subsequent grievously injured person (grievous injury as defined by Workmen Compensation Act). iii.Rs.100,000 for first violation and Rs.200,000 for subsequent violations for items iv and v Rs.50,000 for first violation and Rs.100,000 for subsequent violations.
11.	Emergency preparedness plan	Non-compliance of Clause 16(16.1.1 to 16.1.6)	Rs.100,000 for non-compliance of any of the clauses.
12.	Housekeeping	<ul style="list-style-type: none"> <li>• i. Housekeeping maintenance register not properly maintained up to date</li> <li>ii. Surrounding areas of drinking water tanks/taps not hygienically cleaned/maintained</li> <li>iii. Office, stores, toilet/urinals not properly cleaned and maintained.</li> <li>iv. Required dustbins at appropriate places not provided / not cleaned.</li> <li>v. Stairways, gangways, passageways blocked.</li> <li>vi. Lumber with protruding nails left as such</li> <li>vii. Openings unprotected</li> </ul>	Rs.10,000 per single violation. Compounded to a maximum of Rs.100,000 at any single instance.



Sl.No.	Topic	Unsafe Act/Unsafe Condition	Deductible Amount
		<ul style="list-style-type: none"> <li>viii. Excavated earth not removed within a reasonable time.</li> <li>ix. Truck carrying excavated earth not covered/tyres not cleaned.</li> <li>x. Vehicles/equipment parked/ placed on roads obstructing free flow of traffic.</li> <li>xi. Unused surplus cables/steel drums lying scattered</li> <li>xii. Scraps lying scattered</li> <li>xiii. Wooden scraps, empty wooden cable</li> </ul> Water stagnation leading to mosquito breeding	
13.	Working at height/ Ladders and Scaffolds	<ul style="list-style-type: none"> <li>• i. Not using or anchoring Safety Belt</li> <li>ii. Not using Safety Net</li> <li>iii. Absence of life line or anchorage point to anchor safety belt</li> <li>iv. Non-compliance of Clause 16(27.10)</li> <li>v. Using Bamboo ladders.</li> <li>vi. Painting of ladders</li> <li>vii. Improper usage (less than 1m extension above landing point, not maintaining 1:4 ratio)</li> <li>viii. Aluminum ladders without base rubber bush.</li> <li>ix. Usage of broken/weak ladders.</li> <li>x. Usage of re-bar welded ladders.</li> <li>xi. Improper guardrail, toe board, barriers and other means of collective protection</li> <li>xii. Improper working platform</li> <li>xiii. Working at unprotected fragile surface</li> <li>xiv. Working at unprotected edges.</li> </ul>	Rs.10,000 per single violation.  Compounded to a maximum of Rs.100,000 at any single instance.
14.	Lifting appliances and gear	<ul style="list-style-type: none"> <li>• i. Non availability of fitness certificate as per clause 30.1.3</li> <li>ii. Documents not displayed on the machine or not available with the operator as per Clause 16(30.1.4)</li> <li>iii. Maximum Safe Working Load not written on the machine as per Clause 16(30.1.5)</li> <li>iv. Non compliance of Clause 16(30.16)</li> <li>v. Non compliance of Clause 16(30.2)</li> <li>vi. Automatic safe load indicator not provided or not in working condition as per Clause 16(30.3)</li> <li>vii. Age of the operator less than 21 years or without any licence and non-compliance of other item as per Clause 16(30.4)</li> <li>viii. Non-compliance of Clause 16(30.5)</li> <li>ix. Non-compliance of any of the items mentioned regarding rigging requirements as per Clause 16(30.6)</li> <li>x. Failure to submit method statement in case of all critical lifting.</li> <li>xi. Person riding on crane.</li> <li>xii. Creating more noise and smoke</li> <li>xiii. Absence of portable fire extinguisher in driver cabin</li> </ul>	Rs.50,000 per single violation.  Compounded to a maximum of Rs.500,000 at any single instance.

Sl.No.	Topic	Unsafe Act/Unsafe Condition	Deductible Amount
		xiv. Fail to guard hoist platform xv. No fencing of hoist rope movement area xvi. Hoist platform not in the horizontal position	
15.	Launching operation	Non-adherence of any of the provisions mentioned in Clause 16(31.1.2)	Rs.50,000 for first violation and Rs.100,000 for subsequent violations.
16.	Site Electrical safety	<ul style="list-style-type: none"> <li>• i. Non-compliance of Clause 16(36.1)</li> <li>ii. Non-compliance of Clause 16(36.2.4, 36.2.5)</li> <li>iii. Non-compliance of Clause 16(36.3.1)</li> <li>iv. Non-compliance of Clause 16(36.7, 36.8 and 36.9.1)</li> <li>v. Non-compliance of Clause 16(36.10 and 36.13)</li> <li>vii. Exposed electric lines (fermentative damage) and circuits in the workplace</li> <li>viii. Inserting of bare wires into the socket</li> <li>ix. Improper grounding for the electrical appliances</li> <li>x. Electrical cables running on the ground</li> <li>xi. Non-compliance Clause 16(37)</li> </ul>	Rs.10,000 per single violation.  Compounded to a maximum of Rs.100,000 at any single instance.
17.	Hand tools and Power tools	Non-compliance of Clause 16(38)	Rs.10,000 per single violation.  Compounded to a maximum of Rs.100,000 at any single instance.
18.	Gas cutting	<ul style="list-style-type: none"> <li>• i. Wrong colour coding of cylinder.</li> <li>ii. Cylinders not stored in upright position.</li> <li>iii. Flash back arrester, non-return valve and regulator not present or not in working conditions.</li> <li>iv. Fail to put cylinders in a cylinder trolley.</li> <li>v. Damaged hose.</li> <li>vi. Using domestic LPG cylinders.</li> <li>vii. Fail to store cylinder 6.6m away from fire prone materials.</li> <li>viii. Fail to use hose clamps</li> <li>ix. Fire extinguisher not placed in the vicinity during operation.</li> </ul>	Rs.10,000 per single violation.  Compounded to a maximum of Rs.100,000 at any single instance.
19.	Welding	<ul style="list-style-type: none"> <li>• i. Voltmeter and ammeter not working</li> <li>ii. Improper grounding and return path.</li> <li>iii. Damaged welding cable</li> <li>iv. Bare openings in the cable.</li> <li>v. Non-availability of separate switch in the transformer</li> </ul>	Rs.10,000 per single violation.  Compounded to a maximum of Rs.50,000 at any single instance.

Sl.No.	Topic	Unsafe Act/Unsafe Condition	Deductible Amount
		<ul style="list-style-type: none"> <li>vi. Non-availability of main switch control to switch off power to the welding unit.</li> <li>vii. Usage of reinforcement rod as return conductor</li> <li>viii. Damaged holder</li> <li>ix. Fire extinguisher not placed in the vicinity during operation.</li> </ul>	
20.	Fire precaution	<ul style="list-style-type: none"> <li>• i. Smoking and open flames in fire prone area</li> <li>ii. Using more than 24V portable electrical appliances in the fire prone area</li> <li>iii. Not proper ventilation in cylinder storage area.</li> <li>iv. Absence of fire extinguishers</li> <li>v. Fire extinguishers not refilled once in a year.</li> <li>vi. Fire extinguisher placed in a not easily accessible location.</li> </ul>	<p>Rs.5,000 per single violation.</p> <p>Compounded to a maximum of Rs.25,000 at any single instance.</p>
21	Excavation and confined space	<ul style="list-style-type: none"> <li>• i. Non-compliance of Clause 16(44.1)</li> <li>ii. Non-compliance of Clause 16(44.2)</li> </ul>	<p>For any item from i and ii Rs.10,000 per single violation.</p> <p>Compounded to a maximum of Rs.50,000 at any single instance. Rs.10000 per first violation and Rs.50,000 for subsequent violations.</p>
22.	Work permit system	<ul style="list-style-type: none"> <li>• i. Non-compliance of Clause 16(45.1)</li> </ul>	<p>For item i and ii Rs.50,000 per first violation and Rs.100,000 for subsequent violations.</p>
23.	Traffic	<ul style="list-style-type: none"> <li>• i. Non-compliance of Clause 16(46.2.1)</li> <li>ii. Non-compliance of Clause 16(46.4.3)</li> <li>iii. Non-compliance of Clause 16(46.5.2)</li> <li>iv. Non-compliance of Clause 16(46.5.5)</li> <li>v Non-compliance of Clause 16(46.5.11)</li> <li>vi Non-compliance of Clause 16(46.5.12)</li> </ul>	<p>Rs.100,000 per first violation and Rs.200,000 for subsequent violations.</p>
		<p>a. Barricades</p> <ul style="list-style-type: none"> <li>• i. Not Cleaned</li> <li>ii. Not in alignment</li> <li>iii. Not numbered</li> <li>iv. Not painted</li> <li>v. Red lights/reflectors not working</li> <li>vi. Damages not repaired</li> <li>vii. Not secured properly</li> <li>viii. Barricade inspector not employed</li> <li>ix. Protruding parts/portions not repaired</li> <li>x. Barricades maintaining register not properly maintained up to date</li> </ul>	<p>Rs.25,000 per single violation.</p> <p>Compounded to a maximum of Rs.100,000 at any single instance.</p>
		<p>b. Contractor Vehicles</p> <ul style="list-style-type: none"> <li>• i. Over loading of vehicles</li> </ul>	<p>Rs.25,000 per single violation.</p>

Sl.No.	Topic	Unsafe Act/Unsafe Condition	Deductible Amount
		<ul style="list-style-type: none"> <li>ii. Unfit drivers or operators</li> <li>iii. Unlicensed vehicles</li> <li>iv. Absence of traffic marshals</li> <li>v. Absence of reversing alarm</li> <li>vi. Absence of fog light (at winter)</li> <li>vii. Power/hand brakes not in working condition.</li> </ul>	Compounded to a maximum of Rs.100,000 at any single instance.
		<ul style="list-style-type: none"> <li>c. Splashing of Bentonite on roads/non-cleaning of tyres of dumpers and transit mixers                             <ul style="list-style-type: none"> <li>• i. Mishandling of bentonite like splashing of bentonite outside specified width of barricading</li> </ul> </li> <li>ii. Non-cleaning of tyres of dumpers and transit mixers before leaving the site and thereby creating a traffic safety hazard to road users.</li> </ul>	For item i. and ii. a. Rs.100,000 on first observation. b. Rs.200,000 on second observation. c. Rs.300,000 on third and subsequent observations.
24.	Batching plant/Casting yard	Non-adherence of any of the provision mentioned in Clause 16(48)	Rs.10,000 for single violation.  Compounded to a maximum of Rs.100,000 at any single instant.
25.	PPE	<ul style="list-style-type: none"> <li>• i. Not having</li> <li>ii. Not wearing (or) using and kept it elsewhere</li> <li>iii. Using damaged one</li> <li>iv. Using wrong type</li> <li>v. Using wrong colour helmet or helmet</li> <li>vi. Using for other operation (e.g. Using safety helmet for storing materials or carrying water from one place to other)</li> <li>vii. Not conforming to BIS standard</li> <li>viii. Non-compliance of Clause 16(50.16, 50.17 and 50.18)</li> </ul>	From item i. to vi. Rs.200 per single violation.  For item vii. Rs.10,000 for first violation and Rs.50,000 for subsequent violations.  For item viii. Rs.50,000 for first violation and Rs.100,000 for subsequent violations.
26.	Occupational Health	<ul style="list-style-type: none"> <li>• i. Fail to conduct Medical examination to workers.</li> <li>ii. Absence of ambulance van &amp; room</li> <li>iii. Workers not having ID card</li> <li>iv. Inadequate number of toilets</li> <li>v. toilets not cleaned properly</li> <li>vi. Absence of water facilities for toilets and washing places</li> <li>vii. Toilet placed more than 500m from the work site.</li> <li>viii. Absence of drinking water</li> <li>ix. Absence of first-aid person in work site.</li> <li>x. Absence or inadequacy of first- aid box.</li> <li>xi. Misuse of first-aid box.</li> <li>xii. First-aid box not satisfy the minimum</li> <li>xiii. Smoking inside the construction site</li> </ul>	Rs.10,000 per single violation.  Compounded to a maximum of Rs.100,000 at any single instance.

Sl.No.	Topic	Unsafe Act/Unsafe Condition	Deductible Amount
		xiv. Drink and drive or work. xv. Excessive noise and vibration xvi. Canteen not provided xvii. Food stuff not served on no loss no profit basis. xviii. Creche not provided. xix. Accommodation not provided as per BOCWA xx. Fumigation / insecticides not sprayed to prevent Mosquito breeding xxi. Non-compliance of Clause 16(55.1 and 45.2)	
27.	Labour Welfare measures	<ul style="list-style-type: none"> <li>i. Non adherence of Labour welfare provisions of BOCWA</li> <li>ii. Fail to register establishment and display the registration certificate at workplace</li> <li>iii. Absence of workers register and records</li> <li>iv. Absence of muster roll and wages register</li> <li>v. Fail to display an abstract of BOCWA and BOCWR</li> </ul>	Rs.10,000 per single violation.  Compounded to a maximum of Rs.50,000 at any single instance.
28.	Environmental Management	i. Tire wash facility not provided ii. Spillage from vehicles not arrest iii. Air monitoring not practiced iv. Noise monitoring not practiced v. The values of air monitoring and noise monitoring not within acceptable limits vi. Dust control measures at sites not practiced vii. Improper disposal of debris/residues	Rs. 10,000 per single violation.  Compounded to a maximum of Rs.50,000 at any single instance.
29.	Working near exiting railway track	<ul style="list-style-type: none"> <li>i. To start work without erecting barricading as per requirement.</li> <li>ii. To start work in station area without permit to work or without approved plan.</li> <li>iii. To launch girder for RFO/ROB without approved plan and work permit.</li> <li>iv. Infringement of moving dimension by any vehicle / construction equipment with running train causing disruption of traffic, injury to passenger / fatal incidence.</li> </ul>	Rs. 500,000 for first violation and Rs.1,000,000 for subsequent violation.

72.1.4 Without limiting to the unsafe acts and or conditions mentioned above in Clause 16 (72.1.3) the Employer shall have the right to deduct charges for any other unsafe act and or condition depending upon the gravity of the situation on a case-to-case basis. The charges shall be in comparison with that of the similar offence indicated in Clause 16 (72.1.3).

### **73 STOPPAGE OF WORK**

73.1.1 The employer shall have the right to stop the work at his sole discretion, if in his opinion

the work is being carried out in such a way that it may cause accidents and endanger the safety of the persons and/or property and / or equipment. In such cases, the Contractor shall be informed in writing about the nature of hazards and possible injury/accident.

- 73.1.2 The Contractor shall not proceed with the work until he has complied with each direction to the satisfaction of Employer
- 73.1.3 The Contractor shall not be entitled for any damages/compensation for stoppage of work, due to safety reasons and the period of such stoppage of work shall not be taken as an extension of time for completion of the facilities and will not be the ground for waiver of levy of liquidated damages.

## **74 AWARDS**

- 74.1.1 The following categories will be considered for awards as per the scheme in practice of the Contractor.
- i. For every safe million man hour working without any reportable incidents.
  - ii. Zero fatality contracts.
  - iii. 100% adherence to voluntary reporting of all accidents throughout the currency of contract.
  - iv. Safest project team of the year.
  - v. Best SHE team of the year.
  - vi. Safest Contractor of the year.

## Attachments to Clause 16 [SHE Requirements] of Specifications

### ATTACHMENT 1

#### CONTENTS OF SHE PLAN

<b>SITE SHE PLAN</b>	
<b>Contract No.</b>	
<b>Contractor Name</b>	
<b>Project Name</b>	

<b>1</b>	<b>Project Highlights</b> <ul style="list-style-type: none"> <li>i. Title of the content</li> <li>ii. Contractor Number</li> <li>iii. Brief scope of work</li> <li>iv. Location map/ key plan</li> <li>v. Period of the project</li> </ul>
<b>2</b>	<b>SHE Policy</b>
<b>3</b>	<b>Site Organisation Chart</b> Chart indicating reporting of SHE personnel
<b>4</b>	<b>Roles &amp; Responsibility</b> Individual responsibility of the <ul style="list-style-type: none"> <li>i. Contractor's Representative</li> <li>ii. SHE Director</li> <li>iii. Chief Environmental Officer</li> <li>iv. Chief Accident Prevention Officer</li> <li>v. Construction Manager</li> <li>vi. Construction Supervisors</li> <li>vii. SHE Committee Members</li> <li>viii. SHE Incharge</li> <li>ix. Site Engineers</li> <li>x. First Line Supervisors</li> <li>xi. Sub-contractors</li> </ul>
<b>5</b>	<b>SHE Committee</b> <ul style="list-style-type: none"> <li>i. Details - Chairman, Members, Secretary and Engineer</li> <li>ii. Procedures for effective conduct of meeting</li> </ul>
<b>6</b>	<b>SHE Training</b>
<b>7</b>	<b>Sub-contractor Evaluation, Selection and Control</b>

<b>8</b>	<b>SHE Inspection</b>
<b>9</b>	<b>SHE Audit</b>
<b>10</b>	<b>Accident Investigation And Reporting Procedures</b>
<b>11</b>	<b>Occupational Health Measures</b>
<b>12</b>	<b>Labour Welfare Measures</b>
<b>13</b>	<b>Risk Assessment and Mitigation Procedures</b>
<b>14</b>	<b>Safe Work Procedures</b> <ul style="list-style-type: none"> <li>i. Work at Height</li> <li>ii. Structural Steel Erection</li> <li>iii. Launching of segments</li> <li>iv. Embankments and Cuttings</li> <li>v. Switch-over works</li> <li>vi. Bridges, ROBs, RUBs, Railway Flyovers</li> <li>vii. Works in close vicinity of railway tracks/ roads</li> <li>viii. Floor, Wall Openings and Stairways</li> <li>ix. Welding, Cutting and Bracing</li> <li>x. Lifting appliances</li> <li>xi. Work Permit Systems</li> <li>xii. Electrical Equipment</li> <li>xiii. Mechanical Equipment</li> <li>xiv. Excavation</li> <li>xv. Fire Prevention</li> <li>xvi. Hazardous Chemicals and Solvents</li> <li>xvii. Ionising Radiation</li> <li>xviii. Lighting</li> <li>xix. Abrasive Blasting</li> </ul>
<b>15</b>	<b>Work Permit System</b>
<b>16</b>	<b>List of standard job specific PPEs to be used in the site</b>
<b>17</b>	<b>Maintenance of Regime for construction Equipment and Machinery</b>
<b>18</b>	<b>Traffic Management</b>
<b>19</b>	<b>Housekeeping</b>
<b>20</b>	<b>Environmental and Social Management</b>
<b>21</b>	<b>Emergency Management</b>
<b>22</b>	<b>Visitors and Security arrangement</b>

**Note:** The Environmental and Social Management Plan (ESMP), the Environmental and Social Monitoring Plan (ESMoP), the Safety and Health Plan (SHP) and the Safety and Health Monitoring Plan (SHMoP) which supplement the SHE Plan shall be incorporated in the relevant sections.



## **ATTACHMENT 2**

### **CONTRACTOR'S ENVIRONMENTAL AND SOCIAL MANAGEMENT PLAN**

#### **1.General**

- 1.1 The Contractor shall prepare an Environmental and Social Management Plan (ESMP) setting out in detail how he proposes to manage and minimise the environmental and social impacts of his activities throughout the construction period.
- 1.2 The Contractor's ESMP shall be based on environmental and social considerations submitted with the Bid and shall have the content shown in the next section [Contents of ESMP].
- 1.3 The Contractor shall submit his ESMP for review by the Engineer within 42 days after the Commencement Date of the Services and shall amend the ESMP to address any comments made by the Engineer and submit a Final ESMP within 28 days of receipt of comments.
- 1.4 The Final ESMP shall be binding on the Contractor for the duration of the Services

#### **2.Contents of ESMP**

- 2.1 Contractor's Environmental Policy
  - 2.1.1 The first section of the ESMP shall contain a statement of the Contractor's intent with respect to the environment and the management of environmental and social impacts, which sets the framework for and guides, all other aspects of the plan.
- 2.2 Management Responsibility
  - 2.2.1 This section of the ESMP shall name the most senior manager in the contracting company or at their project site as having overall responsibility for environmental management, with an explanation of how that responsibility is delegated down to each level of management. It shall also name the Chief Environmental Officer (CENO) who is responsible for day-to-day environmental management, supervision and monitoring at all work-sites and has company authority to stop construction works if environmental non-compliance is observed.
  - 2.2.2 At each active construction site there must be at least one named person with delegated responsibility for environmental management on each shift. This person will be referred to as the Senior Environment Officer (SEO) and on larger sites he may be assisted by Environment Officer (EO), who will work under his direction conducting routine monitoring, data collection, etc.
  - 2.2.3 Environmental affairs include social issues and the ESMP must also identify a Community Liaison Officer (CLO) who will deal with community relations and liaise on behalf of the Contractor with people who may be affected by the construction process. The CLO shall integrate all of his activities with those of other social specialists responsible for supporting the Resettlement and Rehabilitation Plan (RRP) for the project for the Employer and shall operate within the framework of the Entitlement Matrix and Grievance Redress Procedure established by the RRP.
- 2.3 Management Contact
  - 2.3.1 The office and home telephone or radio contacts (including mobile / cell phone contact) shall be listed for all named persons having environmental management responsibility.

## 2.4 Mitigation Measures

2.4.1 The Contractor shall deal in turn with each of the mitigation measures identified as his responsibility in the S-ESIMMS for the project (JICA 2009) and explain in detail how he proposes to provide the mitigation as specified in the Clause 16 [SHE Requirements] of Specifications.

2.4.2 This should not simply repeat the contents from the Clause 16 [SHE Requirements] of Specifications but shall explain in detail: a) the action or series of actions the Contractor will take to comply with each clause or sub-clause; b) responsibility for each action; c) the programme for each action; d) how the Contractor proposes to monitor the provision and effects of each action and e) parameters or performance indicators to be monitored.

## 2.5 General Environmental Management

2.5.1 The Contractor shall identify and describe the more general actions he proposes to take to manage and mitigate the environmental and social impacts of his day-to-day operations. These shall be presented and explained in the same way as the specified mitigation measures, as in Clause 2.4.2 (a-e).

2.5.2 Actions shall include, but not be limited to, those specified in Clause 2.5.3 to 2.5.5 (any items that are adequately covered in Section 2.4 need not be repeated).

### 2.5.3 Construction Site Management

General environmental management at construction sites shall include at least the following:

- Dedicated concrete-floored areas for vehicle maintenance, from which all drainage passes through an oil/water separator and sediment trap;
- Dedicated concrete-floored areas for vehicle washing, also with drainage via an oil/water separator and sediment trap;
- Storage of all liquid fuel, lubricants and other toxic liquids in concrete-floored and bunded areas, the volume of which is at least equivalent to that of all stored liquids;
- Watering of site roads and other exposed soil during the dry season to suppress dust, with water tankers permanently available for this purpose;
- Collection of drainage at all sites and passage into settlement tanks/sediment traps before discharge;
- Treatment of all sewage and any other liquid discharges to national effluent standards and/or consent conditions before discharge;
- All point-source atmospheric emissions (e.g. from crushers, batching plants, engines, generators, etc) shall comply with national standards or international standards if a national standard is not available;
- All motor-driven generators, compressors, pumps, etc. to be properly silenced to suppress noise to national standards or international standards if a national standard is not available;
- Site lighting and use of machinery near inhabited areas to be limited to normal daytime working hours;
- Disposal of solid waste by arrangement with local municipalities;
- No use or disposal of nationally or internationally proscribed toxic and hazardous substances;
- Issuance of a Code of Practice to all workers, specifying required behaviour, including but not limited to :
  - No hunting, fishing, timber collection or lighting of fires;
  - No discarding of litter or other waste;
  - Proper usage of toilets and washrooms;

- Other behaviour to comply with defined local cultural and religious sensitivities;
- No unauthorised entry onto private property;
- Immediate dismissal for any transgression.

#### 2.5.4 Management of Land

Preparation, use and after-care of land shall include at least the following:

- Conservation of topsoil during vegetation removal and disposal of cut vegetation by composting to the extent possible and provision of wood/timber to local communities free of charge;
- Disposal of any remaining vegetation at managed sites, without burning;
- Removal of topsoil before excavation and storage for future use, with measures to prevent erosion or dust production from stockpiles;
- Prior recording of the location of all walls, fences and other structures on temporarily acquired land, so that they may be replaced at the end of construction;
- Reinstatement of all temporarily acquired land after use to its pre-construction condition or as otherwise reasonably required by the owner;
- Detailed planning of cut and fill volumes to maximise the re-use of material in the project and minimise the disposal of spoil, with excess spoil being deposited at planned disposal sites only;
- Adoption of a precautionary approach towards the risk of uncovering archaeological material, by: a) avoiding any work within the boundaries of scheduled monuments and sites. Work outside the extended boundary as per rules. If required to work within the boundary, necessary permission from authority shall be in place; b) obtaining an expert assessment of the risk of finding material at non-scheduled sites; c) having excavation in high-risk sites observed by qualified archaeologists; d) training workers and digger operatives to recognise archaeological material and e) halting work if any finds are suspected.

#### 2.5.5 Community Liaison and Facilities

The Contractor shall establish regular contact with communities local to all construction sites for the purposes of exchanging information and developing mutual understanding. Such contacts shall include:

- Consulting all communities in the vicinity of construction sites prior to commencement of any work (via the CLO and other staff as necessary), to inform them of the work proposed, construction programmes and measures to maintain safety and minimise disruption and disturbance; all such contacts shall be coordinated with the Employer's ongoing programme of community liaison;
- Identification via the consultation process of any important community features, which the Contractor shall make arrangements to conserve or remove/relocate with community agreement, at his own expense;
- Protecting features to be retained (cemeteries, buildings, etc) by secure fences, fluorescent tapes and appropriate signs;
- Clear marking of excavated areas near settlements with posts, fluorescent tapes and warning signs;
- Providing suitable temporary bridges or diversions wherever existing roads, tracks or footpaths are intersected by construction works;
- Providing temporary potable water supplies if access to the existing water supply is interrupted at any time.
- Barricading of excavated sites near settlement

## 2.6 Training

2.6.1 The Contractor shall describe the training programme and content he will provide for workers and staff in order to:

- Raise awareness of: the role and importance of environmental matters both globally and locally; the potential negative impacts of construction work in general and the ways in which impacts can be mitigated and the expected construction impacts and long-term environmental and social benefits of the DFC project;
- Disseminate the philosophy and approach of the ESMP to environmental protection throughout the workforce and explain the roles of all parties in implementing the mitigation and environmental safeguard measures;
- Inform all employees of the mitigation and environmental protection measures they are required to comply with when conducting their work and the penalties for non-compliance.

2.6.2 Training to raise the awareness and capacity of sub-contractors and their employees shall also be incorporated where necessary.

2.7 Appendices

2.7.1 The ESMP shall contain components of the mitigation measures specified above and in Clause 16 [SHE Requirements] of Specifications. The contents of the plan shall include, but not be limited to, the items listed:

2.7.2 The Contractor shall prepare the following plans to supplement the ESMP.

- Stockpile Area Management Plan
- Site Drainage and Flood Prevention Plan
- Accommodation Camp Management Plan
- Borrow Pit and Quarry Site Management Plan
- Construction Water and Rain Water Harvesting Plan
- Pollution Prevention and Control Plan (air, water, noise, vibration, etc.) with Noise Monitoring and Control Plan
- Solid Waste Management Plan
- Physical Cultural Resources Management Plan
- Site Rehabilitation Plan

### **3.ESMP Implementation**

3.1 The Contractor's ESMP shall be implemented within the framework of a company Environmental Management System (EMS), which is certified to ISO 14001-2004, or is scheduled to be so certified within the timescale of this project.

3.2 Each organization sub-contracted by the Contractor shall prepare their own daughter ESMP, which follow the format specified in "2 Contents of ESMP" above. This applies to all sub-contractors and major suppliers, whether or not they are working on-site. The Contractor shall provide guidelines on ESM to its other vendors viz. transport contractors, waste management contractors, quarry companies, material merchants, fuel suppliers etc. describing how they will manage and minimise the environmental and social impacts of their activities related to this project. The sub-contractor's ESMP should be integrated into the Contractor's ESMP

3.3 The ESMP shall be brought to the attention of all employees engaged in construction or supporting activities and they shall be given training in those aspects of the ESMP that relate to their work and an insight into the potential adverse impacts of their work and how they are to be mitigated.

## ATTACHMENT 3

### **CONTRACTOR'S ENVIRONMENTAL AND SOCIAL MONITORING PLAN**

#### **1.General**

- 1.1 The Contractor shall prepare an Environmental and Social Monitoring Plan (ESMoP) setting out the details of the monitoring to conduct in order to:
  - a. Ensure that each environmental mitigation measure that is his responsibility is provided as specified in section 2.4 of his ESMP;
  - b. Ensure that each environmental management measure is implemented as proposed in section 2.5 of his ESMP;
  - c. Ensure he complies with the requirements of all relevant national and state legislation and any consent conditions applied by government competent authorities;
  - d. Determine whether each mitigation and management measure is protecting the environment as intended and
  - e. Detect any additional environmental impacts that may occur, for which additional mitigation may be needed.
- 1.2 The Contractor shall submit his ESMoP for review by the Engineer within 42 days after the Commencement Date of the Services and shall amend the ESMoP to address any comments made by the Engineer and submit a Final ESMoP within 28 days of receipt of comments.
- 1.3 The Final ESMoP shall be binding on the Contractor for the duration of the Services

#### **2.Content of ESMoP**

- 2.1 Monitoring described in the ESMoP shall cover all areas that could be affected by the construction work, including all construction sites and their surroundings, plus off-site areas and locations operated by sub-contractors, such as quarries, transportation routes, waste disposal sites.
- 2.2 Monitoring shall be conducted at specified regular intervals throughout the entire construction period.
- 2.3 The Contractor shall be solely responsible for conducting the monitoring described in his ESMoP and for ensuring that data collected are scientifically robust and credible.
- 2.4 The ESMoP shall describe each monitoring procedure in detail, including (as relevant):
  - Purpose;
  - Equipment and specifications;
  - Calibration procedure;
  - Monitoring locations, parameters, frequency and duration;
  - Monitoring methodology;
  - Data presentation and analysis.
- 2.5 The monitoring shall include, but not necessarily be limited to, the items listed below
- 2.6 The most frequent monitoring activity shall involve inspection and observation on a daily basis to determine compliance with the mitigation measures described in section 2.4 of the Contractor's ESMP.
- 2.7 Daily inspection and observation shall also be conducted to determine compliance with the management measures specified in section 2.5 of the Contractor's ESMP, relating to

- construction site management, accommodation camp management, solid and toxic waste management, management of land, transport management, community liaison and facilities and health and safety etc.
- 2.8 The Contractor shall also conduct regular formal monitoring of environmental quality parameters (including air quality, noise and water quality) as proposed by the S-ESIMMS (JICA 2009) to determine the impacts of the ongoing construction work and to record compliance with legally prescribed standards.
- 2.9 Additional inspection or monitoring shall be conducted as may be specified by government competent authorities in consent conditions or other approvals obtained by the Contractor.
- 2.10 Additional “spot” monitoring shall be conducted whenever non-compliance is observed, or if a complaint is received from a member of the public, organisation or a government body.

### **3.ESMoP Implementation**

- 3.1 Monitoring activities shall be conducted by the Contractor's employees, or specialist sub-contractors employed by him and all persons involved in the monitoring procedures shall be suitably qualified and experienced. Engineer's representative may also join if he so desires
- 3.2 Monitoring at each construction site shall planned and supervised by the Contractor's Senior Environment Officer at that site and overall implementation of the ESMoP across all sites shall be planned and coordinated by the Contractor's CEO.
- 3.3 The results of the monitoring shall be regularly reported to the Engineer and Employer.

## ATTACHMENT 4

### CONTRACTOR'S SAFETY AND HEALTH PLAN

#### 1. General

- 1.1 The Contractor shall prepare a Safety and Health Plan (SHP), which provides measures to protect the safety and health of employees at all times when engaged in the construction process and the general public when exposed to construction activities either on- or off-site.
- 1.2 The Contractor's SHP shall be based on safety and health considerations submitted with the Bid and shall have the content shown in the next section [Contents of SHP].
- 1.3 The Contractor shall submit his SHP for review by the Engineer within 42 days after the Commencement Date of the Services and shall amend the SHP to address any comments made by the Engineer and submit a Final SHP within 28 days of receipt of comments.
- 1.4 The Final SHP shall be binding on the Contractor for the duration of the Services

#### 2. Content of SHP

- 2.1 The Contractor's SHP shall cover the following aspects
  - (a) Statement of Contractor's Safety and Health Policy
  - (b) Senior management responsibility for safety and health
  - (c) Appointment, duties and responsibilities of site safety and health staff
  - (d) Policy for identifying hazards and risks
  - (e) Safety and health training
  - (f) Safety and health equipment
  - (g) Safety and health of the Contractor's construction and office equipment
  - (h) Safety and health of the workmen and staff at site
  - (i) Safety and health procedures for sub-contractors
  - (j) Disciplinary procedures
  - (k) Accident, disease and injury reporting
  - (l) First aid and emergencies
  - (m) Safety and health promotion and awareness
  - (n) Site security
  - (o) Labour safety and health
- 2.2 The Contractor's SHP shall also incorporate the requirements of safety while having interface with the running tracks of Indian Railways and complying with
  - (a) Indian Railway's rules and regulations for track, signalling and operations possessions
  - (b) operating a system of permit to work for all works which may affect the operations of the existing railway and
  - (c) requirements of safety aspects for working near the running tracks of Indian Railways as

specified herein below

- 2.3 The Engineer reserves the right to order (in writing) the immediate removal and replacement of any of the Contractor's equipment or temporary works which in his opinion is unsatisfactory or not required for the Work for its purpose and / or is in unsafe condition, while the Contractor shall be fully responsible for safety of the Works and shall treat safety measures as a priority in all his activities throughout the execution of the Works. The following requirements shall be also incorporated in the SHP, but not limited to;
- 2.3.1 The Contractor shall have full regard for the safety and health of all his personnel, sub-contractor's personnel, the public and all the personnel directly or indirectly associated with the Works on or in the vicinity of the Site and the Work Areas (including without limitation to the persons to whom access to the Site has been allowed by the Contractor), to comply with all relevant safety and health regulations, including provision of safety and health gear and insofar as the Contractor is in occupation or otherwise is using areas of the Site and the Work Areas, to keep the Site and the Work Areas (so far as the same are not completed and occupied by the Employer) in an orderly state appropriate to the avoidance of injury to all persons and shall keep the Engineer/ Employer indemnified against all the injuries to such persons.
- 2.3.2 The Contractor shall provide and maintain all lights, guards, fences and warning signs and watchmen when and where necessary or required by the Engineer or by laws or by any relevant authority for the protection of the Works and for the safety and convenience of the public and all persons on or in the vicinity of the Site and the Work Areas.
- 2.3.3 The Contractor is required to take note of all the necessary provisions in Clause 16 [SHE Requirements] of Specifications and the Contract Price shall be deemed to be inclusive of all the necessary costs to meet the requirements as prescribed therein. In case the Contractor fails to meet the above requirements, the Employer may provide the necessary arrangements and recover its costs from any bills due to the Contractor.

### 3 Training

- 3.1 The Contractor shall describe the training programme and content he will provide for workers and staff in order to:
- Raise awareness of: the role and importance of safety and health matters; the potential negative impacts of construction work in general and the ways in which impacts can be prevented and the expected construction impacts and long-term environmental and social benefits of the DFC project;
  - Disseminate the philosophy and approach of the SHP throughout the workforce and explain the roles of all parties in implementing the SHP;
  - Inform all employees of the safety and health activities they are required to comply with when conducting their work and the penalties for non-compliance.
- 3.2 Training to raise the awareness and capacity of sub-contractors and their employees shall also be incorporated where necessary.

### 4 Appendix

- 4.1 The SHP shall contain components of the mitigation measures specified above and in Clause 16 [SHE Requirements] of Specifications. The contents of the plan shall include, but not be limited to, the items listed:
- 4.2 The Contractor shall prepare the following plans to supplement the SHP
- Emergency Response Plan
  - Fire Evacuation Plan



## ATTACHMENT 5

### **SAFETY REQUIREMENTS FOR WORKING NEAR RUNNING TRACKS OF INDIAN RAILWAYS**

#### **1. Operational Safety**

1.1 Where the Schedule of Dimensions of Indian Railways (IR) for the running tracks are likely to be infringed by the Contractor, the following safety measures shall be ensured

##### 1.1.1 Measures Prior to Start of the Work

- (i) Contractor to provide necessary training to their supervisors and staff and shall ensure that they know about the safety norms to be followed for working in the premises of IR and in the vicinity of running tracks and electrified territories
- (ii) Inform the Engineer / Employer about :
  - (a) Name and address of the Contractor's supplier / sub-contractor assigned to execute the work
  - (b) Name of the vehicle drivers / equipment operators identified for the work
  - (c) Location, duration and timings during which the SOD of IR is to be infringed
- (iii) Provide the Engineer / Employer with
  - (a) copy of detailed planning of work including protection of IR track and safety measures proposed (duly approved by the Engineer)
  - (b) copy of the competency certificate of the Contractor's Supervisor incharge of the work (to be issued by the Engineer)
- (iv) Demarcate the working area at site in consultation with the Engineer / Employer
- (v) Barricade / temporary fencing along the stretch of the concentration of the work area along the IR track, as consented by the Engineer
- (vi) Provide adequate watch and ward, flagmen, lighting etc. including signage boards

##### 1.1.2 Measures during Execution of Work

- (i) It shall be ensured that no workmen and staff is working on line / trackside unless proper 'Permit to Work' is issued for those lines by the Indian Railways and Engineer.
- (ii) It shall be ensured that the moving dimensions of IR shall not be infringed. In case of track crossing, the work is required, the same shall not be carried out without permission from the Engineer and IR. Safety of all the existing fixed structures near the vicinity of the Site shall also be ensured.
- (iii) No vehicles shall be plied within 6m of centre of the IR track without the specific approval from Engineer / Employer. Individual vehicle / construction equipment shall not be left unattended. No vehicle shall ply from sun-set to sunrise and during the period when the visibility is impaired, except in case of emergency and with the consent of the Engineer
- (iv) Where the construction vehicles are required to ply along the existing running tracks of IR, the Contractor shall deploy the adequate patrolmen to prevent tendency of the vehicle

drivers to come close to the tracks and infringe

- (v) All the drivers of the road vehicles / machines plying near the running tracks of IR shall be provided with a red flag / red lamp so that in the event of any obstruction, they can stop the incoming train,
- (vi) It shall be ensured that the line of demarcation shall not be infringed by the road vehicles / construction equipment
- (vii) It shall be ensured that only eligible and competent staff shall be employed for the work and they must wear identity card while working near running tracks of IR
- (viii) For working during night, sufficient illumination shall be provided for the entire work area for safety of the workmen and public
- (ix) Temporary Engineering signals as required shall be provided
- (x) Existing engineering indicator boards shall be lit as per Permanent Way Manual (PWM) of Indian Railways.
- (xi) Lookout man with red and green flags / hand signals and whistle shall be deployed wherever required
- (xii) No part of the stacked material should infringe the moving dimensions of IR. Material shall be stacked to such a height that it does not lead to infringement of SOD in case of accidental toll off.
- (xiii) Any temporary arrangement shall not infringe with the moving dimensions of IR
- (xiv) Where the work is planned to be done within 3.5m from the centre of the IR tracks, it shall require traffic block and all the necessary safety precautions shall be ensured as per the requirements of Para No. 806 and 807 of PWM of Indian Railways.
- (xv) First aid kit shall be readily available at the site
- (xvi) In case any cable / utility is found while working, the Contractor shall inform the Engineer immediately. In case a large number of cables / utilities are found during excavation, the work shall be carried out in the presence of representative from the concerned owning agency of the utility / cable.
- (xvii) It shall be ensured that the existing emergency sockets of IR are not damaged

#### 1.1.3 Additional Measures Required during Traffic Block

- (i) Any work when infringing the moving dimensions of IR shall be started only after traffic block has been imposed and IR track is protected
- (ii) All the work intended to be completed during traffic block shall be completed within the duration of the traffic block and the duration of the traffic block shall not be exceeded.
- (iii) Traffic block shall be considered as cleared only when all the temporary arrangements / machinery are cleared of the moving dimensions and the IR track is left with proper track geometry so that IR trains can run safely.

#### 1.1.4 Safety Measures while Working in OHE Area

- (i) While working near the OHE area, the safety guidelines as specified in para 20301, 20327, 20334, 20335, 20529, 20612, 20614, 20714, 20825, 20833, 21206 and 21207 of Volume II, Part 1 of AC Traction Manual of Indian Railways shall be followed

- (ii) No electric work close to the live OHE shall be carried out without power block and specific approval from Engineer / Employer
- (iii) A minimum distance of 2m shall be maintained between live OHE wire and any body part of the workmen or tools or metallic support etc.
- (iv) No electric connection shall be tapped from OHE

## **2. Excavation Affecting Existing Tracks**

2.1 While doing excavation near the vicinity of the existing tracks including for bridges and other structures, special care has to be taken to ensure that formation of the existing Railway line is not excavated, for that matter any activity involved in construction / execution of the project shall not endanger the safety of existing running line of Indian Railways. If excavation or any other activity involving working and or modification and or alteration of the existing permanent way then, before execution of such work, the Contractor shall prepare a drawing clearly indicating such alternation / modification of the existing permanent way and the protection measure intended to be taken by the Contractor to ensure safety of the existing running line. The effectiveness of design of such protection measures is the sole responsibility of the Contractor and the Contractor shall indemnify the Engineer / Employer towards the losses incurred due to failure of such protection measure. These protection measures duly indicating the extent of alternation / modification to the existing formation shall be incorporated in the design and drawing submitted during preliminary design submission as per the Contract. Such work shall not be undertaken unless and until these drawings are consented by the Engineer.

2.2 The Contractor shall indemnify the Engineer / Employer against any damage to the existing tracks / structures / utilities etc. caused by the actions of the Contractor or his sub-contractors and shall make good the same, as directed by the concerned authorities, at his own cost and shall also pay any penalty(ies) / demurrages if levied by the concerned authorities.

## **3. Safety Requirements for Electrical Works**

- (a) The Indian Electricity Rules 1956, as amended up to date, shall be followed. The detailed instructions on safety procedures given in I.S.S. and Indian Electricity Rules, respective State Electricity Authorities' regulation with up to date amendment shall be applicable.
- (b) The LT/HT distribution diagrams of sub stations shall be prominently displayed. The substation premises, main switch rooms and D.B. enclosure shall be kept clean whenever works are carried either inside or outside.
- (c) No inflammable materials shall be stored in places other than the rooms specially constructed for this purpose in accordance with the provisions of Indian Explosives Act
- (d) Rubber insulating mats of suitable size and thickness should be provided in front of the main switch boards of sub-station or any other control equipment of medium voltage and above
- (e) Protective and safety equipment such as rubber gauntlets or gloves, earthing rods, linemen's belt, portable artificial respiration apparatus, safety goggles etc., shall be provided as per the requirement of the Work
- (f) Necessary number of caution boards such as "Man working on line, Don't switch on" shall be readily available in the vicinity of electrical installation
- (g) Standard first aid boxes containing materials as prescribed by the St. John's Ambulance Brigade or Indian Red Cross shall be made available

- (h) Charts displaying methods of giving artificial respiration to a recipient of electrical shock (one in English and another one in the regional language) shall be prominently displayed at appropriate places
- (i) No work shall be undertaken on live installations, or on installation, which could be energized unless one another person is present to immediately isolate the electric supply in case of any accident and to render first aid, if necessary
- (j) No work on live L.T. bus bar or pedestal switch board in the sub stations should be handled by a person below the rank of a Licensed Wireman and such a work should preferably be done in the presence of a qualified engineer
- (k) When working on or near live installations, suitable insulated tool should be used and special care should be taken to see that those tools accidentally do not drop on live terminals causing shock or dead short.
- (l) The electrical switch controls in distribution boards shall be clearly marked to indicate the areas being controlled by them
- (m) Before starting any work on the existing installation, it shall be ensured that the electric supply to that portion is cut off. Precautions, like displaying "Men at Work" caution boards on the controlling switches, removing fuse carrier from these switches shall be taken against accidental operation. Caution boards shall be kept with the person working on the installation,
- (n) All electrical panels & switchgear shall conform to relevant IEC standard.
- (o) All external enclosures shall have degree of protection not less than IP-54
- (p) All equipment/system shall conform to relevant IEC standard on Electromagnetic Compatibility (EMC).
- (q) Cable routes of all the newly laid cables by the Contractor shall be identified with electronic or concrete markers.

## ATTACHMENT 6

# SAFETY, WELFARE AND OCCUPATIONAL HEALTH REQUIREMENTS

### Safety, Welfare and Occupational Health Requirements as per BOCW Act 1996 and BOCW Rules 1998

(This list has been prepared in chronological order with primary importance to Section of Act and secondary importance to Rules)

S -Refers relevant Sections in BOCWA

R -Refers relevant Rules in BOCWR

C -Refers relevant Chapter No. in BOCWR

Sl. No.	Items / Requirements	Relevant Sections / Rules in BOCWA and BOCWR
1.	Registration of establishment	S – 7, R – 23 to 27
2.	Display of registration certification at workplace	R – 26 (5)
3.	Hours of work	S – 28 R – 234 to 237
4.	Register of overtime	S – 28; S – 29 R – 241(1) Form XXII
5.	Weekly rest and payment at rest	R – 235
6.	Night shift	R – 236
7.	Maintenance of workers registers and records	S – 30 R – 238
8.	Notice of commencement and completion	S – 46 R – 239
9.	Register of persons employed as building workers	R – 240
10.	Muster roll and wages register	R – 241(1) (a); Form XVI and XVII
11.	Payment of wages	R – 248
12.	Display of notice of wages regarding	R – 249

13.	Register of damage or loss	R – 241(1)(a); Form XIX, XX, XXI
14.	Issue of wages book	R – 241(2)(a); Form XXIII
15.	Service certificate for each workers	R – 241(2)(b); Form XXIV
16.	Display an abstract of BOCWA and BOCWR	R – 241(5)
17.	Annual return	R – 242; Form XXV
18.	Drinking water	S – 32
19.	Latrines and Urinals	S – 33 R - 243
20.	Accommodation	S – 34
21.	Creches	S – 35
22.	First-aid boxes	S – 36 R – 231 and Schedule III
23.	Canteens	S – 37; R – 244
24.	Food stuff and other items served in the canteens	R – 245
25.	Supply of tea and snacks in work place	R – 246
26.	Food charges on no loss no profit basis	R - 247
27.	Safety committee	S – 38 R – 208
28.	Safety officer	S – 38 R – 209 and Schedule VII
29.	Reporting of accidents and dangerous occurrences	S – 39 R – 210
30.	Procedure for inquiry in to the causes of accidents	R – 211
31.	Responsibility of employer	S – 44; R – 5
32.	Responsibility of Architects, Project engineer and Designers	R – 6
33.	Responsibility of workmen	R – 8
34.	Responsibility for payment of wages and compensation	S – 45
35.	Penalties and Procedures	S – 47; S – 55
36.	Excessive noise, vibration etc	R – 34
37.	Fire Protection	R – 35
38.	Emergency action plan	R – 36
39.	Fencing of motors	R – 37
40.	Lifting of carrying of excessive weight	R – 38
41.	Health, Safety and Environmental Policy	R – 39

42.	Dangerous and Harmful Environment	R – 40
43.	Overhead protection	R – 41
44.	Slipping, Tripping, Cutting, Drowning AND Falling Hazards	R – 42
45.	Dust, Gases, Fumes, etc.	R – 43
46.	Corrosive substance	R – 49
47.	Eye Protection	R – 45
48.	Head Protection and other protection apparel	R – 46; R – 54
49.	Electrical Hazards	R – 47
50.	Vehicular traffic	R – 48
51.	Stability of structure	R – 49
52.	Illumination	R – 50; R – 124
53.	Stacking of materials	R – 51
54.	Disposal of debris	R – 52
55.	Numbering and marking of floors	R – 53
56.	Lifting appliances and gears	C – VII; R – 55 to 81
57.	Runways and Ramps	C – VIII; R – 82 to 85
58.	Working on or adjacent to water	C – IX; R – 86 & 87
59.	Transport and earthmoving equipment	C – X; R – 88 to 95
60.	Concrete work	C – XI; R – 96 to 107
61.	Demolition	C – XII; R – 108 to 118
62.	Excavation and Tunnelling works	C – XIII; R – 119 to 168
63.	Ventilation	R – 153
64.	Construction, repair and maintenance of step roof	C – XIV; R – 169 to 171
65.	Ladders and Step ladders	C – XV; R – 172 to 174
66.	Catch platform and hoardings, chutes, safety belts and nets	C – XVI; R – 175 to 180
67.	Structural frame and formworks	C – XVII; R – 181 to 185
68.	Stacking and unstacking	C – XVIII; R – 186 & 187
69.	Scaffold	C – XIX; R – 188 to 205
70.	Cofferdams and Caissons	C – XX; R – 206 to 211
71.	Explosives	C – XXI; R – 212 & 213
72.	Piling	C – XXII; R – 214 to 222
73.	Medical Examination for building and other construction worker, Crane operator an Transport vehicle drivers	R – 81; R – 223(a)(iii) and Schedule XII
74.	Medical examination for occupational health hazards	R – 233(a)(iv)

75.	Charging of workers for Medical Examination	R – 223(b)
76.	Occupational health centres and Medical officers	R – 225 and Schedule X & XI
77.	Ambulance van & room	R – 226 & 227 and Schedule IV & V
78.	Stretchers	R – 228
79.	Occupational health service for building workers	R – 229
80.	Medical examination for occupational health hazards	R – 223(a)(iv)
81.	Emergency care services & emergency treatment	R – 232
82.	Panel of experts and agencies	Central Rule 250
83.	Power of inspectors	Central Rule 251



## **ATTACHMENT 7**

### **WORK PLACE POLICY ON LABOUR PROTECTION**

#### **DFCCIL's WORKPLACE POLICY ON LABOUR PROTECTION**

##### **CHAPTER - I Perspectives**

###### **1.0 Preamble**

DFCCIL believes that all its employees including the employees of contractors, subcontractors or consultants must live with social and economic dignity and freedom, regardless of nationality, gender, race, economic status or religion.

Further, DFCCIL is committed to the principles of:

- a) No child or forced labour in its operations.
- b) Discrimination free workplace.
- c) Gender Equity.
- d) Supportive work environment.

DFCCIL intends to evolve a workplace policy on labour protection for the employees and workers of contractors, subcontractors and consultants upholding the rights of citizens enshrined in The Constitution of India, principles laid down in the Directive Principles of State Policy and the statutory provisions contained under applicable laws relating to employment and service conditions of labour, their welfare, occupational health and safety.

###### **2.0 Aim**

The policy aims to:

- a) Provide a statutory framework on employment and service conditions of labour, their welfare, occupational health and safety.
- b) Design suitable control systems of compliance, enforcement and incentives for better compliance;
- c) Provide administrative and technical support services;
- d) Provide a system of incentives to contractors and their employees to achieve higher health and safety standards;
- e) Provide for a system of non-financial incentives for improvement in safety and health;
- f) Provide for a system of penalties if provisions on safety, health and employee welfare are not adhered to.

###### **3.0 Objectives**

The basic objectives of this Workplace Policy on Labour Protection are:

- a) To promote a just, free and humane workplace ambience;
- b) To ensure safe and healthy working conditions;
- c) To eliminate the incidence of work related injuries, diseases, fatalities, disaster and loss of national resources;
- d) To ensure a high level of occupational health and safety and conditions of labour through proactive approaches including a system of penalties and awards;
- e) To enhance the well-being of the employees and their family members.

#### **4.0 Scope**

This policy applies to all contractors, subcontractors, consultants and their employees (including candidates applying to them for work) in the work sites, office locations, accommodation camps, all other workplaces and contracts of employment and all aspects of work, formal and informal and the self-employed worker engaged with the Contractor for providing goods or services at any work location and their spouse and children or other family members, residing in contractor provided accommodation with the worker.

#### **5.0 Framework**

This policy and guidelines of action plan is based on the framework as given below:

##### **5.1 Laws and Regulations:**

The Contractor shall fully comply with the applicable labour laws as amended from time to time and the rules framed there-under as given in Clause 16 [SHE Requirements] of Specifications (Volume III of Bid Documents) and this policy.

##### **5.2 Policy and Manual for Safety and Health:**

The Contractor shall promote safe and healthy working practices and adhere to the norms given in Clause 16 [SHE Requirements] of Specifications (Volume III of Bid Documents).

##### **5.3 Contractor's Policy and plan for Safety and Health:**

The Contractor shall submit policy and plan for health and safety which shall include the stipulations made in Clause 16 [SHE Requirements] of Specifications.

##### **5.4 Design and Method Statement:**

The Contractor shall prepare the method statements for construction based on the design that shall include measures and methods for dealing with the risks in construction within the period stipulated in the Bid Documents.

##### **5.5 Safety and Health on Site:**

The Contractor shall develop the regulations for SHE committee to be established in terms of the requirements given in Clause 16 [SHE Requirements] of Specifications.

The Contractor shall also develop the regulation for the site inspection and monitoring compliance of safety and health norms.

#### 5.6 Prevention and Control of HIV/AIDS:

The Contractor shall prepare a manual for HIV/AIDS prevention and control for his workers in terms of the Employer's policy and submit the same for Employer's approval within the period stipulated in the Clause 16 [SHE Requirements] of Specifications.

### 6.0 Coverage

6.1 The coverage of this policy shall be as under:

- a) Conditions of employment;
- b) Salary and Wages;
- c) Social Security;
- d) Occupational Health and Welfare;
- e) Compliance with Labour Laws;
- f) Implementation and monitoring.

### 7.0 Awareness

7.1 The Contractor shall create awareness about this policy by:

- a) Wide circulation among his key officials, subcontractors and consultants;
- b) Display in notice boards at conspicuous places;
- c) Increasing awareness on safety, health and environment at the workplace through appropriate means;
- d) Providing forums for consultations with employees representatives on matters relating to occupational safety, health and welfare and wherever necessary with the community on matters of societal concerns with the objective of increasing productivity;
- e) Encouraging joint labour-management efforts to preserve, protect and promote national assets and to eliminate injuries and diseases arising out of employment;
- f) Providing medical criteria wherever necessary to ensure as far as is reasonably practicable that no employee will suffer diminished health, functional capacity, or life expectancy as a result of his work place activities and that in the event of such occupational diseases having been contracted, the affected employee is suitably compensated;
- g) Taking necessary steps to provide safe and healthy working conditions and ensure that workers and their representatives are consulted, trained, informed and involved in all measures related to their safety and health at work;

## **8.0 Occupational Safety and Health Skills Development**

8.1 The Contractor shall:

- a) Arrange training programmes to increase the number and competence of personnel engaged in the field of occupational safety and health and environment at workplace;
- b) Provide information and advice, in an appropriate manner, to employees with a view to eliminating hazards or reducing them as far as is reasonably practicable;
- c) Establish occupational health services aimed at protection and promotion of health of employee and improvement of working conditions and by providing employee access to these services.
- d) Integrate health and safety into vocational, professional and labour related training programmes including management development programmes;
- e) Adopt Occupational Safety and Health training curricula in workplace programmes.

## **9.0 Miscellaneous**

- 9.1 The Contractor shall comply with the applicable labour laws and the rules framed there under by Central or State Governments as amended and/or modified from time to time.
- 9.2 Consequences and or penalties arising out of violation of the applicable laws shall be the sole responsibility of contractors.
- 9.3 The policy shall also be periodically reviewed by the Employer with reference to the evolving legislation, scope and programme of the work, ambient conditions, etc. and the Contractor shall incorporate the requisite modifications in execution of the work without any extra charges.

## **10.0 Conclusion**

There is a need to develop close involvement of social partners to meet the challenges ahead in the assessment and control of workplace risks by mobilising local resources and extending protection to such working population and vulnerable groPSS where social protection is not adequate.

DFCCIL stands committed to strengthen the labour protection mechanism through broad-based consultation, develop special programmes for hazardous operations, set up training mechanisms, create awareness, arrange for the mobilisation of available resources and expertise.

This policy envisages total commitment and demonstration by all concerned stake holders through dedicated and concerted efforts consistent with the requirements of labour protection at workplace and thereby improving the quality of work and working life.

The policy shall be periodically reviewed by the Employer with reference to the evolving legislation, scope and programme of the work, ambient conditions, etc. and the Contractor shall

incorporate the requisite modifications in execution of the work without any extra charges.

## CHAPTER-II

### CONDITIONS OF EMPLOYMENT

- 1.0 The Contractor shall engage appropriate staff and labour, local or otherwise to enable him to completely fulfil all his obligations under the contract.
- 1.1 The Contractor shall devise or should already have service rules defining the conditions of employment of the staff and workers employed by them in the project of DFCCIL.
- 1.2 The service rules shall contain the following provisions:
  - a) Classification of workers, e.g., whether permanent, temporary, apprentices, probationers, substitute or casual.
  - b) Intimation of periods and hours of work, holidays, paydays and wage rates to the workmen.
  - c) Shift working.
  - d) Attendance and late coming.
  - e) Procedure for applying for grant of leaves and holidays, specifying the sanctioning authority and conditions thereof.
  - f) Requirement to enter premises by certain gates and liability to search.
  - g) Closing and reopening of sections of the industrial establishment and temporary stoppages of work and the rights and liabilities of the Employer and workmen arising there-from.
  - h) Termination of employment and the notice thereof to be given by Employer and workers.
  - i) Suspension or dismissal for misconduct and acts or omissions which constitute misconduct.
  - j) Means of redress available to workers against unfair treatment or wrongful exactions by their employer or his agents or servants.
- 1.4 The conditions of employment to be contained in the above mentioned service rules shall not be inferior to the provisions contained in the model standing orders given as Schedule-I of Industrial Employment (Standing Orders) Central Rules, 1946.
- 1.5 The Contractors shall get the above said rules known as standing orders certified under the Industrial Employment (Standing Orders) Act, 1946, or should already have got certified by the certifying officer under this Act, if the number of workmen employed by them is 100 or more. The appropriate Government for the purpose of this act is the

- government of the State in which the project work is being carried out by the concerned contractor.
- 1.6 The Contractor shall give 'Notice of discontinuance or re-starting of a shift working' in the prescribed format given in the rules framed by the concerned State Government under the Act.
- 1.7 The Contractor shall give a notice to the workers in respect of any change in the conditions of employment and he cannot effect such change within 21 days of giving such notice as required under section-9 of Industrial Disputes Act, 1947.
- 1.8 Any cessation of employment like lay-off or retrenchment shall be resorted to complying with the conditions stipulated in Industrial Disputes Act, 1947.
- 1.9 No contractor or any worker or any trade union whether registered under the Trade Unions Act, 1926 or not, shall commit any unfair labour practice given in the Fifth Schedule of Industrial Disputes Act, 1947.
- 1.10 Any dispute arising out of terms and conditions of employment or non-employment, between the Contractor and his workers, two or more contractors or among the workers shall be resolved in accordance with the provisions contained in the Industrial Disputes Act, 1947.
- 2.0The Contractor shall ensure that no discrimination is made against women at the time of recruitment or in any condition of service subsequent to recruitment such as promotion, training or transfer.
- 3.0The Contractor shall not allow or require a woman to work between 6 pm and 7 am.
- 4.0The Contractor shall comply with the provisions contained in The Child Labour (Prohibition and Regulation) Act, 1986 and shall not employ any child. The appropriate government is State Government for this purpose.
- 5.0The Contractor will protect the right of the workers to form trade unions in accordance with the provisions contained in The Trade Unions Act, 1926.

## **CHAPTER-III Salary and Wages**

### **1.0 Payment of salary and Wages**

The Contractor shall make payment of salary and wages to his employees on or before seventh day of the following month. However, payment to workers engaged on daily basis, casual workers and piece-rated workers may be released on or before seventh day after the wage period.

### **1.1 Permissible Deductions**

**The deductions on account of the following from the wages are the permissible as per the Payment of Wages Act, 1936:**

- a) Absence of duty and fines if any;
- b) House accommodation if provided;
- c) Recovery of advance and loans given;
- d) Income tax, Provident fund, ESI contribution and LIC premium,
- e) Amenities provided.

Deduction by order of Court etc. is permitted. Maximum deduction can be 50%. However, maximum deduction up to 75% is permissible if deduction is partly made for payment to cooperative society.

### **1.2 Documentation**

**The Contractor shall maintain following registers/documents:**

- a) Salary registers.
- b) Attendance registers.
- c) Advance register.
- d) Deduction registers.
- e) Over time register.
- f) Fine Registers.
- g) Wage Slips.

### **2.0 Minimum Wages**

The Contractor shall pay fair wages to his employees keeping in view the best practices and industry standards. It must be ensured that workers in various categories are paid not less than the minimum wages fixed and notified by the Central / State Government as applicable.

### **3.0 Documentation**

#### **3.1.1 The Contractor shall maintain documents and records as per the rules including the following:**

- a) muster roll in Form VII;
- b) Registers in respect of Advance, Deduction, Over Time and Fines;
- c) Wage slips;

- d) Display of Form X Abstract;
  - e) Display of Minimum Wages.
- 3.1.2 The Contractor shall ensure submission of Annual Return, to the Regional Labour Commissioner (Central) before 31 of January.

#### **4.0 Bonus**

The Contractor shall pay bonus in an accounting year to his employees drawing salary not exceeding rupees ten thousand per month, in accordance with the provision of the Payment of Bonus Act, 1965.

- 4.1 The Contractor shall be bound to pay a minimum bonus of 8.33 per cent of the salary or wages earned by an employee during the accounting year and the maximum bonus would be 20 per cent. The amount of bonus payable to the employees shall be calculated in a manner as given in the Payment of Bonus Act, 1965, as amended from time to time.
- 4.2 If the salary or wages of an employee exceeds rupees three thousand five hundred, bonus shall be calculated as if his salary or wages were rupees three thousand five hundred per month.
- 4.3 Every employee shall be entitled to be paid bonus in an accounting year, in accordance with the provisions of this Act, provided he has worked in the establishment for not less than thirty working days in that year.
- 4.4 The Contractor shall ensure submission/maintenance of records as required under the Act and rules:
  - a) Preparation & Maintenance of Form A, Form B and Form C (Registers);
  - b) Submission of Annual Return in Form D before 30th November.
- 4.5 The appropriate government for the purpose of this Act is the Central Government.

#### **4.0 Equal Pay for Equal Work**

- 4.1 The Contractor shall comply with the provisions contained under the Equal Remuneration Act, 1976 and ensure payment of equal remuneration to men and women workers performing the same or similar work.



## **CHAPTER-IV SOCIAL SECURITY**

### **1.0 Provident Fund**

- i) The Contractor shall cover his employees under the Employees Provident Fund and Miscellaneous Provisions Act, 1952 via independent code numbers allotted to him by the Central Provident Fund Organisation, prior to his participation in the bidding process.
- ii) The Contractor shall ensure compliance to the above Act including the following:
  - a) Calculation of provident fund liability & preparation of monthly provident fund Statement;
  - b) Preparation of provident fund challan in quadruplicate;
  - c) Submission of PF Challan before 15th of every month along with the cheque to the authorized bank and obtaining the acknowledgement;
  - d) Obtaining the Triplicate and Quadruplicate Bank clearance Challan;
  - e) Obtaining Form.No-2 from new entrants joined during the month;
  - f) Maintenance of Provident Fund Register on monthly basis;
  - g) Preparation & Submission of Form 12-A on monthly basis;
  - h) Submission of PF Nomination forms for every new employee on monthly basis;
  - i) Preparation & Submission of Form-12A, Form-5 & Form-10 and Form.No-2 along with the triplicate copy of the Challan to PF Department before 15th/25th of the Month;
  - j) Maintaining Form -11;
  - k) Processing of Form 13 and submission to Central Provident Fund Organisation;
  - l) Processing of Form 20,10D and Form 5(IF) in respect of death claims.
  - m) Preparation & submission of Form-9;
  - n) Submission of withdrawal forms and doing follow-up till it gets settled;
  - o) Correspondence with provident fund authorities whenever required;
  - p) Attend periodical inspections by provident fund officers and comply their observations;
  - q) Preparation & Submission of Annual Return in Form No 3A & 6A every year;
  - r) Maintenance of Inspection book;
  - s) Processing of FomNo.31, if required;
  - t) Follow-up and obtaining Form.No-23 (annual account slips) from the Central Provident Fund Organisation.

### **2.0 Employees State Insurance**

- i) The Contractor shall cover his employees under the Employees State Insurance Act, 1948 via independent code numbers allotted to him by the Employees State Insurance Corporation, prior to his participation in the bidding process.
- ii) The Act applies to factories. The Act will apply to any process of construction which comes within the definition of factory as contained under The Factories Act, 1948 as amended from time to time. For example, the workshops and production centre are covered under The Factories Act, 1948.
- iii) The Act does not apply to construction workers. However the following employees are covered:
  - a) Those who are employed in the administrative offices if their number is 20 or more;
  - b) Those who work in the factories owned by the Contractor and subcontractors, undertaking turnkey execution of works;
  - c) Those who are earlier covered under the Act and are deployed/deputed in the project;

- d) Staff deployed in canteen.
- iv) It is advised that the Contractor should explore the possibility of covering all the employees under this Act if the ESI hospital facility is available in the vicinity of work sites. This will ensure better health facility for the employees besides facilitating smooth administration of the benefit. Alternatively, the Contractor can provide better benefits than those available under the Act to the covered employees and seek exemption from the operation of the Act.
- v) In respect of the employees covered under the Act, the Contractor shall ensure documentation as per the Act including the following:
  - a) Calculation of ESI liability & Preparation of ESI Monthly Statement;
  - b) Preparation of ESI Challan in Quadruplicate;
  - c) Submission of ESI Challans before 21st of every month along with the payment authorisation to the authorized bank and obtaining the acknowledgement;
  - d) Obtaining the Triplicate and Quadruplicate bank clearance Challan;
  - e) Maintenance of Form-7 (registers);
  - f) Obtaining Form.No-1 from new entrants and submission along with Form.No-3 to the ESI Local Office within 10days from the date of the appointment;
  - g) Collecting ESI Temporary and Permanent cards from ESI Branch office;
  - h) Submission of Accident reports in Form-16 to ESI Dispensaries/ESI Branch Office;
  - i) Maintenance of Accident Registers;
  - j) Maintenance of Inspection Book;
  - k) Processing of claims forms for Funeral Expenses;
  - l) Maintenance of ESI Register on monthly basis;
  - m) Correspondence with ESI Authorities whenever required;
  - n) Attend periodical Inspections by ESI Authorities and comply with statutory requirements;
  - o) Preparation and Submission of ESI Half yearly return before 12th May and 11th November of each year;
  - p) Processing of Forms prescribed under the Act;
  - q) Submission of annual return before 31st of January.

### **3.0 Gratuity**

- i) The Contractor shall ensure payment of gratuity to the eligible employees in accordance with the provisions contained in The Gratuity Act, 1972.
- ii) Gratuity is payable to a person on (a) resignation (b) termination on account of death or disablement due to accident or disease (c) retirement (d) death. Normally, gratuity is payable only after an employee completes five years of continuous service. In case of death and disablement, the condition of minimum 5 years' service is not applicable.
- iii) Gratuity is payable @ 15 days salary/wages for every year of completed service. In the last year of service, if the employee has completed more than 6 months, it will be treated as full year for purpose of gratuity.
- iv) In case of employees paid on monthly salary/wages basis, per day wages should be calculated by dividing monthly salary by 26 days to arrive at daily wages e.g. if last drawn salary of a person (basic plus DA) is Rs. 2,600 per month, his salary per day will be Rs.

100 (2,600 divided by 26). Thus, the employee is entitled to get Rs. 1,500 [15 days multiplied by Rs. 100 daily salary] for every year of completed service. If he has completed 30 years of service, he is entitled to get gratuity of Rs. 45,000 (Rs. 1,500 multiplied by 30). Maximum gratuity payable under the Act is Rs. 10 lakhs.

- v) The Contractor shall obtain an insurance from the Life Insurance Corporation of India established under the Life Insurance Corporation of India Act, 1956 (31 of 1956) or any other prescribed insurer for his liability for payment towards the gratuity under this Act.
- vi) The Contractor shall ensure documentation including the following:
  - a) Submission of Form No.1 to Deputy Labour Commissioner (Central);
  - b) Maintenance of Form F Nomination;
  - c) Arranging for Formation of Trust;
  - d) Arranging for obtaining the Scheme from Insurance Company;
  - e) Processing Gratuity Application Form;
  - f) Display of Abstract on Notice Board.
- vii) The appropriate government is the Central Government for the purpose of this act.

#### **4.0 Maternity Benefit**

- i) The Contractor shall not employ a woman to work during the six weeks immediately following the day of her delivery, miscarriage or medical termination of pregnancy.
- ii) The Contractor shall not require a pregnant woman, to do any work which is of an arduous nature or which involves long hours of standing, or which in any way is likely to interfere with her pregnancy or the normal development of the foetus, or is likely to cause her miscarriage or otherwise to adversely affect her health before the date of her expected delivery, even on a request being made by her, during:
  - a. the period of one month immediately preceding the period of six weeks
  - b. any period during the said period of six weeks for which the pregnant woman does not avail of leave of absence to which she is entitled.
- iii) The Contractor shall allow maternity benefits including leave to which a pregnant woman employee is entitled to under the provisions contained in The Maternity Benefit Act, 1961, as amended from time to time.
- iv) The Contractor shall ensure:

- a. Submission of Form-U before 31st January.
- b. Maintenance of Register pertaining to Maternity Benefit Act.
- v) The appropriate government in respect of this Act is the concerned state government.

#### **5.0 Employees Compensation**

- a) The Contractor shall be liable to pay compensation if personal injury is caused to an employee by accident including certain occupational diseases arising out of and in the course of his employment resulting in death or disablement in accordance with the provisions of the Employees Compensation Act, 1923.
- b) The Contractor shall arrange for:
  - i. Obtaining License from any Insurance Office.
  - ii. Submission of New Joiners list to the Insurance Office under the act.
  - iii. Renewal of WCA Policies as the date ends.
  - iv. Submission of Form-EE to Labour Department of the Area where the Establishment comes under.
  - v. Depositing the amount to the Labour Department in case of Accident or Death.
  - vi. Submission of Accident report to relevant authorities specified in applicable laws including:
    - a. Regional Labour Commissioner (Central) having jurisdiction in the area;
    - b. The Building and Other Construction Workers Welfare Board with which the worker involved in accident is registered; The Director General appointed under the BOCW Act, 1996;
    - c. Inspector of Factories if the workplace is a factory;
    - d. The next of kin or other relative of the worker involved in the accident;
    - e. Commissioner appointed under the Employees Compensation Act, 1923 if the rules framed by the state government under the Act, 1923.
- c) The appropriate government for the purpose of this Act is the concerned State Government.

#### **CHAPTER-V**

### Occupational Safety, Health and Welfare

- 1.0 The Contractor shall at all times take reasonable precautions to maintain the safety and health of his personnel. The Contractor shall provide basic and improved welfare measures to facilitate smooth and healthy working conditions.
- 2.0 The Contractor shall comply with the provisions contained in The Building and Other Construction Workers (Regulation of Employment of Service) Act, 1996 and contractual conditions with regard to safety, health and welfare.
- 3.0 The Contractor shall maintain appropriate records and file returns etc., in compliance with the statutory requirements provided under The Building and Other Construction Workers (Regulation of Employment of Service) Central Rules, 1998 which shall include the following:

Rule	Item	Form
23(1)	Application for registration of establishments employing building workers	I
26(3) and 239(1)	Notice of commencement/completion of building or other construction work	IV
56 and 74(b), Schedule-I	Certificate of initial and periodical test and examination of Winches, Derricks and their Accessory Gear	V
56 and 74(b)	Certificate of initial and periodical test and examination of Cranes or Hoists and their Accessory Gear	VI
70 and 74(b)	Certificate of initial and periodical test and examination of Loose Gears	VII
62 and 74(b)	Certificate of test and examination of Wire-rope before being taken into use	VIII
72 and 74(b)	Certificate of Annealing of loose Gears	IX
69 and 73	Certificate of annual thorough examination of Loose Gears exempted from annealing	X
223 (c )	Certificate of medical examination	XI
223(d)	Health register	XII
230(a)	Notice of poisoning or occupational notifiable diseases	XIII
210(7)	Report of accident and dangerous occurrences	XIV
240	Register of building workers	XV
241 (1) (a)	Muster-Roll	XVI
241 (1) (a)	Register of wages	XVII
241 (1) (a)	Form of Register of wages – cum - Muster-Roll	XVIII
241 (1) (b)	Register of deductions for damage or loss	XIX
241 (1) (b)	Register of fines	XX
241 (1) (b)	Register of advances	XXI

<b>Rule</b>	<b>Item</b>	<b>Form</b>
241 (1) ©	Register of overtime	XXII
241 (2) (a)	Wage book	XXIII
241 (2) (b)	Service certificate	XXIV
242	Annual return to be sent to registering officer	XXV
74 (b)	Register of periodical test – Examination of lifting appliances and gears etc.	XXVI

## CHAPTER-VI Compliance with Other Labour Laws

- 1.0 The Contractor shall comply with the provisions of other applicable labour laws besides the Acts mentioned in foregoing chapters.
- 2.0 The Contractor shall comply with the provisions contained in The Contract Labour (Regulation and Abolition) Act and take steps to:
  - a) Obtain a License from Assistant Commissioner of Labour (Central).
  - b) Submit an Annual Return in Form XXV before 15th of February.
  - c) Maintenance of sub-contractor registers in Form XIII.
  - d) Maintain records/registers as per the Act.
- 2.1 The appropriate government is the central government in this case.
- 3.0 The Contractor shall comply with the provisions of The Factories Act, 1948, wherever applicable and take steps to:
  - a) Renew his Factory license before 30th October every year or as the case may be.
  - b) Display Abstracts.
  - c) Submit Form-21 before 15th July (Half Yearly Returns).
  - d) Submit Form-20 before 15th February (Annual Returns).
  - e) Maintain Inspection, Accident and Adult & Census Register.
  - f) Submit Accident report to Inspector of Factories.
  - g) Intimate Annual Holidays to Inspector of Factories before 31stDecember.
- 3.1 The appropriate government for the purpose of this Act is the concerned State Government.
- 4.0 The Contractor shall comply with the State Act and notifications being made thereunder that stipulate the National and festival Holidays and observe holidays as notified by the concerned State Government including Republic Day, Independence Day and Gandhi Jayanti. The appropriate government is the State Government for this purpose.
- 5.0 The Contractor shall comply with the provisions contained in The Inter-State Migrant Workmen (Regulation of Employment and Conditions of Service).
- 5.1 The Contractor shall not directly or through subcontractors or agents recruit any person in a state for the purpose of employing him in the project located in another state except under and in accordance with the license issued under this Act.

- 5.2 The Contractor shall abide by the duties and obligations as enumerated under this Act and furnish all such information including filing of returns or any other document with the statutory authorities, as may be required from time to time.
- 5.3 The appropriate government for the purpose of this Act is the Central Government.
- 6.0 In cases of construction of tunnels, the Contractor shall comply with the provisions of The Mines Act, 1952.



## CHAPTER-VII Implementation and Monitoring

### 1.0 Implementation

- 1.1 The provisions contained in this policy, various applicable labour laws and Bid Documents regarding staff and labour shall be complied in letter and spirit. Periodic review shall be undertaken through self-regulatory and audit mechanism.
- 1.2 The Contractor shall appoint the following key officials who will look after the implementation of this policy besides ensuring compliance of statutory and contractual obligations regarding occupational safety, health and welfare:

OFFICIAL	QUALIFICATION
Safety Officer	i) Degree in Engineering or Technology or Architecture with practical experience of at least 2 years; or Diploma Engineering or Technology with practical experience of at least 5 years. ii) Recognized degree or diploma in industrial safety with at least one paper in construction safety (as an elective subject) iii) Adequate knowledge of the language spoken by majority of workers of the work site.
Construction Medical Officer	MBBS degree from a medical institute recognized by the Medical Council of India and; Diploma in industrial health or equivalent post-graduate certificate of training in industrial health; A medical officer having more than 3 years of experience in policy, execution, advice and safety and health of workers employed in mines, ports and docks, factories, building and other construction work, may be considered without the qualification mentioned at (b) above.
Welfare Officer/ Personnel Officer	(i) Degree of a recognized University or equivalent. (ii) Post-graduate Degree/Diploma in Social Work or Labour Welfare or Industrial Relations or Personnel Management or in any other allied subject of a recognized University or equivalent. (iii) 7 years' experience in a responsible capacity of Labour Welfare Work, Industrial Relations or Personnel Management

- 1.3 The Contractor shall appoint an adequate number of key officials and support staff trained in respective disciplines to work with. Employer's decision in regard to the staff strength shall be final and binding on the Contractor.
- 1.4 The Contractor shall arrange to keep all applicable updated bare Acts and rules framed there-under by respective appropriate government as mentioned in this policy, in its

library. The required Forms for documentation and filing of returns etc are available in these rules.

## **2.0 Monitoring**

2.1 A Joint coordination committee (JCC) shall be constituted by the Employer in respect of the contracts awarded by the DFCCIL where this policy is required to be implemented.

2.1.1 The JCC shall monitor the implementation of this policy.

2.1.2 The JCC shall consist of the representatives of:

- a) Employer;
- b) Project Management Unit (PMU);
- c) Contractors;
- d) Any other member as may be decided by the Employer.

The chairman of the JCC shall be nominated by the Employer.

2.1.3 The JCC shall meet once in every three months, review compliance and send report to the Employer.

2.2 A project coordination committee (PCC) shall be constituted by the JCC in respect of each contract awarded by the DFCCIL where this policy is required to be implemented.

The PCC shall consist of the following members:

- a) The Engineer;
- b) The Contractor;
- c) Representative of Workers;
- d) Any other member to be nominated by the Engineer.

2.2.1 The PCC shall monitor every month the implementation of this policy at the project level and send a monthly report to the JCC.

## **ATTACHMENT 8**

### **WORK PLACE POLICY**

#### **DFCCIL's WORKPLACE POLICY ON HIV/AIDS PREVENTION & CONTROL FOR WORKERS ENGAGED BY CONTRACTORS**

##### **1.0 Background and Rationale**

DFCCIL recognizes that the continuing spread of HIV/AIDS constitutes a serious obstacle to the process of development and realizes that there is a need to have coordinated and sustained response to the HIV/AIDS epidemic.

DFCCIL recognizes that access to medication in the context of pandemics such as HIV/AIDS is one of the fundamental elements necessary to achieve progressively the full realisation of the right of everyone to the enjoyment of the highest attainable standard of physical and mental health.

DFCCIL recognizes that care, support and treatment can contribute to effective prevention through increased acceptance of voluntary and confidential counseling and testing and by keeping people living with HIV/AIDS and vulnerable groPSS in close contact with health-care systems and facilitating their access to information, counseling and preventative supplies.

DFCCIL recognizes that effective prevention, care and treatment strategies will require behavioral changes and increased availability of and non-discriminatory access to, inter alia, vaccines, condoms, microbicides, sterile injecting equipment, drugs including anti-retroviral therapy, diagnostics and related technologies as well as increased research and development;

##### **2.0 General**

- 2.1 The transmission of the Human Immuno-deficiency Virus (HIV) is through:
  - Unprotected sexual contact with an infected person;
  - Transfusion of infected blood or blood products;
  - Sharing of infected needles or syringes and
  - From infected mother-to-child during pregnancy, childbirth or breast feeding.
- 2.2 There is no scientific or epidemiological evidence to suggest that HIV can be transmitted through ordinary workplace contact (talking to or touching the person, using the same office equipment, tools, utensils or bathroom). Transmission is therefore not likely in the regular workplace setting.
- 2.3 People with HIV may remain healthy and fit to work for several years despite their infection.
- 2.4 With the availability of Anti Retroviral Treatment, the life of people living with HIV can be prolonged substantially and they can lead a normal productive life.

##### **3.0 Aim**

The policy aims to:

- Prevent transmission of HIV infection amongst workers engaged by the Contractor including those of his subcontractors and consultants and their families;
- Provide access to care, support and treatment to those who are infected;

- Protect workers from stigma and discrimination related to HIV/AIDS by assuring them equity and dignity at the workplace;

#### **4.0 Scope**

This policy applies to all contractors, subcontractors, consultants and their employees (including applicants applying them for work) in the work sites, office locations, accommodation camps, all other workplaces and contracts of employment and all aspects of work, formal and informal and the self-employed worker engaged with the Contractor for providing goods or services at any work location and their spouse and children or other family members, residing with the worker.

#### **5.0 Guiding Principles**

5.1 The policy adopts the key principles of the International Labour Organisation (ILO) 'Code of Practice on HIV/AIDS and the World of Work' that are in line with the Government of India's 'National HIV/AIDS Policy' and approach of Japan International Cooperation Agency (JICA).

5.2 Based on above, the Contractor shall:

- a) Provide a safe and healthy work environment for employees;
- b) Educate its employees and their family members on prevention, care and treatment of HIV/AIDS;
- c) Provide counselling service;
- d) Educate its employees on safe blood donation and transfusion;
- e) Maintain confidentiality with regard to the identity and medical information of an infected employee. Only the immediate senior would be kept advised to prevent any medical eventuality;
- f) Allow an HIV positive employee to continue to work in his or her job unless medical conditions interfere with the job requirement. On health grounds, the employee may be shifted to another job for which he is medically fit;
- g) Ensure continued employment and benefits to people living with HIV (PLHIV);
- h) Ensure that the co-employees do not shun their HIV positive peer or refuse to work alongside them;
- i) Not discriminate against any employee infected by HIV/AIDS with regard to promotions, training and any other privileges, applicable to all employees of his organisation;
- j) Not ask any person who is being offered a job to undergo HIV/AIDS prevalence test, without an informed consent and pre-test counselling of the candidate, as a

part of general medical examination before the issue of the appointment letter, or otherwise;

- k) Educate its employees and encourage them to participate in voluntary counseling and testing of HIV/AIDS. However, HIV/AIDS tests shall not be a part of any annual or regular health check PSS, without the employee's informed consent and pre test counseling.
- l) Ensure that proper treatment is available to employees infected with HIV/AIDS and prescribe a reasonable limit on expenditure in meeting the cost of anti-retroviral (ARV) drugs. All other costs related to treatment of HIV/AIDS (non-ARV) shall be borne by the Contractor.
- m) Empanel appropriate hospital(s) for treatment of HIV/AIDS of an infected employee and release payment directly to such hospital.

## **6.0 Action Plan**

- 6.1 The Contractor shall engage a professional agency (PA), with approval of the Engineer, to facilitate implementation of the guidelines laid down in this policy by the Contractor.
- 6.2 The Contractor shall undertake measures to reduce the risk of the transfer of HIV virus between and among the Contractor's employees including those engaged by his subcontractors and the local community, to promote early diagnosis and to assist the affected individuals.
- 6.3 The Contractor shall conduct Information, Education and Communication (IEC) campaigns via, the appointed professional agency, once in every month, addressed to all employees including the employees of subcontractors and consultants, all truck drivers, helpers, crew making material deliveries at the site and the local communities. The IEC campaign shall focus on risks, dangers, impact and avoidance behavior in respect of:
  - a) Sexually transmitted diseases (STD);
  - b) Sexually transmitted infections (STI);
  - c) HIV/AIDS
- 6.3.1 The IEC campaign shall include distribution of informative leaflets, screening of educative films, display of posters and banners, small group lectures, street plays etc.
- 6.4 The Contractor shall identify peer educators (one for every one hundred workers) from among his employees and refer them for professional training to the appointed professional agency.
  - 6.4.1 The peer educators on completion of the training shall serve as the focal point for any information, education and awareness campaigns among the workers throughout the contract period.
  - 6.4.2 The peer educators shall be paid a monthly honorarium as fixed by the Contractor for rendering these services in addition to their regular duties.

- 6.4.3 The total number of peer educators (1 for 100 workers) shall always be maintained by the Contractor.
- 6.4.4 If a peer educator leaves the Contractor's employment, then the Contractor at his own expense shall train the new replacement peer educator via the Engineer/Employers' appointed agency for the purpose.
- 6.5 The Contractor shall establish on-site health clinics to provide free of charge counseling and information on STI/HIV/AIDS and first-aid services.
- 6.5.1 The Contractor shall provide facility for STI and HIV/AIDS screening, diagnosis and referral to a dedicated national STI and HIV/AIDS programme in such clinics.
- 6.5.2 The Contractor shall arrange for health checks including HIV/AIDS screening before work begins and annually thereafter.
- 6.6 The Contractor shall arrange for free supply of condoms at accommodation camps.
- 6.7 The Contractor shall submit, as a part of the Project SHE Plan, a comprehensive action plan listing the activities to be undertaken regarding prevention of STI and HIV/AIDS, within 42 (forty two) days of award of the contract, for approval of the Engineer.
- 6.8 The action plan shall contain various activities to be undertaken by the Contractor during the period of contract as mentioned in this policy and specified in the contract.

## **7.0 Implementing Organisation**

- 7.1 A Joint Coordination Committee (JCC) shall be constituted by the Employer in respect of the contracts awarded by the DFCCIL where this policy is required to be implemented.
- 7.1.1 The JCC shall monitor the implementation of the Employer's workplace policy on HIV/AIDS prevention and control for employees engaged by the Contractors.
- 7.1.2 The JCC shall consist of the representatives of:
- a) Employer;
  - b) Project Management Unit (PMU);
  - c) Professional Agency appointed by the Employer;
  - d) Contractors;
  - e) State Aids Control Society (SACS);
  - f) State Health Department;
  - g) A Subject matter specialist;
  - h) Any other member as may be decided by the Employer.

The chairman of the JCC shall be nominated by the Employer.

- 7.2 A project coordination committee (PCC) shall be constituted by the JCC in respect of each contract awarded by the DFCCIL where this policy is required to be implemented. The PCC shall consist of

the following members:

- a) the Engineer
- b) the Contractor
- c) Representative of the professional agency appointed by the Employer;
- d) Representative of SACS/Local Health Department of the state;
- e) Representative of Workers;

7.2.1 The PCC shall monitor the implementation of the Employer's workplace policy on HIV/AIDS prevention and control for employees engaged by the Contractors at the project level.

### 8.0 Role of Key Stakeholders

8.1 The following shall be the role of the key stake holders with regard to implementation of this policy:

Key Stakeholder	Role
JCC	<p>The JCC shall:</p> <ul style="list-style-type: none"> <li>a) Examine the action plan submitted by the Contractor under this policy or the contract and recommend the same for approval of Employer;</li> <li>b) Monitor and evaluate the progress of activities, budget utilisation etc. under this policy or the contract;</li> <li>c) Discuss and advise on major issues that arise during implementation;</li> <li>d) Conduct periodic review and take remedial steps, if required;</li> <li>e) Give periodic progress reports to the Employer.</li> </ul> <p>The JCC shall meet once in six months or whenever the necessity arises.</p>
PCC	<p>The PCC shall:</p> <ul style="list-style-type: none"> <li>a) Provide guidance for implementation of the action plan approved by the Employer;</li> <li>b) Monitor and review the activities being undertaken including resource utilisation;</li> <li>c) Advise on problems being faced by the Contractor during implementation;</li> <li>d) Give periodic progress report to the Engineer and JCC.</li> </ul> <p>The PCC shall meet once in two months or whenever necessity arises.</p>
PMU	<p>The PMU shall designate an HIV/AIDS division to work closely with expert(s) and the professional agency.</p>
The Engineer	<p>The Engineer shall:</p> <ul style="list-style-type: none"> <li>a) Formulate, in consultation with the Employer, the project specific HIV/AIDS prevention programme;</li> <li>b) Approve the contract specific HIV/AIDS prevention programme submitted by the Contractor;</li> </ul>

	<ul style="list-style-type: none"> <li>c) Approve the Terms of Reference (TOR) submitted by the Contractor for hiring the professional agency (PA);</li> <li>d) Assist PMU in establishing and strengthening HIV/AIDS division;</li> <li>e) Coordinate with other stakeholders to modify or revise the action plan as and when required and explain the JCC for its clearance during its meetings;</li> <li>f) Supervise the programme implementation;</li> <li>g) Monitor, evaluate and report the implementation progress;</li> <li>h) Appoint an independent consultant to undertake mid-term and concurrent evaluation;</li> <li>i) Supervise Contractor's obligation under this policy or the contract for prevention and control of HIV/AIDS.</li> </ul>
<p>Contractors</p>	<p>The Contractor shall:</p> <ul style="list-style-type: none"> <li>a) Submit to the Engineer for his approval, the contract specific detailed HIV/AIDS prevention programme;</li> <li>b) Submit to the Engineer for his approval, the Terms of Reference (TOR) for hiring the professional agency (PA);</li> <li>c) Engage a professional agency with approval of the Engineer;</li> <li>d) Work with the professional agency (PA) in implementing HIV/AIDS prevention programme among his employees including the employees of his subcontractors and consultants.</li> <li>e) Establish on-site health clinics to provide the following without any charge, to his employees and their families:                         <ul style="list-style-type: none"> <li>•Information and counseling on STI/HIV/AIDS;</li> <li>•First-aid services on universal precaution for HIV/AIDS prevention;</li> <li>•Screening and diagnosis facility;</li> <li>•Referral facility to a national programme;</li> <li>•Supply of contraceptive devices to males/ females, including condoms.</li> </ul> </li> <li>f) Ensure participation of his employees and employees of his subcontractors and consultants including self-employed or piece rated employees, in the HIV/AIDS prevention programme in the course of their employment and during normal working hours;</li> <li>g) Do nothing to dissuade the employees as mentioned in (f) above from participating in HIV/AIDS prevention programme;</li> <li>h) Encourage employees to work as peer educators on HIV/AIDS prevention after being trained by the professional agency (PA);</li> <li>i) Ensure active participation of his occupational health staff in implementing the key tasks organized by the professional agency (PA);</li> <li>j) Arrange distribution of contraceptive devices including</li> </ul>



	<p>condoms in the employee accommodation camps without any charge;</p> <p>k) Arrange distribution of IEC materials among the employees and their family members prepared through the professional agency (PA);</p> <p>l) Establish linkage with SACS and/or local health authorities for their help, guidance and integration with the national programme;</p> <p>m) Facilitate monitoring activities and undertake supervision to ensure that the programme is implemented as planned;</p> <p>n) Convene monthly meeting with the professional agency (PA) for updates on progress of the programme;</p> <p>o) Report progress to the Engineer and PCC on a monthly basis</p>
--	--

The Contractor is expected to apply the above concepts to promote the same in a positive and proactive manner during the execution of its contract.

**ATTACHMENT 9**

**Reference for SHE Activities**

**Information given in this Attachment shall be used for reference (but NOT deemed to be requirements) to facilitate the Contractor to establish the SHE Plan.**

<b>DFCCIL</b>
<b>General Instruction : DFCCIL/SHE/GI/001</b>

**MINIMUM MANPOWER REQUIREMENTS OF  
 SHE ORGANIZATION BASED ON CONTRACT VALUE**

	<b>1</b>	<b>2</b>	<b>3</b>	<b>4</b>	<b>5</b>	<b>6</b>
Awarded Contract value (Rs. in Cr.)	SHE Director	CEO/CAPO	SEO/SAPO	Safety Steward	Senior SHE (Electrical) Engineer	Junior SHE (Electrical) Engineer
Up to 2	-	-	1	Refer Note 1	-	1
Up to 10	-	1	Refer Note 1		1	Refer Note 2
Up to 25	1	Refer Note 1			1	
Up to 100	1				1	
Up to 250	1				1	
More than 250	1					

	<b>7</b>	<b>8</b>	<b>9</b>	<b>10</b>	<b>11</b>
Awarded Contract value (Rs. in Cr.)	EO/CLO/SHO	Occupational Health Officer with Necessary Nursing Assistants (Refer Note 3)	Senior Traffic Engineer (Refer Note 4)	House Keeping / Site Maintenance Squads	Labour Welfare Officer
Up to 2	-	-	-		-

Up to 10	1	1 (PT)	1	Refer Note 5	1
Up to 25	1	1 (PT)	1		1
Up to 100	1	1 (FT)	1		1
Up to 250	1 with support staff	2(FT)	1		1 with support staff
More than 250	1 with support staff	2(FT)	1		1 with support staff

**Note 1:** Adequate, qualified and trained SHE Professionals with required support staff to be deployed at each worksite at each shift.

**Note 2:** Adequate, qualified and trained Electrical Engineers / supervisors to be deployed at each worksite at each shift.

**Note 3:** (PT) means Part-Time and (FT) means Full-time.

**Note 4:** Senior Traffic Engineer Post (including the staff) is applicable to contracts where the work has to be executed either below or over the ROW like viaduct, station contracts wherein erection and maintenance of barricades are paramount important.

**Note 5:** One Housekeeping / Site Management Manager supported by required supervisors and workmen

**Note 6:** The above minimum numbers are for guidance only. The actual number will depend on project specific requirements. The Contractor shall obtain Engineer's prior consent to the final numbers and organisation.

<b>DFCCIL</b>
<b>General Instruction : DFCCIL/SHE/GI/002</b>

**MINIMUM QUALIFICATION AND EXPERIENCE FOR (SHE) SAFETY,  
 ELECTRICAL, ENVIRONMENTAL, TRAFFIC ENGG.  
 AND OCCUPATIONAL HEALTH PROFESSIONALS**

<b>Sl. No</b>	<b>Designation</b>	<b>Qualification</b>	<b>Experience (in years)</b>
1	SHE Director	<p>SHE Director shall have qualified in any of the following degree/diploma:</p> <ul style="list-style-type: none"> <li>i) Govt. recognized PG Degree / PG Diploma / Degree in Environmental Engineering / Science</li> <li>ii) Post Graduate Diploma in Industrial Safety &amp; Environmental Management (PGDISEM) from National Institute of Industrial Engineering, Hyderabad</li> <li>iii) M.E. in Industrial Safety from NIT, Trichy, Tamil Nadu</li> <li>iv) M.E. in Industrial Safety from Mepco Schlenk Engineering College, Sivakasi, Tamil Nadu</li> <li>v) B.E. in Fire and Safety Engg. From Cochin University of Science and Engg. Cochin, Kerala</li> <li>vi) B.E. with advanced Safety Management Diploma from Hyderabad / Chennai / Kolkata and Kanpur.</li> <li>vii) B.E / B.Arch., with one year Full Time advanced Safety diploma from NICMAR, Hyderabad.</li> <li>viii) B.E/B.Tech with any other equivalent State and Central Govt. recognized full time Degree / Diploma in Safety.</li> <li>ix) International qualifications like CSP (Certified Safety Professional), NEBOSH, MIOSH, MSISO etc.</li> </ul>	2 {for all category except (iv) and 5yrs for category (iv)}
2	CEO/CAPO	Same as above.	Same as above

3	SEO/SAPO (Refer Note 1)	As stated in Sl. No:1 above and in addition the following categories: i) B.Sc.(Physics/Chemistry/Maths) with one year Full Time advanced Safety diploma from NICMAR, Hyderabad ii) B.Sc. / Diploma in Engg. with advanced Safety Management Diploma from Hyderabad / Chennai / Kolkata and Kanpur. iii) B.Sc. (Physics/Chemistry/Maths) with One year Full Time diploma in Safety Engineering offered by West Bengal State Technical Education Departments and similar courses by other states. iv) Any Graduate or diploma holder with 7 years of work experience in full fledged SHE department of any Public Sector / Leading Private Sector / MNC / with prior approval of Engineer/ Employer on a case to case basis	2 {for category (i), (ii) and (iii) only}
4	EO/SHO	i) Degree in Environmental Engineering /Science / Diploma in Engineering with Govt. recognized safety diplomas from Correspondence course of NICMAR, Other State Technical Education Boards etc. ii) Any Graduate or diploma holder with 5 years of work experience in full fledged SHE department of any Public Sector / Leading Private Sector / MNC / with prior approval of Engineer/ Employer on a case to case basis	2 (for category (i) only)
5	CLO	Govt. recognized PG Degree / PG Diploma / Degree in Sociology/ Socialscience	2
6	Senior SHE (Electrical) Engineer	Degree in Electrical Engineering + Govt. recognized Electrical Licence holder	2
7	Junior SHE (Electrical) Engineer	Diploma in Electrical Engineering + Govt. recognized Electrical Licence holder	1
10	Occupational Health Officer	MBBS with Govt. recognized degree/diploma in Industrial/ occupational health	1
12	Senior TrafficEngineer	Govt. recognized PG Degree / Degree / Diploma in Traffic/Transportation Engineering or Planning	1

13	House Keeping / Site Manager	Any Diploma in Engineering	1
14	Labour Welfare Officer	Any Degree with Govt. Recognized Degree / Diploma / P G Diploma in Labour Welfare related fields like Law, Personnel / Industrial Relations etc.	2

The qualifications and experience in respect of the following positions shall be proposed by the Contractor and seek consent of the Engineer before their mobilization at Site

- (a) Sr. Environment Officer
- (b) Community Liason Officer

**Note 1:** In some extraordinary cases where the candidate had earlier worked successfully in DFCC Projects, they can be considered for the following posts:

- i)Senior Accident Prevention Officer
- ii)Junior Accident Prevention Officer
- iii)Safety and Health Officer

depending upon the qualification and no. of years of experience on a case to case basis even if they do not possess the prescribed qualification as listed above.

**Note 2:** In all other cases other than listed under note 1 (i), (ii) and (iii) irrespective their earlier experience with DFCC projects, the candidates shall qualify as specified above.

<b>DFCCIL</b>
<b>General Instruction : DFCCIL/SHE/GI/003</b>

**MINIMUM REQUIREMENTS OF SHE MONITORING AND AUDIO-VISUAL EQUIPMENT**

- For the purpose of minimum requirements of audio-visual and other equipment the contracts are categorized into the following groPSS:

Contract Value (Initial awarded value of contract)	Group
Upto Rs. 25 Cr	A
Upto Rs. 100 Cr	B
Upto Rs. 250 Cr	C
More than Rs. 250 Cr	D

- Every contractor falling into the above groPSS shall provide the following minimum required audio visual aids for conducting weekly review, monthly safety committee and other post review meeting of all fatal and major incidences effectively. These audio-visual equipment are a must for conducting periodical in-house safety presentations in the training programmes.
- In addition to the above, portable hand held digital sound level meter (SLM) and portable hand held digital lux meter are also to be provided.

Sl. No	SHE Monitoring and Audio-Visual Equipment details	SHE Monitoring and Audio-Visual equipment required for			
		Group A Contract	Group B Contract	Group C Contract	Group D Contract
1.	Portable hand held Digital Sound Level Meter (SLM)	1	1	1	1
2.	Portable hand held Digital Lux Meter	1	1	1	1
3.	Laptop computer with standard configuration including multimedia facilities	1	1	1	1
4.	Colour printer	1	1	1	1
5.	Computer projector with screen	-	1	1	1
6.	Overhead projector	1			

7.	35mm Camera (For taking accident investigation photos in which case the images can not be easily altered)	1	1	1	1
8.	Digital camera with flash of minimum 4 mega pixel and video facility	1	1	1	2
9.	Digital still camera with flash of minimum 4 mega pixel	1	2	4	6
10.	Portable loudspeaker (for tool-box talk and emergency purpose)	1	1	2	6
11.	Communication facility like mobile phone, walky-talky etc	For all supervisors and managers/engineers working in Safety, Health & Environment			
12.	Accident investigation Kit containing the following:	1	1	1	2
a)	Chalk piece for marking				
b)	Measuring tape for measuring <ul style="list-style-type: none"> <li>• Flexible tape – 2m length</li> <li>• Metal Foot long scale and</li> <li>• Metal tape – 30m</li> </ul>				
c)	Equipment tags				
d)	Multipurpose Flash light				
e)	Barrier tape of 20m length				
f)	Accident investigation Forms and checklists				
g)	Enough Paper for witness recording and other noting				
h)	Emergency Phone Numbers list				



**DFCCIL**

**General Instruction : DFCCIL/SHE/GI/004**

**Topics for First Day at Work SHE Orientation Training of Workmen**

**1. Hazard Identification Procedure**

Hazards on site:

- Falls
- Earthing work
- Electricity
- Machinery
- Handling materials
- Transport
- Site housekeeping
- Fire
- Safety of nearby located structures
- Works close to railway tracks or roads

**2. Personal Protective Equipment**

- What is available?
- How to obtain it?
- Correct use and care.

**3. Health**

- Site welfare facilities
- Potential health hazards
- First Aid/CPR

**4. Duties of the Contractor**

- Brief outline of the responsibilities of the Contractor by law
- Details of Contractor's accident prevention policy
- DFCC's SHE manual (if any)
- Building and other Constructions Welfare Law

**5. Employee's Duties**

- Brief outline of responsibilities of employee under law
- Explanation of how new employees fit into the Contractor's plan for accident prevention (induction and orientation).

**DFCCIL**

**General Instruction : DFCCIL/SHE/GI/005**

**ID Card Format  
 (85 mm x 55mm)**

**Front side of ID Card:**

**Backside of ID Card:**

															<b>Types of training</b>									
Contractor's Repr	Sr. Construction Managers	Quality Manager	Planning engineer	Construction Managers	Construction Supervisors	Construction Foreman	Machinery Operators	Material Handlers	Station Building Workers	Steel workers	Mechanical workers	Other Civil workers	Electrical workers	Radiographers	Transportation Drivers	Security Officers	Clerical Staff	Medical Officer	Sr. SHE Managers	Jr. SHE Managers	SHE Supervisors			
•	•	•	•	•	•	•	•	•	•	•	•	•	•	•	•	•	•	•	•	•	•	•	•	SHE Orientation
																			•	•	•	•	•	SHE Leadership
•	•	•	•	•	•	•	•	•	•	•	•	•	•	•	•	•	•	•	•	•	•	•	•	SHE Plan
•	•	•	•	•	•	•	•	•	•	•	•	•	•	•	•	•	•	•	•	•	•	•	•	SHE Improvement Plan
•	•	•	•	•	•	•	•	•	•	•	•	•	•	•	•	•	•	•	•	•	•	•	•	Management of Change
•	•	•	•	•	•	•	•	•	•	•	•	•	•	•	•	•	•	•	•	•	•	•	•	SHE Audit & Inspection
•	•	•	•	•	•	•	•	•	•	•	•	•	•	•	•	•	•	•	•	•	•	•	•	SHE Emergency Response & Preparedness

**DFCCIL**

**General Instruction : DFCCIL/SHE/GI/006 [SHE Training Matrix]**

**DFCCIL**

**General Instruction : DFCCIL/SHE/GI/007**

**SHE Training Details for Managers and Supervisors**

<b>1. The Law and Safety</b>	<b>2. Policy and Administration</b>
Statutory requirement Appropriate regulations Duties of employer and employee	Effect of incentive on accident prevention  SHE Policy Industrial relations Safety Officer: duties, aims, objectives
<b>3. Safety and the Supervisor</b>	<b>4. Principles of Accident Prevention</b>
Safety and efficient production  Accidents affect morale and public relations	Attitudes of management, supervision and operations Methods of achieving safe operations Accident and injury causes
<b>5. Site Inspection</b>	<b>6. Human Behavior</b>
The role of management Hazard Identification Procedure Records results Follow-up procedures Feedback	Motivating agencies Individual behavior Environmental effects Techniques of persuasion
<b>7. Site housekeeping</b>	<b>8. Health</b>
Site organization Relationship of site housekeeping to accident occurrence Site access Equipment storage Material stacking Materials handling	Medical examination Hazard to health on site  Sanitation and welfare Protective clothing First Aid/CPR
<b>9. Personal Protective Equipment</b>	<b>10. Electricity</b>
Eye, face, hands, feet and legs Respiratory protective equipment Protection against ionizing radiation	Appreciation of electrical hazards Power tools Arc welding Low voltage system Lighting and power system on sites ELCB, RRCB, Grounding/Ground fault circuit interrupters (GFCIs)

<b>11. Oxygen and Acetylene Equipment</b>	<b>12. Equipment</b>
Cylinder storage and maintenance Condition and maintenance of valves, regulators and gauges Condition and maintenance of hoses and fittings Pressures	Accidents related to moving parts of machinery Appreciation of principles of guarding Importance of regular maintenance
<b>13. Transportation</b>	<b>14. Excavations</b>
Transport to and from site Hazard connected with site transport Competent drivers Dumpers Tipping trucks Movement near excavations	Method of shoring Precautions while shoring Precautions at edge of excavations Removal of shoring Sheet steel piling
<b>15. Working platforms, Ladders and Scaffolding</b>	<b>16. Cranes and other Lifting Machines</b>
Hazards connected with the use of ladders Maintenance and inspection Type of scaffold Overloading Work on roofs Fragile material	Licensing, certification and training required for operation of cranes Slinging methods Signalling Access to crane(s) Maintenance and examination Ground conditions
Openings in walls and floors Use of safety belts and nets	Hazards and accident prevention methods connected with the use of different types of cranes/heavy equipment Crane Lift Plan for all lifts
<b>17. Lifting Tackle</b>	<b>18. Fire Prevention and Control</b>
Slings - single and multi-legged Safe working loads (SWLs) Safety hooks and eyebolts Cause of failure Maintenance and examination	Principle causes determining fire Understanding fire chemistry Fire fighting equipment Fire fighting training
<b>19. Communications</b>	
Effective methods of communication (particular interest to non-English speaking workers) Method and preparation of reports Safety committees Safety meeting	

<b>DFCCIL</b>
<b>General Instruction : DFCCIL/SHE/GI/008</b>

**DAYS TO BE OBSERVED FOR CREATING SHE AWARENESS**

1 <sup>st</sup> Monday to Sunday of January	Road Safety Week (Subjected to confirmation from Ministry of Road Transport, Govt. of India every year.)
16 <sup>th</sup> February	Kyoto Protocol Day
March	Red Cross Month
1 <sup>st</sup> to 7 <sup>th</sup> May	Emergency Preparedness Week
4 <sup>th</sup> March	National Safety Day
7 <sup>th</sup> April	World Health Day
14 <sup>th</sup> April	Fire Safety Day
18 <sup>th</sup> to 22 <sup>nd</sup> April	Earth Week
20 <sup>th</sup> April	Earth Day
20 <sup>th</sup> April	Noise Awareness Day
28 <sup>th</sup> April	ILO World Day for Safety and Health at Work Day
5 <sup>th</sup> June	World Environmental Day
12 <sup>th</sup> June	World Day against Child Labours
9 <sup>th</sup> July	Occupational Health Day
17 <sup>th</sup> October	World Trauma Day
1 <sup>st</sup> December	World AIDS Day

<b>DFCCIL</b>
<b>General Instruction: DFCCIL/SHE/GI/009</b>

**Minimum Requirements of SHE Communication Posters / Signages / Video**

- For the purpose of Minimum requirements of SHE Communication Posters / Signages / Video the contracts are categorized into the following groPSS:

<b>Contract Value (Initial awarded value of contract)</b>	<b>Group</b>
Up to Rs. 25 Cr.	A
Up to Rs. 100 Cr.	B
Up to Rs. 250 Cr.	C
More than Rs. 250 Cr.	D

- Every contractor falling into the above groPSS shall prepare a SHE Communication Plan as a part of site specific SHE Plan and shall include the following minimum requirement of Posters / Signages / Video as applicable. In case readymade posters are available in any of the category from National Safety Council or any other safety related organisations they may procure the same and display it. In case the same is not available then the Contractors' shall make necessary arrangements to get the posters designed and printed on their own. All posters shall each be in Hindi, English and the regional language.

All the above are to be detailed in the Contractor's Site Specific SHE Plan and he shall obtain the Engineer's prior consent for the numbers, contents, locations, etc.

Table No.: 1 - Minimum No. of Posters

<b>Sl. No</b>	<b>SHE Poster Title</b>	<b>Minimum No. of concepts in each title</b>	<b>No. of Posters / Signage / Video</b>			
			<b>Group A Contract</b>	<b>Group B Contract</b>	<b>Group C Contract</b>	<b>Group D Contract</b>
1.	Safety Culture	5	Each 10	Each 50	Each 75	Each 100
2.	Daily Safety Oath	1English, 1 Hindi & 1 in regional language	Each 100	Each 200	Each 500	Each 1000

3.	Mandatory PPE Usage					
a)	Signages to display the messages like PPE ZONE, NO PPE ZONE, HARD HAT AREA etc.	2 types of sizes made up of metal sheet to be mounted at different locations	Each 25	Each 50	Each 75	Each 200
b)	Helmet	5	Each 25	Each 50	Each 75	Each 200
c)	Shoe	5	Each 25	Each 50	Each 75	Each 200
d)	Goggles & Ear Protection	5	Each 25	Each 50	Each 75	Each 200
e)	Full Body Harness	5	Each 25	Each 50	Each 75	Each 200
f)	Hi-Vi Jacket	5	Each 25	Each 50	Each 75	Each 200
4.	Emergency Management Plan	5	Each 25	Each 50	Each 75	Each 200
5.	Working at Heights	10	Each 25	Each 50	Each 75	Each 200
a)	Ladder, Stairway, Scaffold - Signages to display the messages like SAFE, UNSAFE, FIT FOR USE, AVOID USE etc.	5 types of sizes made up of metal sheet to be mounted at different locations	Each 25	Each 50	Each 75	Each 200
6.	Site Electricity	5	Each 25	Each 50	Each 75	Each 200
7.	Crane Safety	5	Each 25	Each 50	Each 75	Each 200
8.	Slings	5	Each 25	Each 50	Each 75	Each 200
9.	Rigging Procedures	5	Each 25	Each 50	Each 75	Each 200
10.	Excavation	5	Each 25	Each 50	Each 75	Each 200
11.	Occupational Health (Mosquito Control, HIV/AIDS awareness, Dust Control, Noise Control, No Smoking/Spitting, etc.)	10	Each 25	Each 50	Each 75	Each 200
12.	First – Aid	3	Each 25	Each 50	Each 75	Each 200



13.	Labour Welfare Measures (Payment of Minimum Wages, Avoidance of Child labour, Signing in the Muster Roll, In case of accidents-what to do? Etc	5	Each 25	Each 50	Each 75	Each 200
14.	Importance of "Safety Handbook"	1	25	50	75	200
15.	Traffic Safety (Speed limit, safe crossing and working within barricaded area etc.)	5	Each 25	Each 50	Each 75	Each 200
16.	Environmental Monitoring (Spillage of Muck, hazardous material, Improper drainage, water spray for dust containment etc.)	5	Each 25	Each 50	Each 75	Each 200
17.	Video in Hindi on PPE usage – 15 minutes duration	1	-	-	-	1

**Note 1:** Items mentioned under 17 is video. Items under 3 (a) and 5 (a) are metal signage boards and all other items are posters.

**Note 2:** The above minimum numbers are for guidance only. The actual number will depend on the project's specific requirements. The Contractor shall propose and obtain Engineer's prior consent to the final numbers, locations, etc.

Table No.: 2 – Size of Posters / Signages

<b>Sl. No</b>	<b>Item</b>	<b>Size</b>
1.	Posters – Standard	17"x22" –135 GSM 4 Colour Printing
2.	Posters – Special (Wherever required)	17"x22" card laminated FA Poster
3.	Posters - Mega size (Wherever required)	32"x40" Flex FA Poster
4.	First-Aid Booklet	6"x4"
5.	Safety Handbook	6"x4"
6.	Signages	Small : 12"x6" Big : 24"x12"
7.	Road Traffic Sign Boards	Strictly as per Indian Road Congress (IRC) specifications

Table No.: 3 – Safety Signage Colour (as per IS: 9457)

<b>Sl. No</b>	<b>Type of signage</b>	<b>Colour</b>
1	Mandatory	Blue
2	Danger	Yellow
3	Prohibitory	Red
4	Safe conditions	Green

<b>DFCCIL</b>
<b>General Instruction : DFCCIL/SHE/GI/010</b>

**Experts / Agencies for SHE Services**

Sl. No.	Organisation	Services
1.	Bureau Veritas India Pvt. Ltd.,	<ul style="list-style-type: none"> <li>• SHE Management / Technical Training</li> </ul>
2.	BSI Management Systems The Mira Corporate Suites (A-2) Plot No.: 1 & 2, Ishwar Nagar Mathura Road New Delhi – 110 020 Phone : 011-2692 9000 Fax. : 011 – 2692 9001 E-mail: rajk.prasad@bsi-global.com	<ul style="list-style-type: none"> <li>• SHE Management / Technical Training</li> </ul>
3.	Central Labour Institute	<ul style="list-style-type: none"> <li>• SHE Management / Technical Training</li> </ul>
4.	Construction Industry Development Council 801, 8 <sup>th</sup> Floor, Hemkunt Chambers, 89, Nehru Place, New Delhi – 110 019	<ul style="list-style-type: none"> <li>• SHE Management / Technical Training</li> </ul>
5.	Det Norske Veritas AS,	<ul style="list-style-type: none"> <li>• SHE Management / Technical Training</li> </ul>
6.	DuPont Safety Resources, E.I. DuPont India Private Limited, Arihant Nitco Park 6 <sup>th</sup> Floor, 90, Dr. Radhakrishnan Salai, Mylapore, Chennai-600 004 Phone: 044-2847 2800, 2847 3752 Fax: 044-2847 3800 Mobile: 9381201040 Website: in.dupont.com	<ul style="list-style-type: none"> <li>• SHE Management Training</li> </ul>
7.	EQMS INDIA PVT. LTD. E-49, 1 <sup>st</sup> Floor, Dazzle House, Jawahar Park, Main Vikas Marg, Laxmi Nagar, Delhi-110 092 Phone: 91-11-220 17639/2204 4754 Fax: 91-91 2201 5150	<ul style="list-style-type: none"> <li>• ISO Certification</li> <li>• SHE Management / Technical Training</li> </ul>

	E-mail: eqms@eqmsindia.org Website: www.eqmsindia.com	
8.	Green Cross Consultants 59, 7 <sup>th</sup> Cross, 1 <sup>st</sup> Floor, Jai Bharath Nagar, Banglore-560 033 Phone: 080-2549 6782 E-mail: etgrangan@yahoo.com	<ul style="list-style-type: none"> <li>• SHE Management / Technical Training</li> </ul>
9.	Pentasafe Academy,	<ul style="list-style-type: none"> <li>• SHE Management / Technical Training</li> <li>• SHE Practical Field Training for Height Safety</li> </ul>
10.	International Engineering Company K – 10, South Extension, Part – 2, New Delhi – 110 049 Phone: 011 – 26254761, 26258130 Mobile: 9312260130 E-mail: ashok@intenco.net	<ul style="list-style-type: none"> <li>• Crane and Lifting appliances and Gears Certification</li> <li>• SHE Practical Field Training for Crane Safety</li> </ul>
11.	L & T Eutectic 32, Sivaji Marg New Delhi – 110 015 Phone: 011 - 51419538, 51419539 Fax: 011 - 51419600 Website: www.Inteutecticwelding.com	<ul style="list-style-type: none"> <li>• SHE Practical Field Training for Welding Safety</li> </ul>
12.	MFA Crucial Moments Healthcare Pvt. Ltd., 42, Okhla Industrial Estate, Phase – II New Delhi – 110 020 Phone: 011 – 55624000 Fax: 011 – 55624010 E-mail: contact@crucialmoments.net	<ul style="list-style-type: none"> <li>• First-aid Training</li> </ul>
13.	Modicare Foundation 4 Community Centre, New Friends Colony, New Delhi – 110 065 Phone: 011 – 5167235059, Fax: 011 – 26915469 E-mail: <a href="mailto:nivedita@modi.com">nivedita@modi.com</a> , nivedita@gmail.com Hyderabad Add.: 107, Center Point Andheri Kurla Road, JB Nagar andheri (E) Hyderabad – 400 059, Mob.: +91 98205 78021	<ul style="list-style-type: none"> <li>• HIV / AIDS awareness training</li> </ul>
14.	National Productivity Council	<ul style="list-style-type: none"> <li>• SHE Management / Technical Training</li> </ul>
15.	National Safety Council	<ul style="list-style-type: none"> <li>• SHE Management / Technical Training</li> </ul>

16.	NICMAR (National Institute of Construction Management and Research) 910,9 <sup>th</sup> Floor, Hemkunt Chambers, 89, Nehru Place, New Delhi – 110 019 Phone: 011 – 51618415, 51618417, 51618418 Fax: 011 – 51618416	<ul style="list-style-type: none"> <li>• SHE Management / Technical Training</li> </ul>
17.	Quality Growth Services Pvt. Ltd. H-13, Kirti Nagar, New Delhi – 110 015 Fax: 011 – 25431737 / 25438598 / 25918332 E-mail: qgs@qgspl.com Website: www.qgspl.com	<ul style="list-style-type: none"> <li>• ISO Certification</li> </ul>
18.	Safety Engineers Association (India) Flat No.:12, Block No.: 3 Mansarovar Apartments 11 / A Arcot Road Porur, Chennai – 600 116 Phone: 044 – 2476 8697 E-mail: seaindia@yahoo.com	<ul style="list-style-type: none"> <li>• SHE Management / Technical Training</li> </ul>
19.	SGS India Private Limited	<ul style="list-style-type: none"> <li>• SHE Management / Technical Training</li> </ul>
20.	SHE Management Consultancy & Support Services, 145 A, Pocket-VI, (DDA Flats), Kondli Gharoli, Mayur Vihar-II, Delhi-110 096 Fax: 011-2262 5015 Mobile: 9811153873 E-mail: r_k_p@vsnl.net	<ul style="list-style-type: none"> <li>• SHE Management / Technical Training</li> </ul>
21.	St. Johns' Ambulance Red Cross Road New Delhi – 110 001	<ul style="list-style-type: none"> <li>• First-aid Training</li> </ul>
22.	TUV SUD South Asia	<ul style="list-style-type: none"> <li>• SHE Management / Technical Training</li> </ul>
23.	Western India Automobile Association	<ul style="list-style-type: none"> <li>• SHE Practical Field Training on Defensive Driving</li> </ul>
24.	Welding Research Institute Bharat Heavy Electricals Ltd. (BHEL) Trichirappalli, Tamil Nadu – 620 014 Phone: 0431 – 2577029, 2577283 Fax: 0431 – 2520770 E-mail: wri@bheltry.co.in	<ul style="list-style-type: none"> <li>• SHE Practical Field Training for Welding Safety</li> </ul>

<b>DFCCIL</b>
<b>General Instruction: DFCCIL/SHE/GI/011</b>

**MINIMUM LIGHTING REQUIREMENTS**

S. No.	Facility or Function	Luminance – lx (lm/ft <sup>2</sup> )
1.	Administrative areas (offices, drafting and meeting rooms, etc.)	540 (50)
2.	Construction areas <ul style="list-style-type: none"> <li>- general indoor</li> <li>- general outdoor</li> <li>- tunnel and general underground work areas (minimum 110 lux required at tunnel and shaft heading during drilling, mucking and scaling)</li> </ul>	55 (5) 33 (3) 55 (5)
3.	Access ways <ul style="list-style-type: none"> <li>- exit ways, walkways, ladders, stairs</li> </ul>	110 (10)
4.	Maintenance / Operating areas / shops <ul style="list-style-type: none"> <li>- vehicle maintenance shop</li> <li>- carpentry shop</li> <li>- outdoors field maintenance area</li> <li>- refueling area, outdoors</li> <li>- shops, fine details work</li> <li>- shops, medium detail work</li> <li>- welding shop</li> </ul>	325 (30) 110 (10) 55 (5) 55 (5) 540 (50) 325 (30) 325 (30)
5.	Mechanical/electrical equipment rooms	110 (10)
6.	Hoists, Elevators, freight and passenger	215 (20)
7.	Warehouses and storage rooms/area <ul style="list-style-type: none"> <li>- indoor stockroom, active/bulk storage</li> <li>- indoor rack storage</li> <li>- outdoor storage</li> </ul>	110 (10) 270 (25) 33 (3)
8.	Health Centres and First aid stations and infirmaries	325 (30)
9.	Toilets, wash and dressing rooms	110 (10)
10.	Work areas – general (not listed above)	325 (30)
11.	Parking areas	33 (3)
12.	Visitor areas	215 (20)
13.	Laboratories	540 (50)

<b>DFCCIL</b>
<b>FORM No. : SF/001</b>

<b>FORMATION OF PROJECT SHE COMMITTEE</b>	
<b>Contract No.</b>	
<b>Contractor Name</b>	
<b>Contract Title</b>	

<b><u>CIRCULAR</u></b>
<p><b><u>Committee</u></b>                  The following SHE Committee is constituted with immediate effect:                  Chairman:                  Members:                      1)                      2)                      3)                      4)                      5)                  Secretary</p>
<p><b><u>Periodicity</u></b>   <b><u>The committee will meet at least once in a month on the day (specify date)</u></b></p>
<p><b><u>Agenda</u></b>  <b><u>Secretary will circulate agenda of the meeting at least seven days in advance of the schedule date of the meeting.</u></b></p>
<p><b><u>Circulation</u></b>  <b><u>Gist of the meeting will be minuted in the standard format and circulated to the following under the signature of the secretary</u></b>  <b><u>1. Chairman</u></b>  <b><u>2. DFCCIL Representatives</u></b>  <b><u>3. Members</u></b>  <b><u>4. Others concerned</u></b></p>
<p><b><u>Date:      Signed By:-----</u></b>  <b><u>CHAIRMAN</u></b></p>

<b>DFCCIL</b>
<b>Form No.: SF/002</b>

<b>MINUTES OF SAFETY MEETING</b>			
Contract No.:			
Contractor Name			
Contract Title			
Meeting No.		Date of Meeting	
Location of meeting			

MEMBERS PRESENT	INVITEES	MEMBERS ABSENT

<b>REPORT SENT TO</b>					
No. of Copies	Name / Dept.	No. of Copies	Name / Dept.	No. of Copies	Name / Dept.

Prepared By:	Location:	Date:
--------------	-----------	-------



**MINUTES OF SAFETY MEETING**

<b>Item No.</b>	<b>Description of Discussion</b>	<b>Action By</b>	<b>Target</b>	<b>Remarks</b>
1	Complaints received from Engineer / Employer and corrective and preventive action			
2	Review of MOM of previous meeting			
3	DFCCIL's / Observation from third party			
4	First - Aid cases / Reportable accident cases			
5	Future jobs and specific requirement			
6	Status of implementation of Safety plan			
7	Sub-contractor performance			
8	Analysis of first-aid cases			
9	Need for any specific system / training / PPE's / resources			
10	Observation of safety committee during last walk down			

Next meeting is scheduled on:

Date :	Chief Accident Prevention Officer (Signature & Name)
Date :	Contractor's Representative (Signature & Name)

**\*\* End of Annexure 10 \*\***

Attachment: Addm 2-1

Annexure 11: DFCCIL's procedure for Cross Acceptance

**PROCEDURE ORDER FOR CROSS ACCEPTANCE/APPROVAL OF SOFTWARE EMBEDDED ELECTRONICS SYSTEMS AND NEW/IMPORTED TECHNOLOGY PRODUCTS FOR RAILWAY SIGNALLING FOR DFCCIL**

**I. Preface**

- (a) These guidelines are meant for evaluating software embedded electronic systems and new/imported technology products for Railway signaling, which are already in use on a passenger carrying service anywhere in the world at speed more than 100KMPH, for adoption on DFCCIL using the concept of cross acceptance/cross approval. The procedure outlined in relevant CENELEC or any other equivalent standards to define and verify the safety requirements form the basis of these guidelines.
- (b) These guidelines are applicable for evaluation of equipment against valid Contract Agreement with DFCCIL. These guidelines are to be applied as per requirement of respective Contract Agreement.
- (c) These guidelines do not absolve the Contractor of his overall responsibility towards the relevant contract(s) in any manner whatsoever.

**II. Object:**

The object of these guidelines is to outline the process, activities, responsibilities and documentation necessary to carry out the Cross Acceptance / Cross Approval exercise by DFCCIL.

**III. Responsibility of Safety Assurance:**

- (a) Safety clearance shall be given adopting the guidelines pertaining to Cross Acceptance/Cross Approval for adoption on DFC. This will include the System Hardware & Software Platform, Application software for implementing Safety Functions, Communication Interfaces, Input/Output modules, Power Supply (vital) Systems & other related equipment.
- (b) This approval for a particular product/system will be requested by the manufacturer of the system, through the Contractor. The manufacturer will be responsible for submission & authenticity of the documentation. The

documentation should be as per procedure laid down.

#### **IV. Applications:**

These guidelines shall be applied for evaluation & acceptance of all Software Embedded Electronic Safety Systems and New/Imported Technology Products for Railway Signalling for provision on DFC.

The Electronic systems/products are as under:

- (i) Electronic interlocking, Digital Axle Counters and Train Protection and Warning System
- (ii) STEP items to be supplied on account of STEP loan conditions

#### **V. Procedure:**

1. DFCCIL shall appoint an ISA for safety assessment of the equipment.
2. Contractor of the project shall ensure that manufacturer extends complete cooperation to DFCCIL/ISA/PMC.
3. Manufacturer shall depute his technical personnel for technical clarifications when required by DFCCIL/ISA/PMC.
4. The manufacturer/firm shall submit a Safety Plan to DFCCIL/ISA/PMC for evaluation of the system/equipment for Cross Acceptance/Approval. All documents shall be prepared in English language, checked & verified & marked appropriately indicating their version number, no. of alterations, etc.
5.
  - (a) Safety plan shall be prepared and submitted. This will include:-
    - (i) System description, which includes the system architecture /configuration, system design & safety principle adopted for hardware & software.
    - (ii) Safety Integrity Level of the system
    - (iii) Safety case
  - (b) Manufacturer shall check and verify that the system being offered meets the requirement of safety integrity laid down in the specifications.

- (c) Safety Case is documentary evidence that the safety system is conforming to and complies with the laid down safety requirements for it. Safety Case will have to be prepared in accordance with relevant CENELEC or equivalent standards & submitted to DFCCIL/ISA/PMC as the case may be for assessment. Safety case shall consist of the following documents:
- (i) Details of approval given by an authority responsible for clearing safety system for use on a passenger carrying service at speed of more than 100 KMPH anywhere in the world.
  - (ii) Standards to which the equipment have been developed and proposed to be supplied, i.e., CENELEC standard or any other equivalent standard adopted by that passenger-carrying Railway.
  - (iii) Details of agencies, which have done software/hardware validations.
  - (iv) Criteria adopted and assumption made.
  - (v) Documentation of these approvals, including trials, tests & measurements and simulation carried out.
  - (vi) Restrictions, precautions, conditions or limitations imposed while giving clearance and thereafter action taken by the manufacturer.
  - (vii) Calculations of Hazard rate or rate of unsafe side failure.
  - (viii) Details/documents related to installation, functional operation, maintenance & modifications. Part list, wiring diagram, cable requirement, and list of tools and measuring equipments along with specification shall be given.
  - (ix) Performance feedback duly authenticated and certified by various user Railways.

Name, Designation, Phone & FAX Nos. and address of the official certifying the performance feedback should be clearly available. This will include Mean Time Between Failures (MTBF) and Mean Time Between Wrong Side Failures (MTBWSF) and Mean Time To Repair (MTTR) figures as per format given in Annexure 'A'.

- (x) Software & related instructions to configure the system initially as well as later due to changes in yard layout.
- (xi) Complete history of development of the equipment shall be given.  
Modifications

carried out in the system, if any, during last five years shall be listed. Date of each modification with brief reasons for undertaking modification and whether modification has got approval

of original validation/approving agency. Version No. allotted after each modification shall be mentioned.

- (xii) Type test (if required), Routine tests (which must be carried out on each equipment by the manufacturer) and acceptance tests (which are to be carried out on the equipment in the firm's premises before delivery) formats with test procedures and its significance for safety/reliability assessment of equipment. Sample routine test report/type test report/factory acceptance test reports shall be submitted
  - (xiii) Details of climatic/EMI (Electro Magnetic Interference)/EMC (Electro Magnetic Compatibility) tests undergone by the equipment. Test reports of an accredited test laboratory (third party) shall be submitted. (The equipment shall also be subjected to environmental tests as per specification if not already done by some other reputed agency to the specified severity).
  - (xiv) Clause wise compliance statement to the specification and
  - (xv) statement whether system is suitable for DFC application or will require modifications. Updated history of application has to be submitted in the format as per Annexure 'B' for use in passenger carrying service at speeds of more than 100 kmph.
6. The Safety Integrity Requirement/Level for all vital applications for LC gates, station & Block Signaling & Interlocking systems / equipment / Track Circuits to be used on DFC, shall be SIL-4. In case, any system is required to have a SIL other than Safety Integrity Level-4 (SIL-4), DFCCIL approval shall be obtained before evaluating the system for Cross Acceptance.
7. The evaluation for Cross Acceptance shall normally be in compliance to the relevant specifications.
8. Provenness criteria of equipment usage of same Type/Make & Model/Version shall be as under: -

Sl. No.	Category of Equipment/System	Minimum no. of Equipment	Equipment Hours in use
1.	Digital Axle Counter	50	4,32,000
2.	TPWS (i) On Board Equipment (ii) Track Equipment Balise	25 100	2,16,000 8,64,000

3.	Electronic Interlocking	25	2,16,000
4.	Other items	100	8,64,000

**Note 1:** For all the above items: At least 20% of the equipment/system, with a minimum of 10, should be in continuous operation for a minimum period of 720 days.

**Note 2:** If the offered equipment has undergone minor hardware/software upgradation to improve functionality/safety of the equipment in recent past, then the equipment utilisation of the earlier version (prior to minor modifications) can be considered for the provenness. This decision of considering the earlier version for provenness shall be taken by DFCCIL. However, in such cases, a minimum of 10 (Ten) upgraded equipments should be in continuous operation for a minimum period of 180 days. Field trial of the equipment shall be conducted as detailed at Annexure C.

**Note 3 :** STEP items to be supplied, as part of tied Japanese loan, if not deployed for commercial service anywhere, shall be subjected to type test and field trial as detailed at Annexure 'C'.

9. The manufacturer shall have adequate skilled and trained manpower with good expertise in relevant fields of manufacturing, installation, training, maintenance support etc. Details of these personnel with name, educational qualification, training undergone & experience shall be furnished at the time of approval.
10. Manufacturer seeking approval shall guarantee for supply of spares during life of the equipment & extend maintenance support.
11. The firm shall provide all necessary test facilities to DFCCIL representative in their premises in India and abroad as prescribed by their principals at the time of approval.
12. DFCCIL/ISA/PMC shall assess the safety case & prepare the assessment report clearly recommending whether the system/equipment is permitted for:-
  - a. Type test and trials
  - b. Field trials
  - c. Use on DFC
13. The type tests and field trials, as required, shall be conducted as per Annexure "C". After DFCCIL/ISA/PMC is satisfied with the documents submitted by the firm; results of the type test and field trial, if any; approval for the particular contract shall

be given.

14. If any document of safety case is withdrawn or if any problem with the product arises, the supplier shall inform DFCCIL immediately. In such or any similar case DFCCIL may modify/withdraw the approval, as required



**Annexure'A'**

**Format for Performance Feedback**

- 1. Name of System/Equipment :
- 2. Make :
- 3. Model/Version No. :
- 4. User Railway & Section :
- 5. Maximum Sectional Speed :
- 6. Arrange number of Trains per day :
- 7. Application of System/Equipment :
- 8. Problems faced and solutions evolved :
- 9. Failure data may be submitted as per format given below :

Location	No. of System / Eqpt.	Date of commissioning	Total hours in use	No. of safe side failures	No. of unsafe failures	MTBF	MTBWSF	MTTR
<b>Total</b>								

**Annexure'B'**

Format for history of Application

SI NO	Hardware version No.	Software version No.	Model No.	User Rly.	Station/ Section	No. of Eqpts. In use	In use from date

## **Annexure 'C'**

### **Type test for signalling items**

In case DFCCIL is fully satisfied with the consolidated report of the assessment, approval shall be given for type testing of prototype sample.

1. The type testing of prototype sample shall be undertaken to the satisfaction of DFCCIL.
2. Type tests shall be carried out on specific items to ensure that they perform their intended functions when subjected to all permutations and combinations of external environment and other factors.
3. The following tests shall constitute type tests :
  - (i) Visual inspection tests
  - (ii) Insulation resistance tests
  - (iii) Card level functional and fail safety tests
  - (iv) System level functional and fail safety tests
  - (v) Computerized testing
  - (vi) EMI/EMC tests
  - (vii) Environmental / Climatic Tests
  - (viii) System Diagnostic Tests
  - (ix) System Software Test
  - (x) Any other test deemed necessary
4. Manufacturer shall submit a comprehensive type test plan including procedure, type test format and expected results. The type test plan shall be finalized in consultation with DFCCIL / ISA / PMC.
5. Type tests shall be carried out at manufacturer's premises. Necessary testing equipments and competent man power shall be made available by the manufacturer.
6. Type test shall be carried out by DFCCIL representative / ISA.
7. Tests which cannot be carried out in house may be referred to independent test house of repute.
8. EMC / EMI tests may not be required if previous independent witness tests have

been successfully carried out and reported by document.

**Field trials for signalling items**

1. The field trials shall be conducted to the satisfaction of the DFCCIL.
2. The field trials shall be held on Indian Railways / DFC as decided by DFCCIL. DFCCIL shall coordinate with IR for this purpose.
3. The Contractor / Manufacturer shall make all arrangements for conducting field trials. This shall include; but not limited to; supply, installation, commissioning and monitoring of the equipment.
4. The trials shall be monitored in the following manner –

S N	Name of Division / Railway / Section	Name of station	Model and version no.	Date of installation	No. of failures*	Remarks

\* Analysis of cause of failures to be attached.

**Duration of field trial**

SN	Item / Equipment	Initial trial	
		Number of equipments	Duration
1.	EI	01	180 days in parallel and/or standalone mode or a combination thereof as decided by DFCCIL
2.	DAC	01	180 days in parallel and/or standalone mode or a combination thereof as decided by DFCCIL
3.	TPWS	One (01) set of on Board equipment and ten (10) sets of track side system shall be installed and detailed trials shall be conducted for 180 days for compliance to specifications and performance monitoring.	

**NOTE:**

1. The number of equipments and duration can be suitably revised, as required, by DFCCIL.
2. DFCCIL shall decide if field trials and type test can proceed simultaneously or not.

\*\*\*\* End of Annexure 11 \*\*\*\*

Attachment: Addm 2-2

Annexure 12: Cross acceptance responsibility matrix

S. No.	Activity	Contractor/ Supplier/ Manufacturer	DFC	PMC	ISA	Comments
1.	Appointment of ISA		✓			
2.	Submission of Safety case & other documents to ISA for Cross Approval	✓				Copy to DFC & PMC
3.	Preparation of assessment report based on safety case & documents				✓	
4.	Review of assessment report (Part 1)			✓		
5.	Review & approval of Assessment report (Part 1)		✓			
6.	Submission of type test plan	✓				
7.	Validation of type test plan				✓	
8.	Review of type test plan			✓		
9.	Approval of type test plan		✓			
10.	Conduct of Type tests	✓	✓	✓		
11.	Submission of Type Test Report	✓				
12.	Review & recommendation of Type Test Report				✓	
13.	Recommendation of Type Test Report			✓		
14.	Approval of type test report					
15.	Supply, Installation & commissioning of Field Trial Equipment	✓				
16.	Monitoring of Field Trial	✓	✓	✓	✓	
17.	Submission of Field Trial Report	✓				
18.	Submission of Final Safety Assessment report				✓	
19.	Review of Final Safety Assessment report			✓		
20.	Approval of Final Safety Assessment report		✓			
21.	Factory Acceptance Test of Cross Approved Equipment		✓	✓		

**NOTE:** The Employer/ Engineer/ ISA shall respond to each of the above submissions from the Contractor/Supplier/ Manufacturer at the earliest. However, in this respect the review period specified in FIDIC Clause 5.2 shall not apply.

**\*\*\*\* End of Annexure 12 \*\*\*\***